



Old Town Fairfax Historic Overlay District
STREETSCAPE STANDARDS



This page left blank intentionally.



INTRODUCTION

STREETSCAPE ZONES

STREET TYPES and GATEWAYS

STREETSCAPE ELEMENTS

APPENDIX

Credits and Acknowledgements

Mayor and City Council 2016-2018

Mayor David L. Meyer
Michael J. DeMarco
Jeffrey C. Greenfield*
Janice B. Miller
Jennifer E. Passey
Eleanor D. Schmidt*
Jon R. Stehle, Jr.

Mayor and City Council 2018-2020

Mayor David L. Meyer
Michael J. DeMarco
So P. Lim
Janice B. Miller
Jennifer E. Passey
Jon R. Stehle, Jr.
Sang H. Yi

Streetscape Standards Working Group

Downtown Property/Business Owner
Rick Dickson
Pete Federowicz
Lucas Druskin
Deborah Dillard
Eric Snyder

Community Appearance Committee

Kirk Holley
James Rich

Board of Architectural Review

Robert Kalmin

Historic Fairfax City, Inc.

Hildie Carney

City of Fairfax Staff

Bob Sisson, City Manager**
Robert A. Stalzer, City Manager
Brooke Hardin
Jason Sutphin
Supriya Chewle
Cathy Salgado
Christopher Bruno
David Summers
Wendy Block Sanford
Curt McCullough
Chloe Ritter

Project Consultant

Lardner/Klein Landscape Architects, P.C.
Daniel Consultants, Inc.
Kittelsohn & Associates, Inc.
Dominion Surveys, Inc.
Frazier Associates

*Term ended prior to City Council adoption.

**Retired prior to City Council adoption.

Table of Contents

INTRODUCTION

Purpose	1
Values	2
Welcoming	2
Sustainable	2
Adaptable	2
Accessible	2
Applicability	3
Historic Overlay District, City of Fairfax	3
Public Right-of-Way	4
Publicly Owned Properties	4
Coordination Required Between Agencies and Departments	5
Policy and Regulatory Framework for Right-of-Way Improvements	5
Phasing	7
Streetscape Components	7
Beyond the HOD	7
How to Use the Standards	8
Structure	8
Matching The Pieces	9
Using the Standards	9
Jurisdiction	10
Adopted Date	10

STREETSCAPE ZONES

Zone Definitions	12
Roadway Zone	12
Furnishings Zone	12
Pedestrian Zone	12
Gathering Zone	12

Zone Dimensions	13
Roadway Zone	13
Furnishings Zone	13
Pedestrian Zone	13
Gathering Zone	13
Dimensions Applicable to All Streetscape Zones	15
Zone Uses	16
Roadway Zone Uses	16
Furnishings Zone Uses	16
Pedestrian Zone Uses	16
Gathering Zone Uses	16

STREET TYPES AND GATEWAYS

Type Definitions	18
Active Street Type 1	19
Active Street Type 2	22
Active Street/Avenue Type 3	25
Gateways	28

STREETSCAPE ELEMENTS

Elements Definition	31
Division Matrix Sheet	31
Guidance Page	31
Specifications	31
Priority Between References	32
Furnishings	33
Division Matrix Sheet	33
Banner	35
Banner Pole - Cross Street	36
Bench	38

Table of Contents

Bicycle Rack	41	Plant List for Shrubs for use in Tree Pits, Bulb Outs, and Pots	103
Bollard/Barrier	44	Planting Guidance	104
Cycle Stall	47	Identifiers	105
Drinking Fountain	50	Division Matrix Sheet	105
Planter - Hanging Basket	52	Gateway - Major	106
Planter - Hayrack Basket	54	Gateway - Minor	107
Planter - Pot	56	Historic Markers	108
Trash Can	58	Public Art	109
Tree Grate	60	Wayfinding for Parking and Pedestrians	110
Lighting	63	HOD Parking Design Identification Signs and Pedestrian Wayfinding	111
Division Matrix Sheet	63		
Decorative Lighting	64		
Pedestrian Lighting	65		
Pavement	70		
Division Matrix Sheet	70		
Bulb Out	72		
Crosswalk - HOD - Impressed Preformed Thermoplastic on Asphalt Surface	74		
Crosswalk - HOD Main Street - Vehicular Brick Paver	76		
Crosswalk - HOD Main Street - Impressed Preformed Thermoplastic on Asphalt Surface	78		
Curb Ramp - Brick	80		
Intersection - HOD Main Street Vehicular Brick Paver	84		
Intersection - HOD Main Street Impressed Preformed Thermoplastic on Asphalt Surface	86		
Loading Zone/Parking Space Markings - HOD Main Street Vehicular Brick Paver	88		
Loading Zone/ Parking Space Markings - HOD Main Street Impressed Preformed Thermoplastic on Asphalt Surface	90		
Plants	92		
Division Matrix Sheet	92		
Tree Pit - Linear Pit	94		
Tree Pit - Soil Cells	96		
Tree Pit - Structural Soil	98		
Plant List for Groundcovers for use in Tree Pits, Bulb Outs, and Pots	100		
Plant List for Hanging Basket/Hayrack Basket	101		
Plant List for Planter Pot	102		

APPENDIX

Abbreviations and Acronyms	APP-1
References and Definitions	APP-1



INTRODUCTION



Introduction

PURPOSE

The Old Town Fairfax Historic Overlay District Streetscape Standards is intended to guide preservation, aesthetic enhancement, and improvement of the City of Fairfax's historic core and its public right-of-ways. These standards focus on the Old Town Fairfax Historic Overlay District (HOD) and provide a comprehensive and coordinated set of elements for incorporation on the City's public right-of-way in its historic core.

Where applicable, the City may choose to apply the Streetscape Standards beyond the HOD boundaries, extending the standards to both sides of a street when the HOD boundary falls on a street, to areas outside of the public right-of-way that serve as a public sidewalk, and to areas within the Transition Overlay District (TOD) where appropriate.

The Streetscape Standards serve as a companion document to the City's Public Facilities Manual (PFM), the City of Fairfax's Design Guidelines, the Virginia Department of Transportation (VDOT) Standard Details, and the Manual on Uniform Traffic Control Devices (MUTCD), Virginia Supplement. Details and standards from these companion documents are not duplicated in the Streetscape Standards. Instead, reference to the appropriate source is made for any streetscape element in the section on Elements.

Consistent application of the Streetscape Standards to the City's HOD's public right-of-way will achieve the following outcomes.

- Creation of a cohesive, user-friendly, and visually appealing downtown streetscape
- Enhancement of the preservation and vitality of the City's Historic District and HOD
- Longevity of improvements through the use of high quality, long-lasting materials
- Stewardship through the use of sustainable and environmentally friendly materials and methods

The Streetscape Standards will be used by City of Fairfax staff internally and to guide private investment within the public right-of-way.

Looking west on Main Street towards University Drive in the heart of the City's HOD



Introduction

VALUES

The streetscape elements selected for inclusion in the Streetscape Standards reflect the values voiced by the community and their vision for the City's downtown core and HOD.

WELCOMING

Most important, the Streetscape Standards have been developed to make the HOD more welcoming and attractive. By creating welcoming gateways and a lively streetscape, the hope is to attract more people downtown to work, play, and live.

SUSTAINABLE

The recommended Streetscape Standards recognize the importance of an environment that minimizes water and energy use, enhances bicycle and pedestrian use, supports transit service, increases tree canopy and stormwater infiltration, and reduces and recycles waste.

The use of high quality materials is recommended to ensure that the streetscape improvements are durable and will age well over time. High quality, low maintenance elements will support the long-term preservation of capital investments in the HOD and enhance the sense of a welcoming and coherent public environment.

ADAPTABLE

The HOD is composed of a variety of street and right-of-way conditions. This complexity is recognized by the Streetscape Standards and the identification of sub-types of Active Streets, as defined in the City of Fairfax 2035 Comprehensive Plan, Chapter 3: Multimodal Transportation.

ACCESSIBLE

The Streetscape Standards comply with the United States Access Board ADA Accessibility Guidelines (ADAAG), 2010 Standards for Accessible Design and follow as best practice content within the Accessibility Guidelines for Pedestrian Facilities in the Public Right-of-Way (PROWAG) for any subject that is not fully covered by ADAAG.

Downtown Fairfax

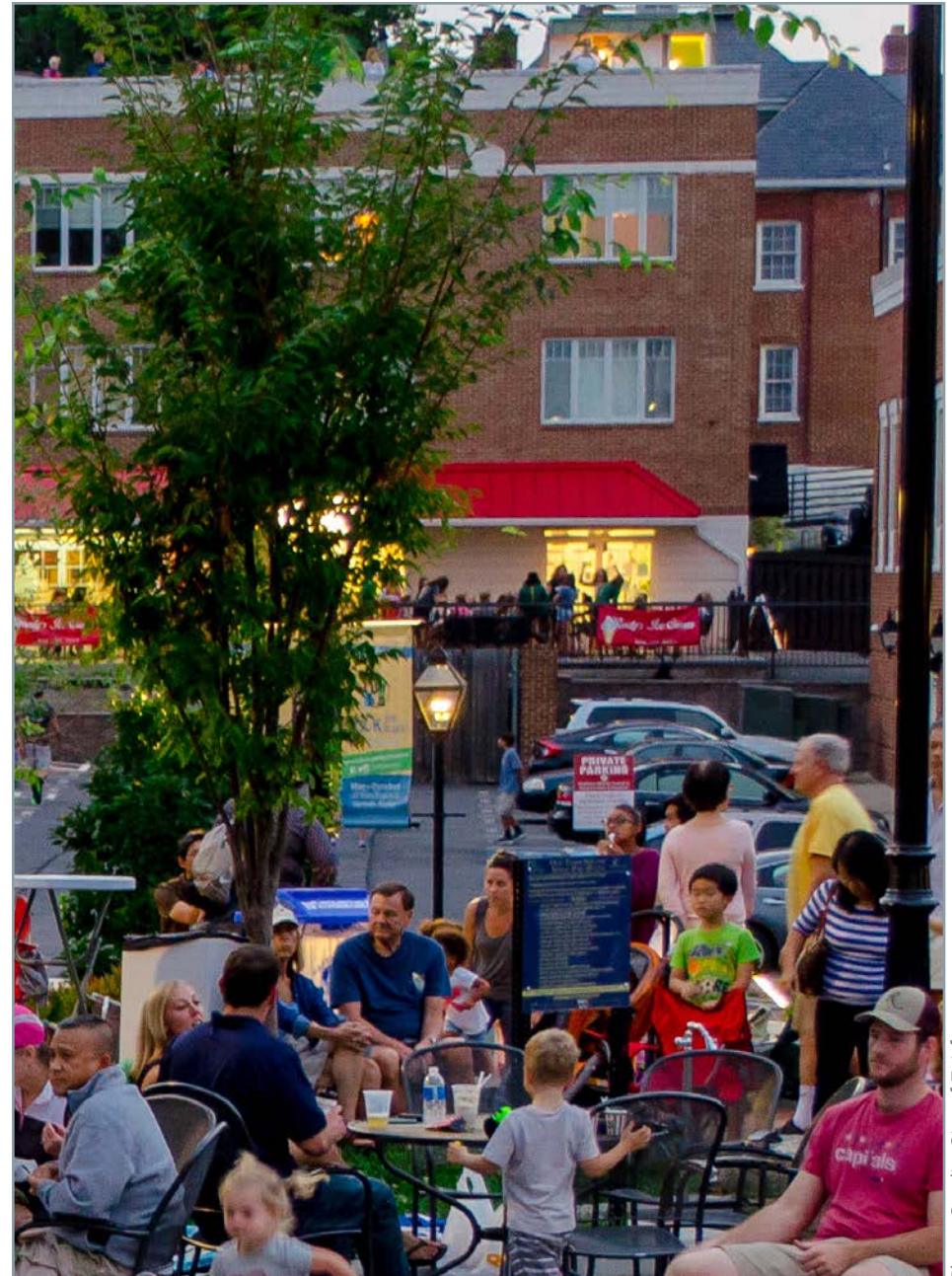

Photo Credit: City of Fairfax

Introduction

APPLICABILITY

HISTORIC OVERLAY DISTRICT, CITY OF FAIRFAX

The City of Fairfax was originally established as the Town of Providence in 1805. The settlement grew around the County Courthouse within what is now known as Old Town Fairfax. A seven block area was designated the City's Old and Historic District in 1964 in an effort to preserve and protect the historic area, with adjacent properties being added over the years.

The majority of the City's Old and Historic District was officially listed on the Virginia Landmarks Register (VLR) in 1986 and on the National Register of Historic Places (NRHP) in 1987. The City of Fairfax Historic District is an area encompassing the Fairfax County Courthouse and the supporting buildings constructed for office and retail functions on major transportation routes adjacent to the courthouse lot.¹

The contributing buildings represent each period of historical development of the town from 1800 - 1930s. The historic district is a mixture of building age and materials, while most elements conform to the use of brick or wood materials, a two-story height and a Main Street scale and decidedly vernacular scale.² The spatial pattern of lots and streets is one primarily of long and narrow lots, with buildings located close to the street on or near the front property line.³

The moniker of Old and Historic District was changed to the Old Town Fairfax Historic District in 1990.⁴ Incorporated within the City's Zoning Code (ZO) as an Historic Overlay District (HOD), this designation is the primary tool available for the local regulatory protection of historic properties. The overlay district provides a vehicle for the City to impose special bulk, area and use restrictions and design controls on structures and sites. Within these districts, all proposed alterations, demolitions and new construction must be reviewed and approved by the City's Board of Architectural Review (BAR).⁵

The HOD encompasses an area that includes segments of Old Lee Highway, University Drive, Chain Bridge Road, West Street, Main Street, Sager Avenue,

- 1 United States Department of the Interior, National Parks Service. *National Register of Historic Places Inventory--Nomination Form*, 1987. 8. Significance.
- 2 Ibid. Summary Description
- 3 Ibid.
- 4 The City of Fairfax, Virginia. *Design Guidelines: The Old Town Fairfax Historic and Transition Districts*, 1993. <http://www.fairfaxva.gov/home/showdocument?id=1718>
- 5 City of Fairfax Comprehensive Plan, Historic Resources. April 2012. Page 111.

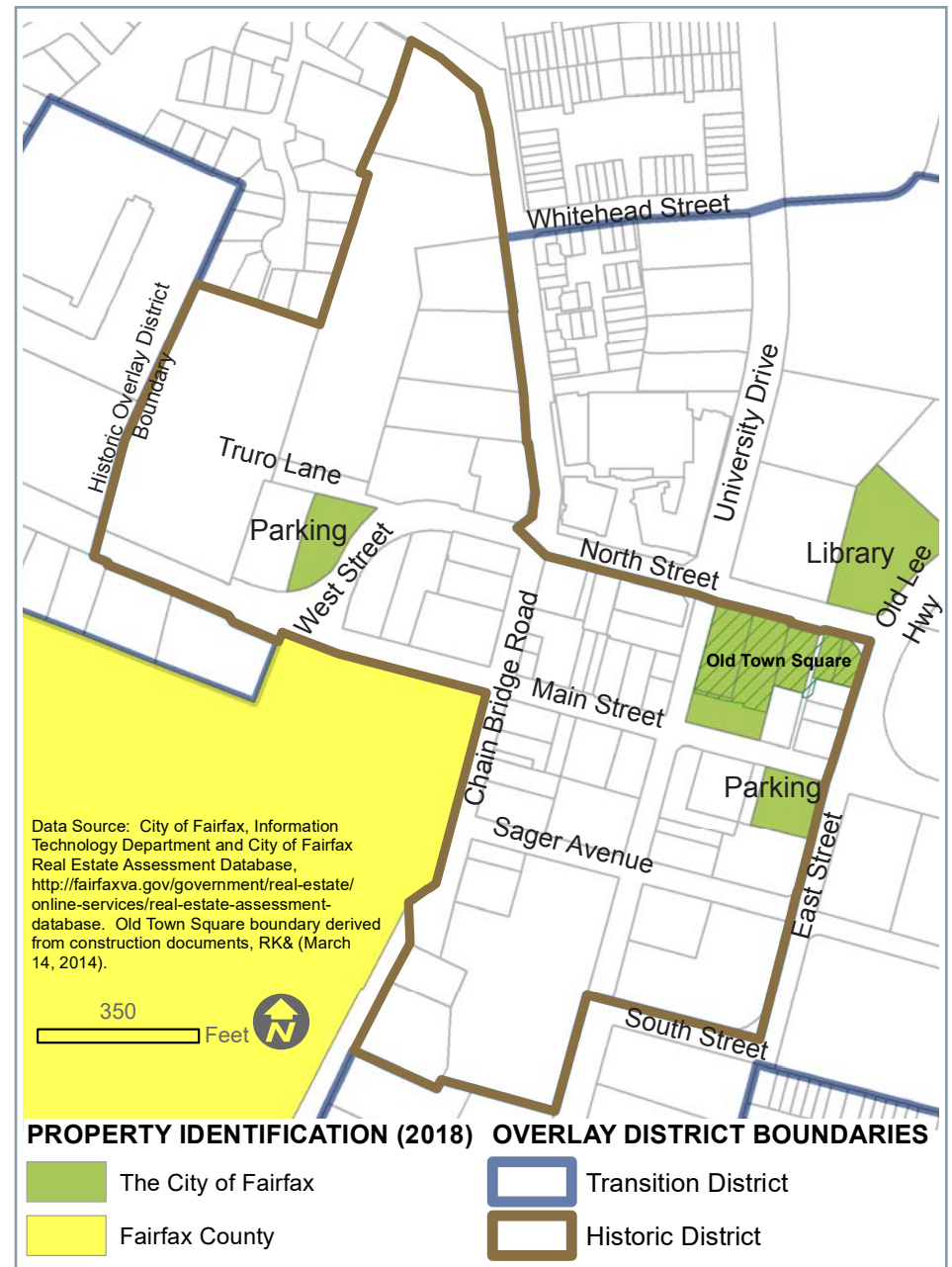

Introduction

and South Street. The City of Fairfax HOD includes much of the National Register Historic District as well as additional buildings and structures of local historic significance.

PUBLIC RIGHT-OF-WAY

The Streetscape Standards focus on enhancements to the public right-of-way, which includes roads, streets, easements, and sidewalks. A form of public open space, public rights-of-way support pedestrian and vehicular mobility and connectivity, create view corridors, and offer opportunities for additional green space, pedestrian enhancements, transit improvements, and bicycle accommodations. The HOD's character, function, and appearance and the community's health, safety, and welfare are significantly impacted by the design of the public right-of-way.

The public right-of-way within and adjacent to the HOD ranges from 50 feet to 85 feet wide, and accommodates two to five traffic and turn lanes, on-street parking lanes, public sidewalks, and landscaped areas. In some areas, buildings directly abut the right-of-way, while in others, the building is offset from the right-of-way by as much as 75 feet.

Most of the perceived public sidewalk is located within the right-of-way within the HOD. However, due to its historic building pattern, there are places within the HOD where the public uses private property as a public sidewalk. Where the right-of-way is particularly narrow, tools such as an easement or other agreement between the City and a private property owner may create the opportunity to extend streetscape improvements to provide a publicly accessible sidewalk.

PUBLICLY OWNED PROPERTIES

Within and immediately adjacent to the HOD are properties owned by the public, separate from the public right-of-way. These include Old Town Square (City) and the County Courthouse Complex. Although publicly owned, the Streetscape Standards do not apply to these properties, guidance for the sites within the City of Fairfax is provided in the *City of Fairfax Design Guidelines*, adopted in 2018.



Looking west on Main Street towards Chain Bridge Road, this block of Main Street has narrow sidewalks and little space for the addition of streetscape elements

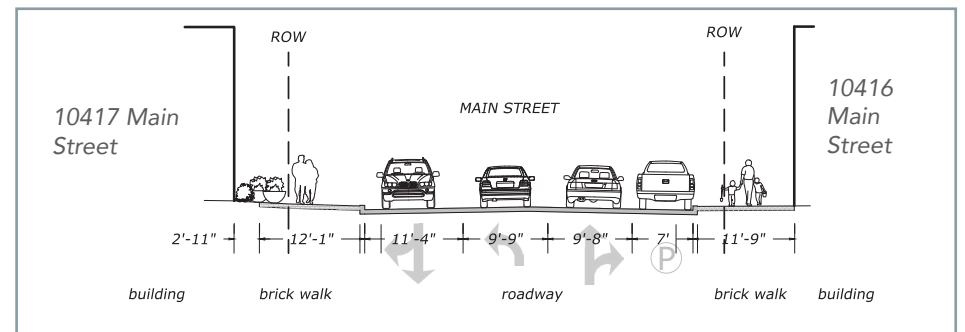

Typical cross-section of existing conditions on Main Street, between Chain Bridge Road and University Drive, illustrating the narrow public right-of-way (ROW), sidewalk, and close proximity of buildings to the street

Introduction

COORDINATION REQUIRED BETWEEN AGENCIES AND DEPARTMENTS

The Streetscape Standards touch on different City of Fairfax departments and their responsibilities. Implementation of these standards must ensure that all departments as appropriate are coordinated.

Similarly, there a number of outside agencies and their work programs that must be coordinated with the implementation of the Streetscape Standards. Conflict between utility lines, utility boxes, traffic signal boxes, and equipment access with pedestrian activities is highly probable, given the limited amount of public right-of-way. These agencies include, but are not limited to Dominion Energy, Washington Gas, VDOT, and Fairfax Water.

POLICY AND REGULATORY FRAMEWORK FOR RIGHT-OF-WAY IMPROVEMENTS

The City's ordinances and adopted policy plans serve as the foundation for the Streetscape Standards. The City of Fairfax 2035 Comprehensive Plan Chapter 3: Multimodal Transportation defines the City's street typology which is used to further identify and define the street typology addressed within these standards. These standards are not a substitute for the City's Zoning Ordinance, adopted policy plans, or Public Facility Manual. Zoning regulations continue to apply in the HOD and are not repeated in the Standards.

The Streetscape Standards provide direction, guidance and specifications for implementation within the HOD of specific streetscape elements and construction details. If an element or construction detail is already addressed in another document, they are referenced in the standards but not duplicated.

A summary of some, but not all, regulatory and policy-oriented documents follow.

City of Fairfax Public Facilities Manual (PFM), partially updated January 2018 contains standard details and specifications for construction within the City of Fairfax. Standard details pertaining to the streetscape standards include but are not limited to the following: driveways, sidewalks, bikeways, sidewalks, bus shelter installation, street lighting, and planting details.

Looking north on University Drive at its intersection with Main Street in front of Old City Hall, a highly trafficked pedestrian location near Old Town Square



Introduction

City of Fairfax Zoning Ordinance (ZO), adopted July 2016 provides information on permitted uses and dimensional standards for residential districts, nonresidential districts, and overlay districts, including the HOD.

City of Fairfax 2035 Comprehensive Plan, adopted February 12, 2019 is the City's policy document that guides future land development.

Draft City of Fairfax Multimodal Transportation Plan (2017) identifies the transportation priorities for the City of Fairfax. The document defines a street typology for the City. Most of the City's HOD streets are Active Streets while a few are Avenues, Limited Connection Residential, or Neighborhood Circulator.

- Active Streets include few and narrow lanes, on-street parking, wide sidewalks, street trees, bike lanes, or sharrows
- Avenues carry moderate traffic volumes using one travel lane in each direction; some may have significant traffic volumes of traffic, with vehicles passing through to other local or area destinations
- Overall traffic volumes have remained steady since the year 2000
- The Old Town area is a Bus Transfer Improvement Area
- New street connections north and south of Main Street are recommended to break existing superblocks

City of Fairfax Design Guidelines, 2018 provides non-prescriptive guiding principles for private development within or within the viewshed of the City's three overlay zones - Historic Overlay District (HOD, Transition Overlay District (TOD), and Architectural Control Overlay District (ACOD). The guidelines, although focused on privately owned properties subject to the three overlay zones, contain a comprehensive plant materials list that is appropriate for use within the public right-of-way in the HOD.

Old Town Fairfax, Virginia Wayfinding Sign System, Sign Schedule & Map (Location Review 2015) outlines the various wayfinding signs to be placed in Old Town Fairfax and their proposed locations, as recommended in the Wayfinding Study prepared in 2008.

Virginia Department of Transportation (VDOT) Specifications and Details

ADAAG Public Rights-of-way provide guidelines and standards for streets and sidewalks and public rights-of-way for accessibility.

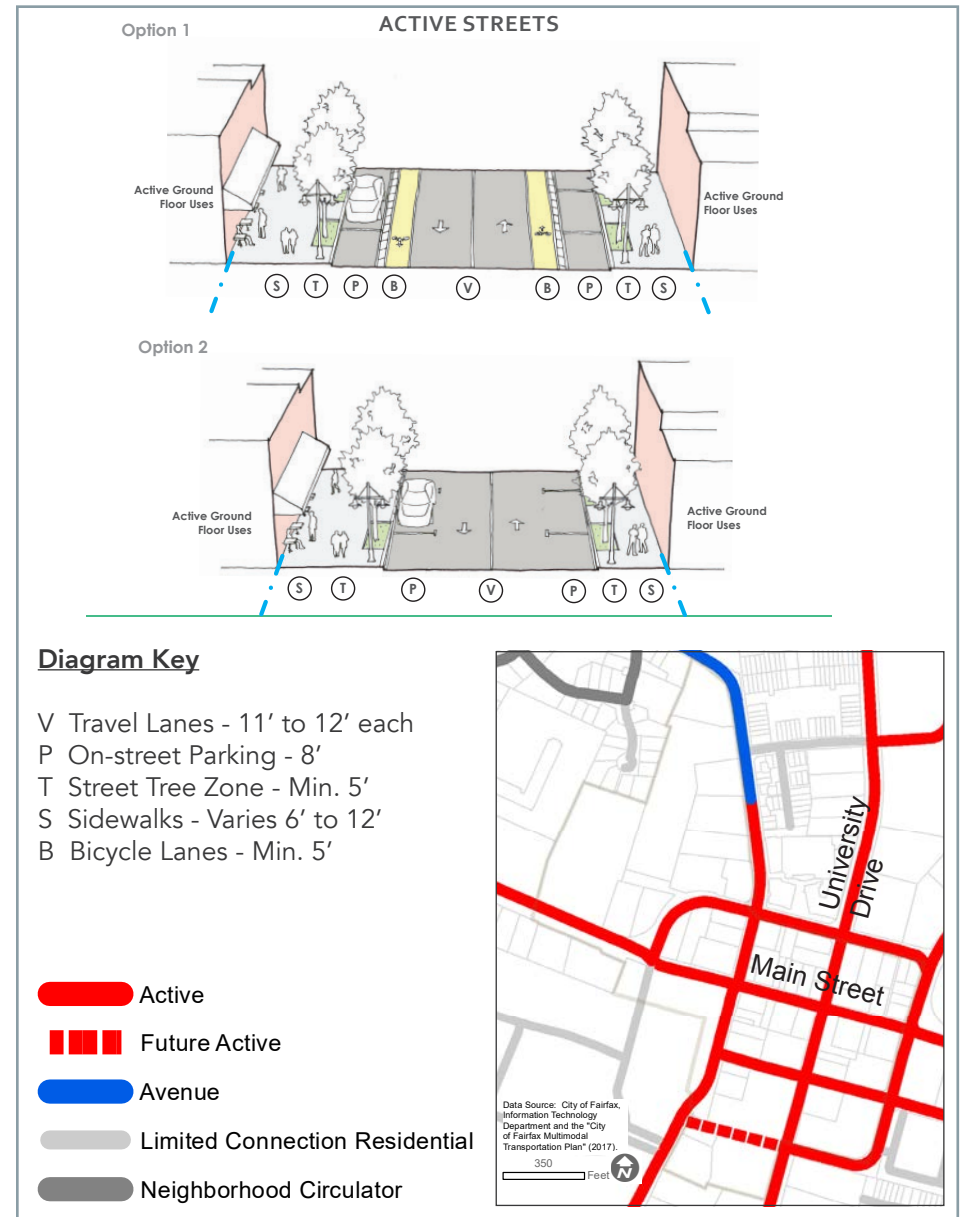

Draft City of Fairfax Multimodal Transportation Plan's excerpts: Active Street component diagrams at top and street designations within the HOD lower right

Introduction

PHASING

With guidance provided by the Streetscape Standards, an enhanced and improved public right-of-way will be created over time. Capital intensive, the installation of the streetscape improvements will be accomplished through multiple projects, with an array of funding sources. Given that the improvements will be pieced together, choreographing how each component is phased and coordinated is key to ensuring that the overall intent of the Streetscape Standards is achieved.

STREETSCAPE COMPONENTS

Pedestrian Lighting

The most complex installation of the Streetscape Standards within this document is the replacement of the existing pedestrian-scaled gas lighting with LED fixtures and new poles. The LED fixture referenced in this document may be procured directly from the vendor and installed and operated by the City or procured from Dominion Energy who will install and maintain the pedestrian street light under a lease agreement. Regardless of whether the City chooses to buy the fixtures and poles directly, or to enter into a long-term lease with Dominion, the LED fixtures will require new electrical service.

Replacing the 300-plus gas lights in and near the HOD will most likely be accomplished over a period of time. Based on funding available, if the City decides to purchase and install the lights independent of Dominion, it makes sense to program these improvements block by block, installing poles and fixtures on both sides of the street at one time.

The Round Lantern with either a 12 foot or 14 foot high mounting height and an approximate road width of 40 feet, spaced at 65'-70' on center in a staggered pattern across the street will meet the ANSI/IESNA RP-8-14 Roadway Lighting⁶ standards for pedestrian use. A final photometric should be run prior to installation to confirm spacing and location given the variety of impediments to street light placement such as driveways and utility vaults.

Curb Realignment and Drainage Adjustments

Utility relocations and curb realignments are the most complex and often most costly changes to make to the streetscape. Balancing the impact on business operations with the funds available will be critical in the determination of the extent of work. In some situations it will be less impactful on businesses to address

multiple blocks at one time, rather than tearing up the street and sidewalk block by block. Unlike installations in zones outside of the Roadway Zone, any activity involving, drainage, utilities, or curb realignments will also require temporary changes to current traffic patterns or possibly street closures.

Pedestrian Pavement

Most of the HOD is currently paved with brick pavers, per the direction of the City's PFM. Although some blocks may be converted to brick or new sidewalks built, most activity related to pavement will be for maintenance or redevelopment.

Site Furnishings

Outside of pedestrian lighting, furnishings such as benches, trash cans, bike racks, and planters are elements that may be added to the streetscape within the public right-of-way on a space available and need-based demand.

BEYOND THE HOD

These standards have been developed for application within the HOD. However, there are situations where applying those standards outside of the HOD boundaries is appropriate.

Pedestrian Lighting

The HOD-specified pedestrian lighting fixture and pole should not be extended to the TOD unless the HOD boundary falls mid-street. In that case, the HOD-specified pedestrian lighting fixture and pole may be located within the TOD as the City of Fairfax desires a common streetscape vocabulary on both sides of a specific street. The acorn light fixture currently found in some areas of the TOD is to be used throughout the TOD. Existing fixtures can be converted to LED.

Pedestrian Pavement

The sidewalks within the HOD are to be paved with brick pavers. Sidewalks within the TOD are to be concrete, unless the HOD boundary falls mid-street. To ensure a common vocabulary on both sides of a street, HOD specified pavers may be located within the TOD in this scenario.

Site Furnishings

The Streetscape Elements divisions for Furnishings and Plants are appropriate for use as well within the TOD's public right-of-way.

⁶ Illuminating Engineering Society of North America [IESNA]

Introduction

HOW TO USE THE STANDARDS

This document is designed to be an accessible resource, allowing the user to match a location to a street type and its associated streetscape zone and streetscape element. Intended to be a living document, it is structured to encourage the updating of streetscape elements as materials change and improve. The Standards are formatted to print one-sided in a landscape orientation.

STRUCTURE

The Streetscape Standards document is structured into four sections:

- Introduction
- Streetscape Zones
- Street Types and Gateways
- Streetscape Elements

The first section - **Introduction** - includes a summary description of the physical environment within the HOD's right-of-way and identifies applicable and related documents such as the City's Zoning Ordinance and Public Facilities Manual. This section also speaks to the values employed in the selection of specific elements, defines the public right-of-way, and introduces the framework developed to match the elements with the appropriate street type.

The second section - **Streetscape Zones** - introduces the spaces within the streetscape and their dimensions, regulatory requirements and guidance for placement of elements within each zone and uses that can be found or located within each zone.

The third section - **Street Types and Gateways** - provides detailed information on three street types and two gateway types within the HOD.

The fourth section - **Streetscape Elements** - houses the selected furnishings and materials for incorporation within the public right-of-way within the HOD. Keyed to street type and streetscape zone, this section provides both guidelines and where appropriate, specifications for elements such as pedestrian lighting and benches. If the streetscape element is already specified in another document such as the City of Fairfax Public Facilities Manual (PFM), the City of Fairfax Design Guidelines, or VDOT Standards, the reader is directed to that source to avoid duplication of materials.



Streetscape Standards sections

An **Appendix** follows and includes abbreviations and acronyms, and references and definitions.

Introduction

MATCHING THE PIECES

Matching the Street Type and Gateway with the Streetscape Zone provides the user with an applicable list of Streetscape Elements appropriate for a specific site. The three HOD street types are color-coded in green, blue and brown, and gateways in yellow and red, as illustrated in the diagram on the right.

The Street Type and Gateway is matched to the appropriate Streetscape Element, as indicated by the colored squares to the right. These squares indicate the applicability of the specific element to a street or gateway type:

- Bench as pictured is applicable to Street Types 1, 2, and 3
- Bike rack as pictured is applicable to Street Types 1 and 2

USING THE STANDARDS

These standards provide additional specifications and guidance for elements placed within the public right-of-way in the HOD. They do not replicate existing specifications found in the City's PFM or Design Guidelines. For elements unique to the HOD, follow the Streetscape Standards detailed guidelines and specifications. If an element is not unique to the HOD, adhere to the City's PFM, or other referenced standard.

As the HOD public right-of-way are enhanced, conditions may change, technologies evolve, and techniques for managing traffic, stormwater and paving improve. If necessary, due to products no longer being available or to incorporate new products, new materials, or to respond to emerging needs and conditions, the Streetscape Standards can be amended with additions or deletions of specific elements as appropriate.

Priority

Where specifications or details exist for an element in multiple sources, priority is given to the Streetscape Standards as long as all safety and regulations are met.

Flexibility

Properties within the HOD reflect the City's historic roots and transportation network. As the City has developed and road widths expanded, the resulting relationship between the building wall, right-of-way line and curb face is varied. Adjustments to the Streetscape Standards may be necessary in certain conditions and may be made with appropriate approval provided by the City of Fairfax.

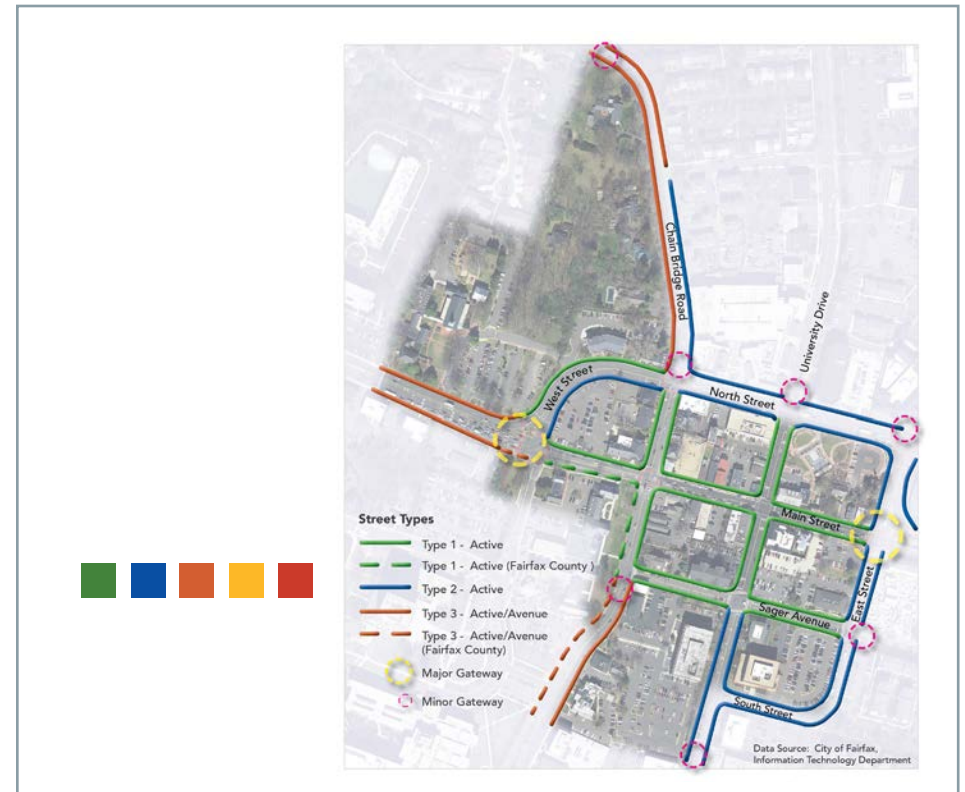

Street and Gateway Types

BENCH



BICYCLE RACK

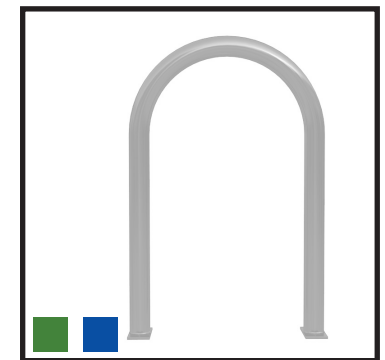

Streetscape Elements

Introduction

Future Modifications to Standards

The document recognizes that there may be appropriate changes to the included elements due to materials, maintenance practices, sustainability features, or if a vendor eliminates an element from its offerings. Until the Standards are updated, other elements may be used upon approval from the City.

Where to Find a Copy of the Standards

<https://www.fairfaxva.gov/government/community-development-planning/community-development/old-town-streetscape-plan-standards-and-main-street-streetscape-design>

JURISDICTION

City of Fairfax, VA.

ADOPTED DATE

July 9, 2019



STREETSCAPE ZONES

Streetscape Zones

ZONE DEFINITIONS

The Streetscape Standards provide tools to improve and enhance pedestrian and bicycle safety and mobility within the public right-of-way, to encourage additional economic activity within the City's downtown, and to strengthen connectivity between destinations. As illustrated in the adjacent diagram, for purposes of the Streetscape Standards, the public right-of-way has been divided into four zones:

- Roadway Zone
- Furnishings Zone
- Pedestrian Zone
- Gathering Zone

ROADWAY ZONE

The Roadway Zone includes travel and turn lanes, on-street parking lanes, bike lanes, bulb outs—anything that extends beyond the traditional curb line into the right-of-way and street or roadway.

FURNISHINGS ZONE

The Furnishings Zone varies in width, but where pedestrian lights are to be incorporated, the minimum required width is three feet. Dependent on space available, this zone may also accommodate elements such as street trees, landscape plantings which may incorporate infiltration systems for stormwater, benches, trash cans, bus stops, bollards, pedestrian lighting with banners and/or flowering baskets, seasonal lighting, cross street banners, public art, and historical markers.

PEDESTRIAN ZONE

The Pedestrian Zone requires a minimum width of 5 feet¹, clear of any obstacles or impediments to pedestrian use. The current Americans with Disabilities (ADA) Public Rights-of-Way guidelines require a clear zone of 4 feet, while the proposed guidelines call for a 5 foot clear zone.

¹ <https://www.access-board.gov/guidelines-and-standards/streets-sidewalks/public-rights-of-way/proposed-rights-of-way-guidelines/chapter-r3-technical-requirements> (Minimum pedestrian clear width per Public Rights of Way Guidelines is 4 feet wide, with City requiring a minimum pedestrian clear width of 5 feet - for purposes of the Streetscape Standards, a minimum width of 5 feet is employed.)



Cross-section illustrating zones: Streetscape Standards for the public right-of-way

When buildings are located directly on the Pedestrian Zone edge, and there is no space to accommodate a Gathering Zone, the effective width of the Pedestrian Zone is reduced by one foot due to the shy from the building edge.

GATHERING ZONE

The Gathering Zone is located between the Pedestrian Zone and the building face and/or private property line. It may include building entry and access, a bus shelter, outdoor dining, landscape planting or ornamental pots, a bench, or temporary signboards if permitted by City ordinances. Where space is limited in the Furnishings Zone, elements such as street trees or trash cans that cannot be accommodated within the Furnishings Zone may be located in the Gathering Zone.

Streetscape Zones

ZONE DIMENSIONS

The cross section on the following page illustrates vertical and horizontal dimensions that apply to all improvements within the public right-of-way and implementation of the Streetscape Standards.

ROADWAY ZONE

Vertical

A minimum of 15 feet of vertical clearance from the pavement surface to the bottom of an object such as a banner or street tree branch is required to ensure adequate space for truck and bus passage. As measured, the 15 foot vertical clearance includes both the space over the Roadway Zone and 18 inches beyond the curb face in the Furnishings Zone.

Horizontal

The width of the Roadway Zone varies, but these standards are focused on the areas immediately adjacent to the curbs within the overall zone. On-street parking or loading spaces are accommodated by an 8 foot wide space, with travel and turn lanes ranging from 10 to 12 feet within the HOD. Streetscape improvements are most likely to borrow space from the parking/loading space, for use as bulb outs at intersections or mid-block, for temporary pop-up installations, repurposing a vehicle parking space as a cycle stall, or incorporating stormwater infiltration improvements.

FURNISHINGS ZONE

Vertical

This zone is subject to the same required 15 foot vertical clearance for any objects placed within the zone that are within 18 inches of the curb face.

Outside of the 15 foot vertical clear zone, objects attached to pedestrian light poles must maintain a 7 foot clearance for hanging baskets and a 9 foot vertical clearance for any banners.

Horizontal

Minimum widths for the Furnishings Zone is 3 feet in Active Street Types 1 and 2. The maximum width is 10 feet for all street types. There is no minimum width for Active Street/Avenue 3, the Pedestrian Zone may abut the curb line.

PEDESTRIAN ZONE

Vertical

A minimum vertical clear zone of 9 feet is required for objects such as banners placed or overhanging the Pedestrian Zone. Baskets that encircle the post of the pedestrian lights must have a 7 foot clearance from the sidewalk.

Horizontal

The minimum clear width (no impediments or obstacles) for the Pedestrian Zone is 5 feet. The City's Zoning Ordinance requires a minimum sidewalk width of 10 feet for new construction which includes space allocated for all three zones: Furnishings, Pedestrian, and Gathering.

GATHERING ZONE

Vertical

A minimum vertical clear zone of 7 feet is required.

Horizontal

There is no minimum or maximum width per the Streetscape Standards.

Streetscape Zones

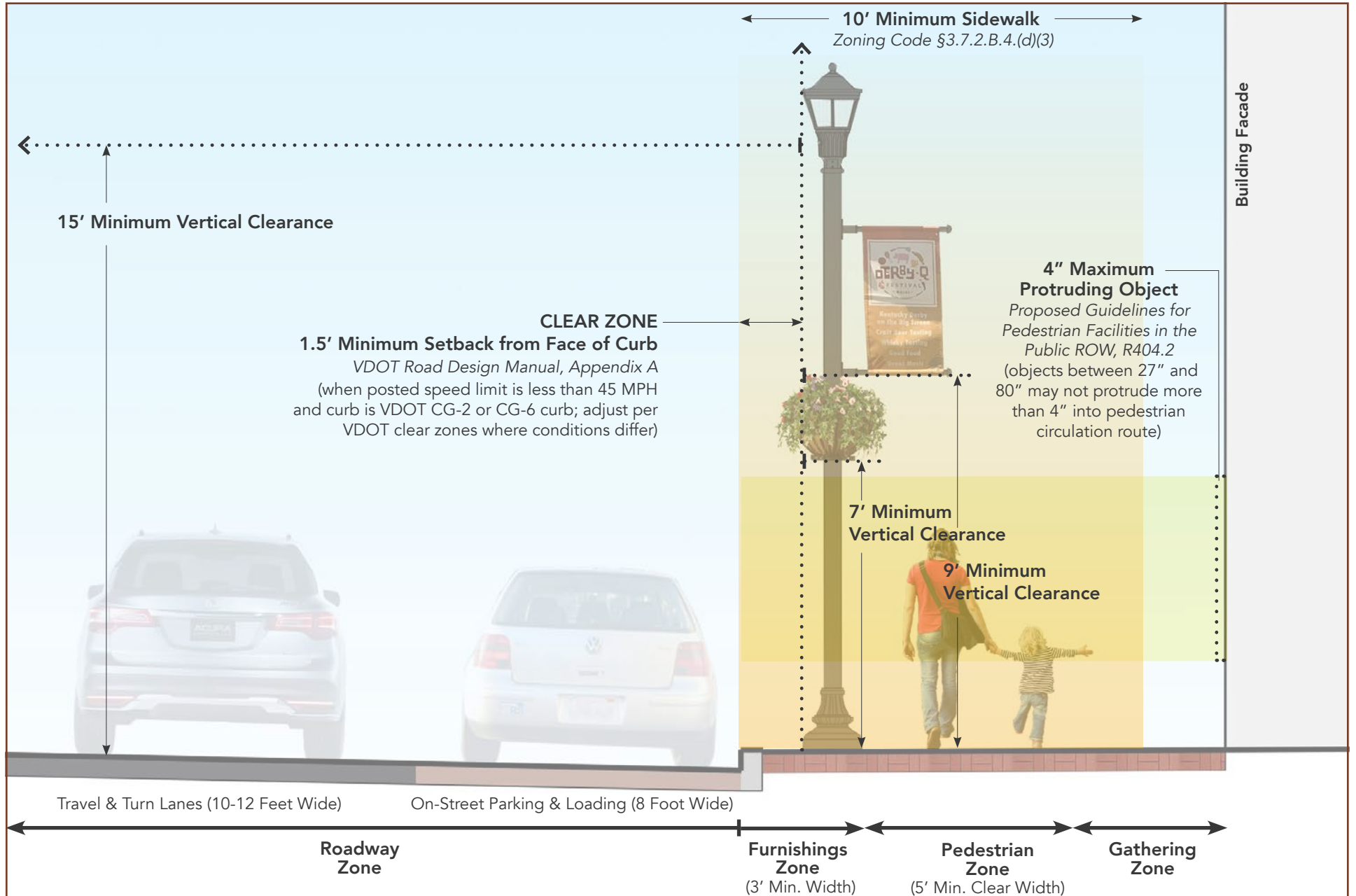

Minimum offsets within each zone

Streetscape Zones

DIMENSIONS APPLICABLE TO ALL STREETScape ZONES

VDOT Clear Zone

Clear Zones apply to all Streetscape Zones. Dimensions for the clear zone is based on the posted speed limit and the type of road edge or curb. Fixed objects must meet the VDOT clear zone requirements¹ or pass current crash test requirements for obstacles within street clear zones. For example, where the posted speed limit is less than 45 MPH², and a barrier-type curb is provided (VDOT CG-2 or CG-6 curb details), a minimum lateral offset of 1.5 feet from the face of curb should be provided. For roadways without barrier curb, reference to Table A-2-1 in VDOT's standards is required. Objects must meet VDOT clear zone requirements for the posted or design speed limit and road edge condition.

Posted Speed Limit

The majority of the streets within the HOD have posted speed limits of 25 MPH, with the exception of Main Street west of North Street (35 MPH), Old Lee Highway, north of North Street (30 MPH) and Chain Bridge Road south of Massey Drive (30 MPH).

Approval Letter or Waiver

A letter of approval or waiver from the City of Fairfax may be required for installations maintaining or adhering to a minimal clear zone per AASHTO guidance for roads with posted or design speed of 25 MPH and placement of an object 18 inches from the face of the curb.

Protruding Object (PROWAG)

Elements may not intrude into pedestrian space within any clear walk area, whether designated as the Pedestrian Zone or not, more than 4 inches between the vertical distance 27 inches above grade and 80 inches above grade unless there is a base provided.

Sight Triangle

Visual Clearance (Safe Sight Triangles) per the City's Zoning Ordinance §4.3.4 do not apply in the Old Town Fairfax Historic Overlay District (§3.7.2.B.6.). Although visual clearance in accordance with the standards of the public facilities manual on any corner lot within the HOD is not required, best practices suggest that care be taken in the placement of new objects such as banners and plantings to minimize any visual obstruction within the site triangle, definition of such can be found in VDOT Standards.

¹ VDOT *Road Design Manual*, Appendix A, Section A-2, Clear Zone/Lateral Offset Guidelines

² VDOT *Roadways with Curb*, page A-27

Streetscape Zones

ZONE USES

Each zone performs a different service and houses different uses within the public right-of-way. Supporting these uses are specific elements and construction details, included or referenced within this document in the section Streetscape Elements. The specific division within the Streetscape Elements is noted in parentheses. Actual placement of any of these items within each zone is site specific, subject to available space and requirements.

ROADWAY ZONE USES

- Banner pole - cross street - mid-block bulb out (Furnishings)
- Bulb out at intersection and/or mid-block location (Pavement)
- Cycle stall (Furnishings)
- Infiltration and stormwater management
- Loading zone (Pavement)
- On-street parking for vehicles (Pavement)
- On-street bike lane separate from travel lane
- Plant lists - Bioretention Facilities, Groundcovers, Urban Street trees (Plants)
- Street tree
- Temporary event or popup
- Travel/turn lane

FURNISHINGS ZONE USES

- Banner - attached to pedestrian light pole (Furnishings)
- Banner pole - cross street - mid-block bulb out (Furnishings)
- Bench - where space is sufficient or in conjunction with a transit stop (Furnishings)
- Bicycle rack (Furnishings)
- Bollard/barrier (Furnishings)
- Bus shelter - where adequate space exists (Furnishings)
- Decorative lighting (Lighting)
- Gateways - major or minor (Identifiers)
- Historic marker (Identifiers)
- Infiltration - stormwater
- Lawn
- Ornamental planting
- Pedestrian light (Lighting)
- Plant lists - Groundcovers, Urban Street trees, Hanging/Hayrack baskets, Planter pot (Plants)

- Planter - Hanging basket attached to pedestrian light pole (Furnishings)
- Planter - Hayrack basket attached to pedestrian light pole (Furnishings)
- Planter - Pot (Furnishings)
- Public art (Identifiers)
- Street tree
- Trash can (Furnishings)
- Tree grate (Furnishings)
- Wayfinding (Identifiers)

PEDESTRIAN ZONE USES

- Public art (Identifiers)

GATHERING ZONE USES

- Banner - attached to pedestrian light pole (Furnishings)
- Bench (Furnishings)
- Bicycle rack (Furnishings)
- Building/business entry Outdoor dining
- Bus shelter (Furnishings)
- Cycle stall (Furnishings)
- Decorative Lighting (Lighting)
- Drinking fountain (Furnishings)
- Gateways - major or minor (Identifiers)
- Historic marker (Identifiers)
- Lawn
- Ornamental planting
- Outdoor dining
- Pedestrian light (Lighting)
- Plant lists - Groundcovers, Urban Street trees, Hanging/Hayrack baskets, Planter pot, Vegetated walls, Utility corridors (Plants)
- Planter - Hanging basket attached to pedestrian light pole (Furnishings)
- Planter - Hayrack basket attached to pedestrian light pole (Furnishings)
- Planter - Pot (Furnishings)
- Public art (Identifiers)
- Street tree
- Trash can (Furnishings)
- Temporary signboard and display - per ordinance allowance
- Tree grate (Furnishings)
- Wayfinding (Identifiers)
- Weather protection/awning at edge of building facade



STREET TYPES and GATEWAYS

Street Types and Gateways



TYPE DEFINITIONS

The City of Fairfax 2035 Comprehensive Plan, Chapter 3: Multimodal Transportation defines two type of streets within the HOD: Active and Avenue. Active Streets connect multiple destinations within a neighborhood, are more mixed-use or commercial in nature than residential street typologies, and are designed to create a comfortable environment for strolling, shopping, and dining while at the same time accommodating circulation by pedestrians, bicycles, cars and trucks, and in some cases transit vehicles. Avenues carry moderate volumes of traffic, using one travel lane in each direction. Significant volumes of traffic can be found in this typology, with vehicles passing through to other local or area destinations.

Per the plan, the streets within the HOD are primarily Active Streets with a small segment categorized as Avenues. However, the Active Streets within the HOD when looked at a streetscape furnishings level have subtle differences in scale and use. Due to these more nuanced differences, the Active Streets and Avenues within the HOD were assigned one of three distinct street types within the Streetscape Standards.

As illustrated on the right, each street within the HOD is assigned a street type, and gateway locations noted. A solid line indicate a street type location within the City of Fairfax's boundaries. A dashed line indicates a similar condition and street type, but for a location outside of the City's jurisdiction. Major and minor gateways are indicated by a dashed circle.

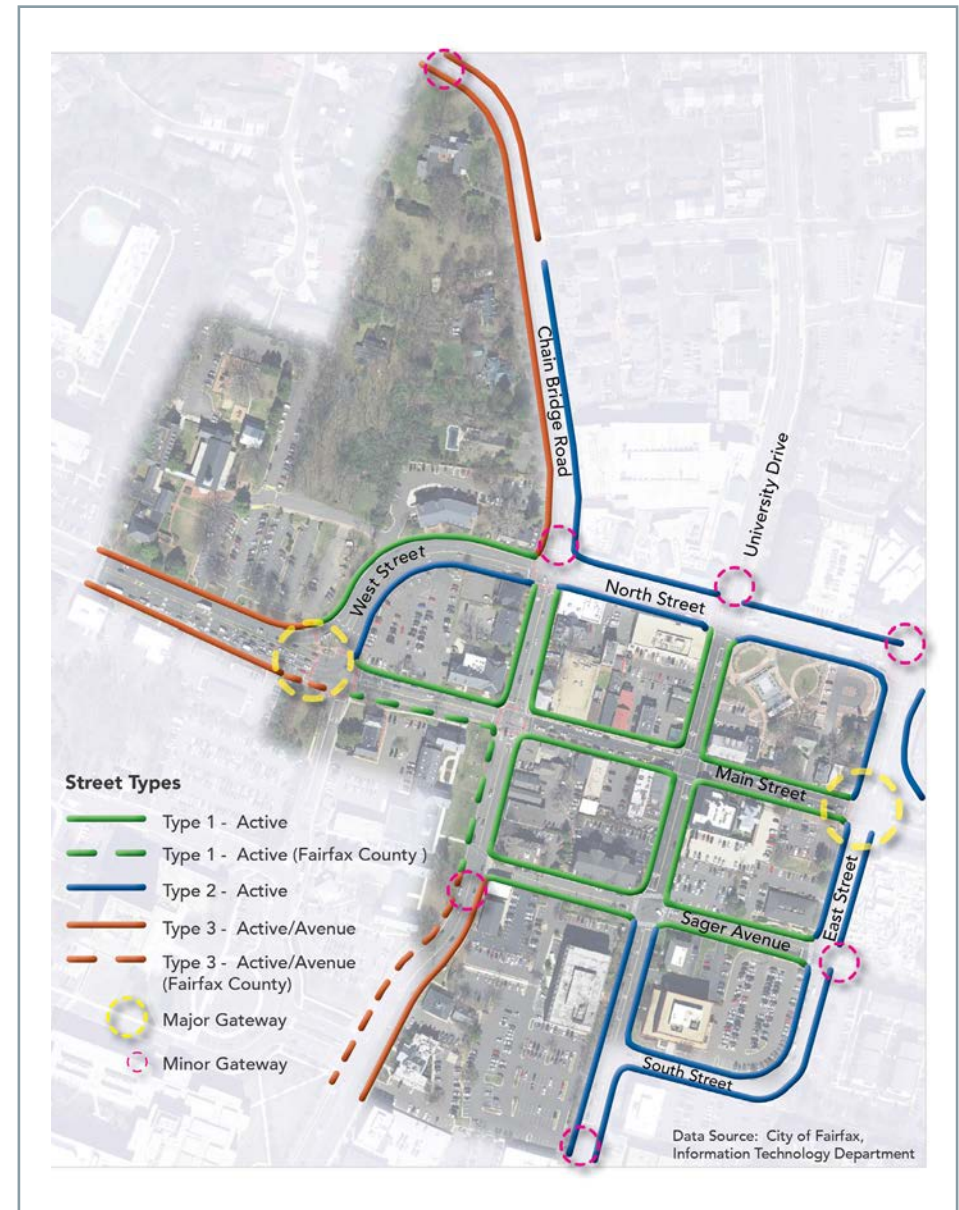

Diagram illustrating location of street types and gateways within the HOD

Street Types and Gateways



ACTIVE STREET TYPE 1

Streets assigned to the category of Active Street Type 1 are the streets within the four core blocks of downtown. These streets and associated right-of-way are the most narrow - usually less than 50 feet wide, generally have lower traffic volumes. Generally buildings are located within 15 feet of the face of the curb, without surface parking or driveways interrupting the space between the building and the street. Many of the adjacent properties are historic, with most buildings, historic or not, no more than two stories high. Sidewalk widths are narrow, and leave little or no room for the addition of desired streetscape elements such as street trees, or furnishings such as benches without the cooperation of adjacent private property owners. Several areas have been identified in prior City studies as opportunities for sidewalk expansion.

Due to the generally narrow width of the public right-of-way, space is limited for streetscape improvements. Due to such limitations, street trees are not required, although hanging baskets and banners mounted on the pedestrian light poles are encouraged. Although there is little room available to place planter pots in the public right-of-way while retaining a five foot clear pedestrian zone, planters on adjacent private property are encouraged. Curb extensions from the existing curb line into street to create bulb outs at intersections may provide additional space to locate streetscape elements. Agreements between the City and some private property owners may create opportunities to extend the depth of the public sidewalk. Additional street tree plantings within Active Street Type 1 will likely occur in a bulb out or on private property.

Active Street Type 1 streets are illustrated in green on the adjacent diagram. Solid lines indicate a location within the City's boundaries and a dashed line indicates a location outside of the City's jurisdiction.

Zone Elements

The following list does not represent a required list, but provides guidance for where elements, if space permits, are to be located on this street type.

Roadway Zone

- Banner pole - cross street - mid-block bulb out
- Bulb out at intersection and/or mid-block location
- Cycle stall

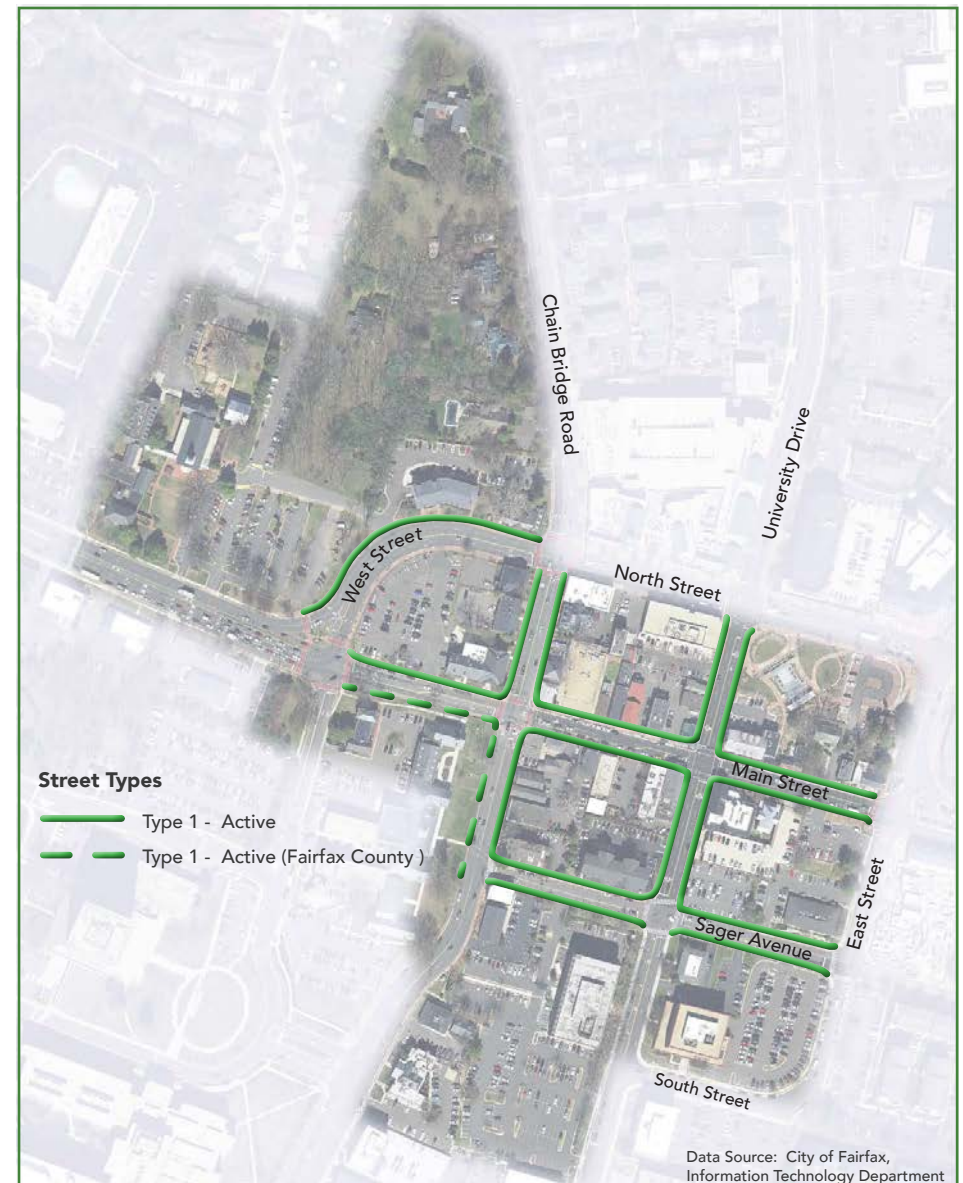

Diagram illustrating the location of Active Street Type 1 within the HOD

Street Types and Gateways



- Infiltration and stormwater management
- Loading zone
- On-street parking for vehicles
- On-street bike lane separate from travel lane
- Plant lists - Bioretention Facilities, Groundcovers, Urban Street trees (Plants)
- Street tree
- Temporary event or popup
- Travel/turn lane

Furnishings Zone

- Banner - attached to pedestrian light pole
- Banner pole - cross street - mid-block bulb out
- Bench - where space is sufficient or in conjunction with a transit stop
- Bicycle rack
- Bollard/barrier
- Bus shelter - where adequate space exists
- Decorative lighting
- Historic marker
- Infiltration - stormwater
- Ornamental planting
- Pedestrian light
- Plant lists - Bioretention facilities, Groundcovers, Urban Street trees, Hanging/Hayrack baskets, Planter pot (Plants)
- Planter - hanging basket
- Planter - hayrack basket
- Planter - pot
- Public art
- Street tree
- Trash can
- Tree grate
- Wayfinding

Pedestrian Zone

- Public art



*Looking east on Main Street towards East Street,
Main Street is an Active Street Type 1*

Street Types and Gateways



Gathering Zone

- Banner - attached to pedestrian light pole
- Bench
- Bicycle rack
- Building/business entry
- Bus shelter
- Decorative lighting
- Drinking fountain
- Ornamental planting
- Outdoor dining
- Pedestrian light
- Plant lists - Groundcovers, Urban Street trees, Hanging/Hayrack baskets, Planter pot, Vegetated walls, Utility corridors (Plants)
- Planter - pot
- Planter - Hanging basket
- Planter - Hayrack basket
- Public art
- Street tree
- Temporary signboard and display - per ordinance allowance
- Trash can
- Wayfinding
- Weather protection/awning at edge of building facade

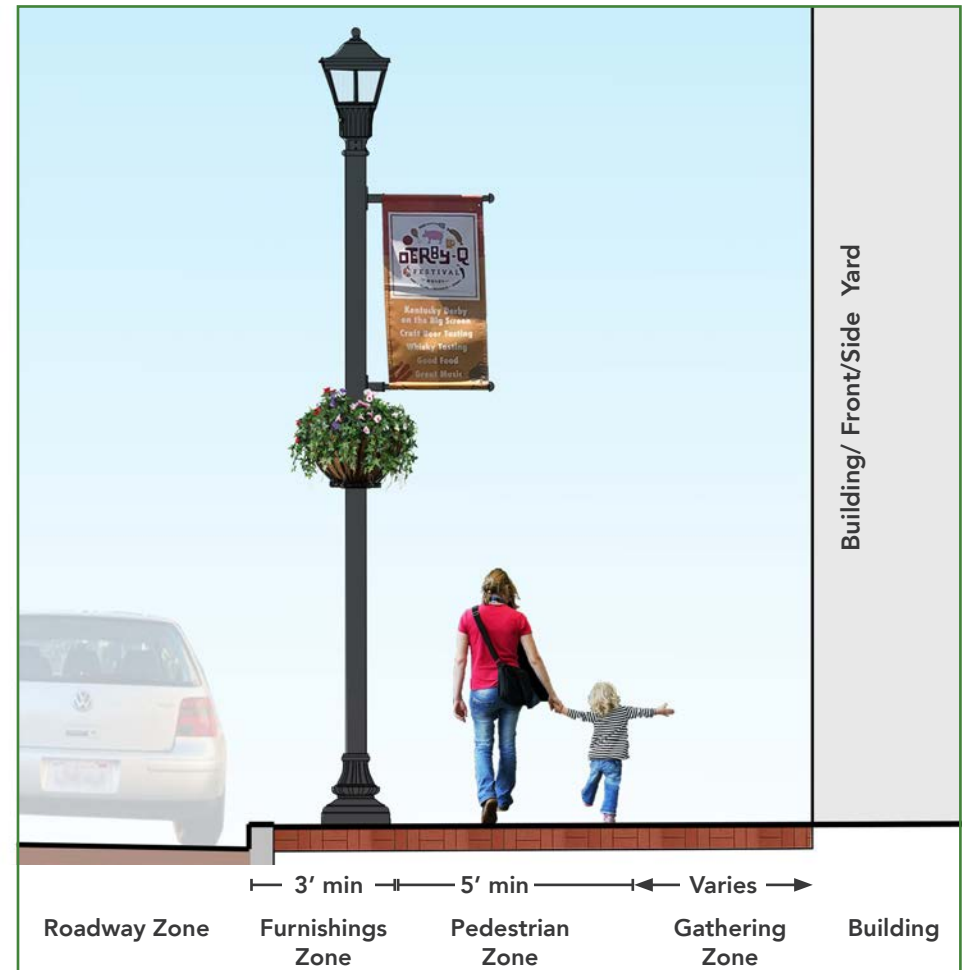

Active Street Type 1 cross section

Street Types and Gateways

ACTIVE STREET TYPE 2

Streets assigned to the category of Active Street Type 2 surround the four core blocks of downtown, as illustrated in blue on the diagram. Solid lines indicate a location within the City's boundaries and a dashed line indicates a location outside of the City's jurisdiction.

Active Street Type 2 streets tend to have a slightly larger right-of-way, between 50 feet and 55 feet wide. Traffic volumes are slightly higher than Type 1, adjacent buildings are larger and the building setback deeper than those located on Type 1 streets. In general, there is more room within the public right-of-way for streetscape enhancements. There are areas within this street type where public right-of-way is narrow. These narrow sections may be remedied with an agreement between the City and the private property owning to allow for public sidewalk expansion.

The wider public right-of-way provides more opportunities to add streetscape enhancements, including outdoor dining and seating areas, street tree plantings, decorative pots, public art, and historic markers in both the Furnishings and Gathering Zones. Where adequate vertical clear space is available, pedestrian light poles may have double banner arms attached.

As in Street Type 1, the placement of benches, trash cans, and other streetscape furnishings is encouraged.

Zone Elements

The following list of elements appropriate to each zone within the Active Street Type 2 does not represent a required list, but guidance for where elements, if space permits, are to be located on this street type.

Roadway Zone

- Banner pole - cross street - mid-block bulb out
- Loading zone
- Infiltration and stormwater management
- On-street parking for vehicles
- On-street bike lane separate from travel lane
- Travel/turn lane



Diagram illustrating the location of Active Street Type 2 within the HOD

Street Types and Gateways



Furnishings Zone

- Banner - attached to pedestrian light pole
- Banner pole - cross street - mid-block bulb out
- Bench - where space is sufficient or in conjunction with a transit stop
- Bicycle rack
- Bollard/barrier
- Bus shelter - where adequate space exists
- Cycle stall
- Decorative lighting
- Gateways - Major
- Gateways - Minor
- Historic marker
- Infiltration - stormwater
- Ornamental planting
- Pedestrian light
- Plant lists - Bioretention facilities, Groundcovers, Urban Street trees, Hanging/Hayrack baskets, Planter pot (Plants)
- Planter - hanging basket
- Planter - hayrack basket
- Planter - pot
- Public art
- Street tree
- Trash can
- Tree grate
- Wayfinding

Pedestrian Zone

- Public art

Gathering Zone

- Banner - attached to pedestrian light pole
- Bench
- Bicycle rack
- Building/business entry
- Bus shelter
- Cycle stall
- Decorative lighting
- Drinking fountain
- Gateways - Major



Looking east on North Street towards University Drive, North Street is an Active Street Type 2

- Gateways - Minor
- Historic marker
- Ornamental planting
- Outdoor dining
- Pedestrian light
- Plant lists - Groundcovers, Urban Street trees, Hanging/Hayrack baskets, Planter pot, Vegetated walls, Utility corridors (Plants)
- Planter - hanging basket
- Planter - hayrack basket
- Planter - pot
- Street tree
- Temporary signboard and display - per ordinance allowance
- Trash can
- Tree grate
- Wayfinding
- Weather protection/awning at edge of building facade

Street Types and Gateways

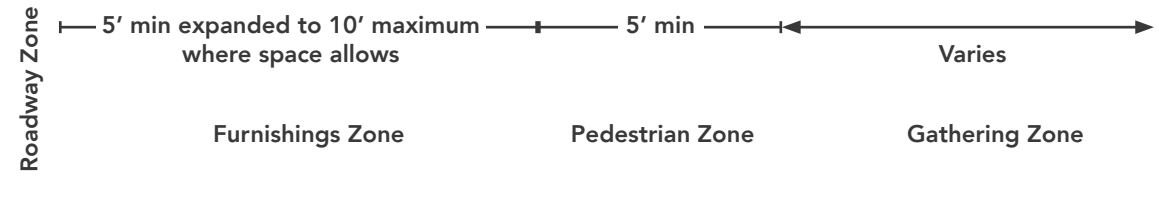
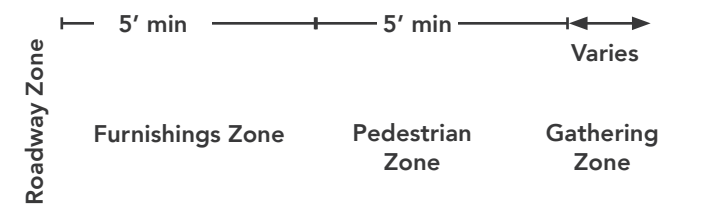

Potential cross sections for Active Street Type 2 with differing depth of public right-of-way

Street Types and Gateways



ACTIVE STREET/AVENUE TYPE 3

Streets assigned to Active Street/Avenue 3 are defined as both active and avenue in the Comprehensive Plan's Multimodal Transportation chapter. Located at the periphery of the HOD, these streets have the widest right-of-way, greater than 55 feet, the highest vehicle volumes, the largest buildings, few or no historic buildings, and for the most part are located outside of the National Historic District eligible boundaries. Uses ranging from single family residential properties to the Fairfax County Court Complex line these streets. Where existing public right-of-way is not sufficiently wide to accommodate streetscape enhancements, additional space may potentially be available through an agreement between the City and the private property owner.

Active Street/Avenue Type 3 are illustrated in brown on the adjacent diagram. Solid lines indicate a location within the City's boundaries and a dashed line indicates a location outside of the City's jurisdiction.

Depending on the amount of right-of-way available, and while meeting required clear dimensions, the Furnishings Zone may accommodate street tree plantings, double banners on the pedestrian light post, be paved and more urban in appearance. In other areas, the Furnishings Zone may take on a more residential character, with turf or other landscape plantings instead of paving. In some areas, the Pedestrian Zone may be separated from the Roadway Zone with a Furnishings Zone and in other areas the Furnishings Zone may be located away from the Roadway Zone as illustrated in the diagrams on page 27.

Zone Elements

The following list of elements appropriate to each zone within the Active Street Type 2 does not represent a required list, but guidance for where elements, if space permits, are to be located on this street type.

Roadway Zone

- Banner pole - cross street - mid-block bulb out
- Infiltration and storm water management
- On-street bike lane separate from travel lane
- Travel/turn lane

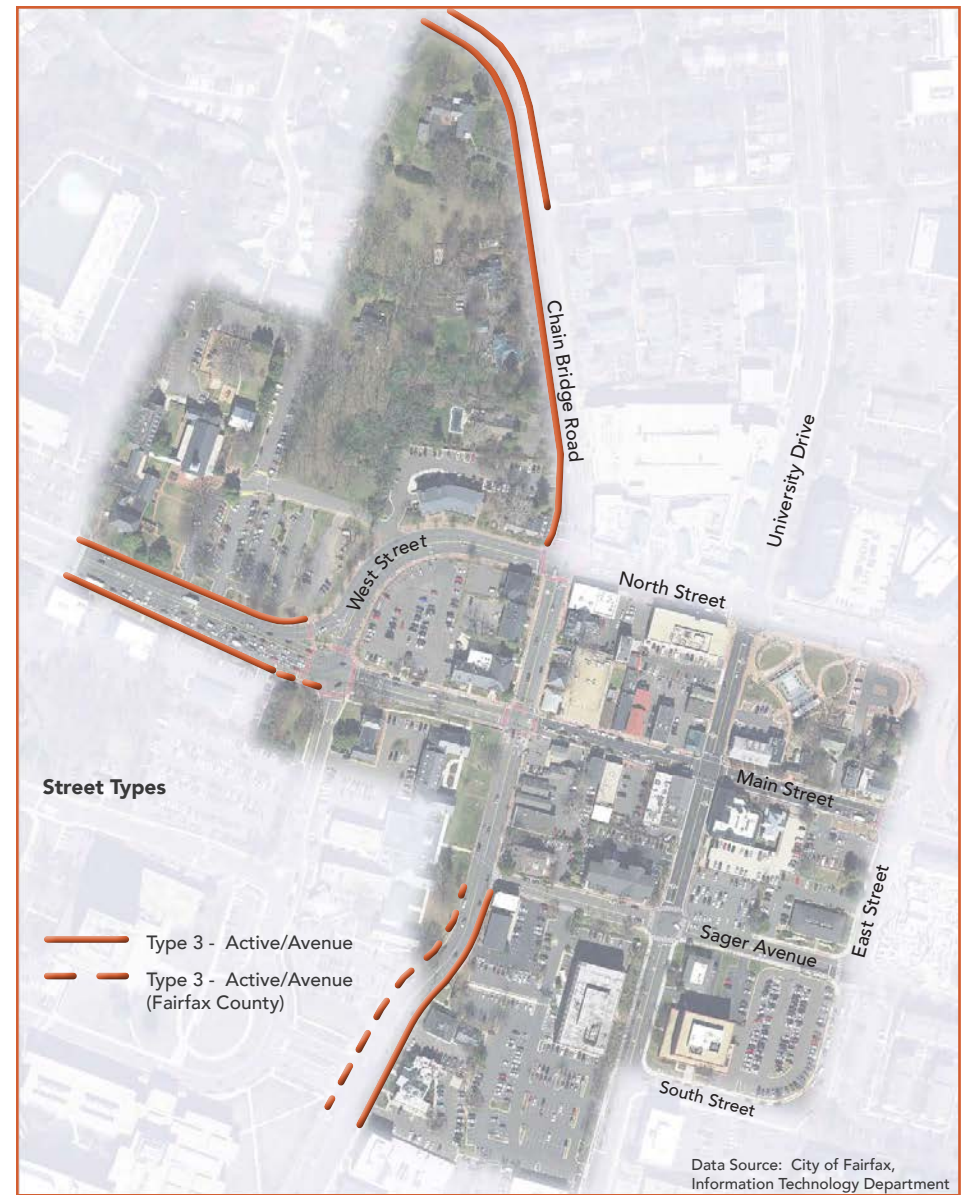

Diagram illustrating the location of Active Street/Avenue Type 3 within the HOD

Street Types and Gateways



Furnishings Zone

- Banner - attached to pedestrian light pole
- Banner pole - cross street - mid-block bulb out
- Bench - where space is sufficient or in conjunction with a transit stop
- Bicycle rack
- Bollard/barrier
- Bus shelter - where adequate space exists
- Decorative lighting
- Gateways - Major
- Gateways - Minor
- Historic marker
- Infiltration - stormwater
- Lawn
- Ornamental planting
- Pedestrian light
- Plant lists - Groundcovers, Urban Street trees, Hanging/Hayrack baskets, Planter pot (Plants)
- Planter - hanging basket
- Planter - hayrack basket
- Planter - pot
- Public art
- Street tree
- Trash can
- Tree grate
- Wayfinding

Pedestrian Zone

- Public art

Gathering/Building Access Zone

- Banner - attached to pedestrian light pole
- Bench
- Building/business entry
- Bus shelter
- Cycle stall
- Ornamental planting
- Pedestrian light
- Plant lists - Groundcovers, Urban Street trees, Hanging/Hayrack baskets, Planter pot, Vegetated walls, Utility corridors (Plants)



Looking north on Chain Bridge Road, north of Whitehead Street, this segment of Chain Bridge Road is categorized as an Avenue in the Comprehensive Plan's chapter on Multimodal Transportation

- Planter - hanging basket
- Planter - hayrack basket
- Planter - pot
- Street tree
- Trash can
- Tree grate
- Wayfinding
- Weather protection/awning at edge of building facade

Street Types and Gateways

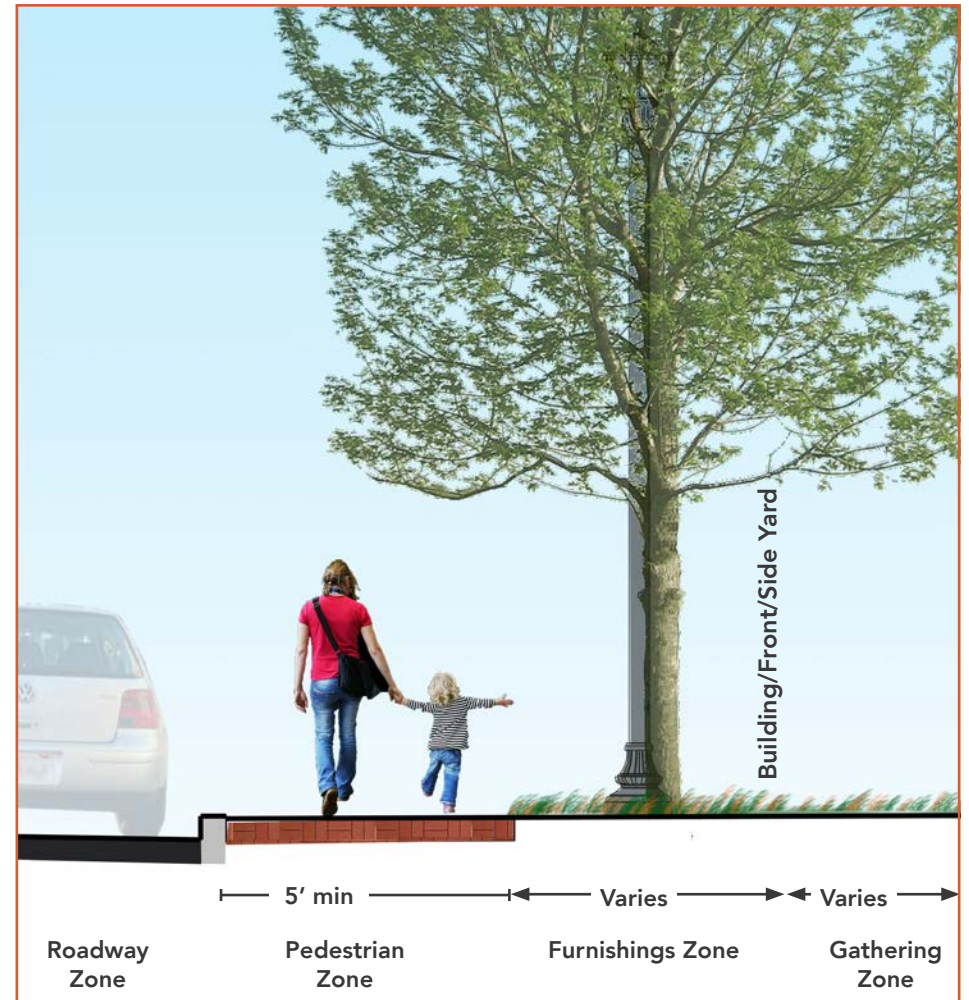
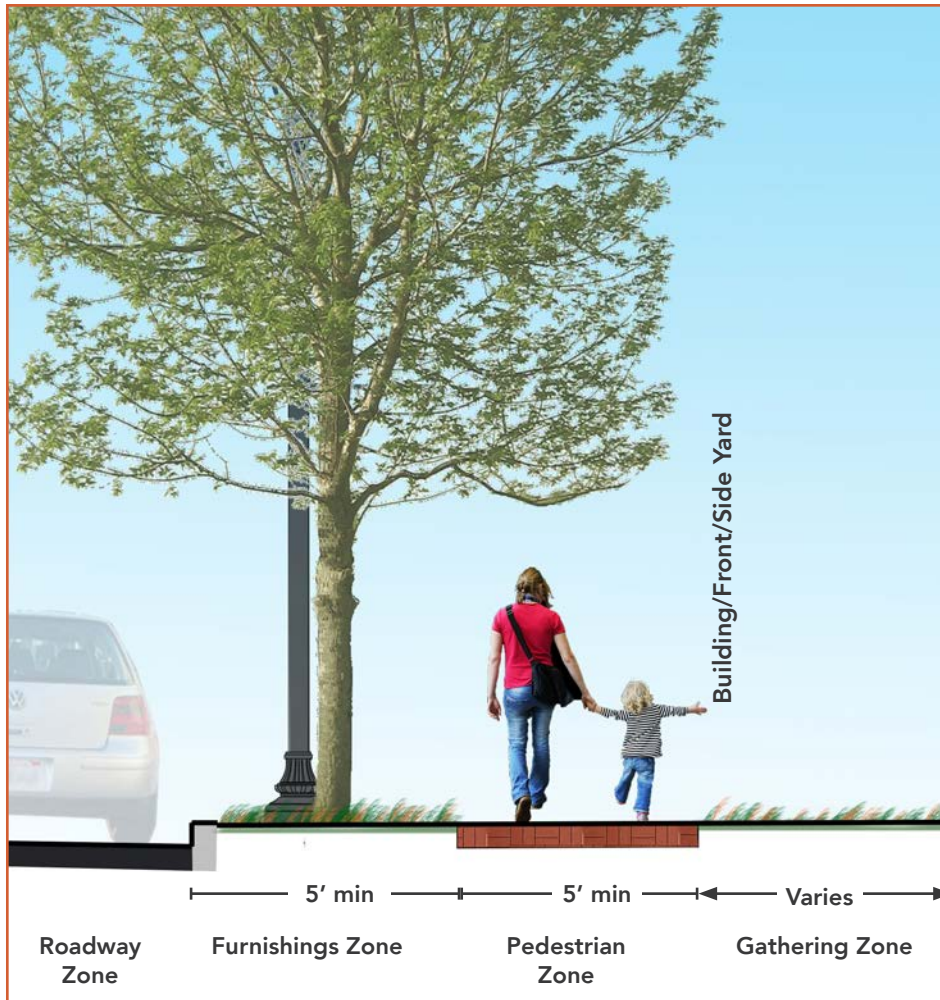

Potential cross sections for Active Street Type 3 with Furnishings Zones in different locations

Street Types and Gateways

GATEWAYS

Gateways signify to the viewer that they have arrived in a special place. They welcome people to the City's downtown and if successful, help to reinforce the City's brand and sense of place. Gateways are different in purpose and design from the City's wayfinding system. More than a sign, gateways serve as a marker that one is entering a specific and significant space - the Old Town Fairfax Historic Overlay District.

Major Gateways

Major Gateways are sited on the HOD's eastern and western perimeter, at the North/West and Main Streets and East and Main Streets intersections. These are illustrated on the adjacent diagram and indicated with a yellow circle.

The character of a Major Gateway differs from a Minor Gateway. A Major Gateway may be formed through the installation of public art, landscape plantings, decorative lighting, special paving, historic and interpretive signs, and site furnishings. The enhancements should be significant and reflect their immediate surroundings.

Main Street and North/West Streets

The two potential locations for a Major Gateway at the western end of Main Street include the northeast and southeast corners of the intersection with North/West Streets.

A Major Gateway on the southeast corner will require collaboration with Fairfax County and must be responsive to the adjacent historic properties. Located on the eastbound side of Main at the entry to the HOD, this is the preferred location visually, but the more challenging development location due to property ownership and topography.

A Major Gateway, located on the westbound side of Main Street on the intersection's northeastern corner, has better topography and public right-of-way available. Typically, such a feature is located on the side of the road shared by the intended viewer. This corner violates this principle, but its features may make it more appropriate to site the western Major Gateway to the HOD.

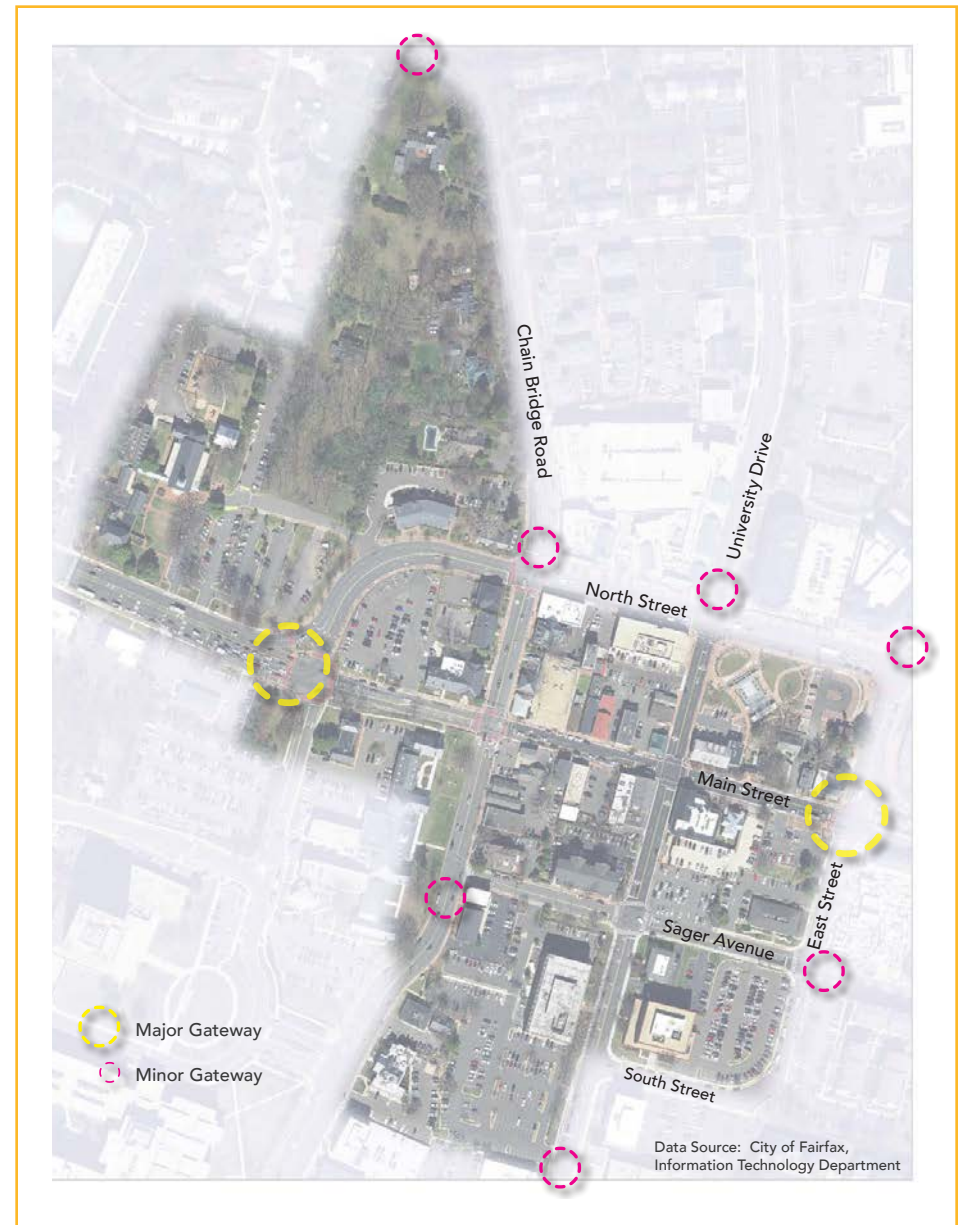

Diagram illustrating the location of Major and Minor Gateways within the HOD

Street Types and Gateways



Main Street and East Street

There are two potential locations for a Major Gateway at the eastern end of Main Street on the northwestern and southwestern corners of the intersection. Similar to the western location, the more appropriate location for the eastern Major Gateway may be the southwestern corner. Abutting the City-owned parking lot, there is space to develop a more complex gateway including lighting, planting, public art and other features. The other location, on the northwestern corner is less spacious and any features installed must be responsive to the historic properties immediately adjacent to it.

Minor Gateways

Minor Gateways are located at six entry points to the HOD. They are illustrated in the diagram on the preceding page by red circles. These six locations are:

- North Street and Chain Bridge Road
- North Street and University Drive
- North Street and East Street/Old Lee Highway
- East Street and Sager Avenue
- University Drive and HOD boundary south of Sager Avenue
- Chain Bridge Road and Sager Avenue

The current Welcome to Old Town Fairfax signs are well received. Placing them at these six locations, where possible in the median and surrounded by turf or mulch and no additional plantings, is a simple and elegant way to mark the perimeter of the City's HOD.

Regulations and Requirements

Any gateway feature located within the public right-of-way must meet VDOT clear zones standards and be in conformance with the City's ordinances and application of the VDOT's sight triangle guidance.

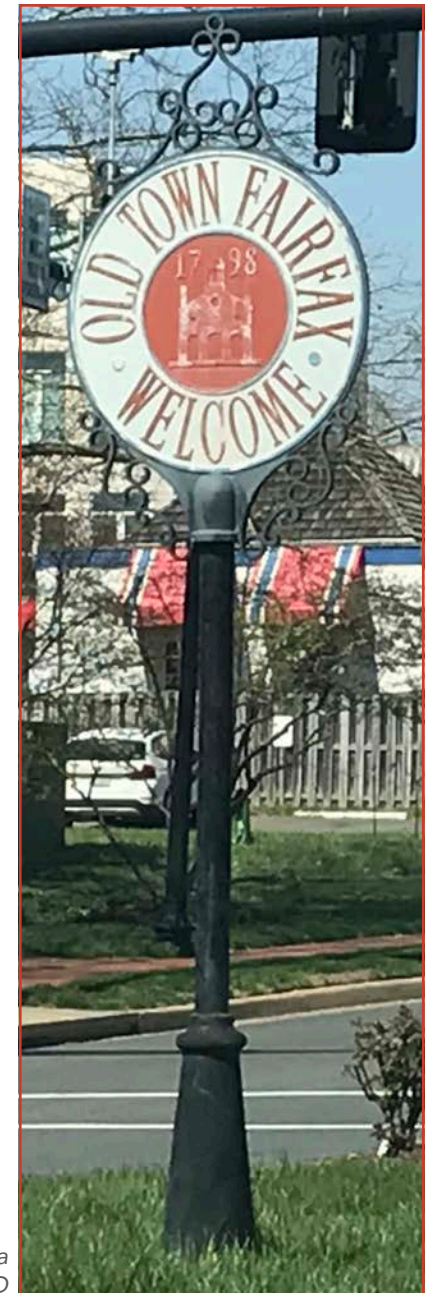

Existing sign can be used to signify a Minor Gateway within the HOD

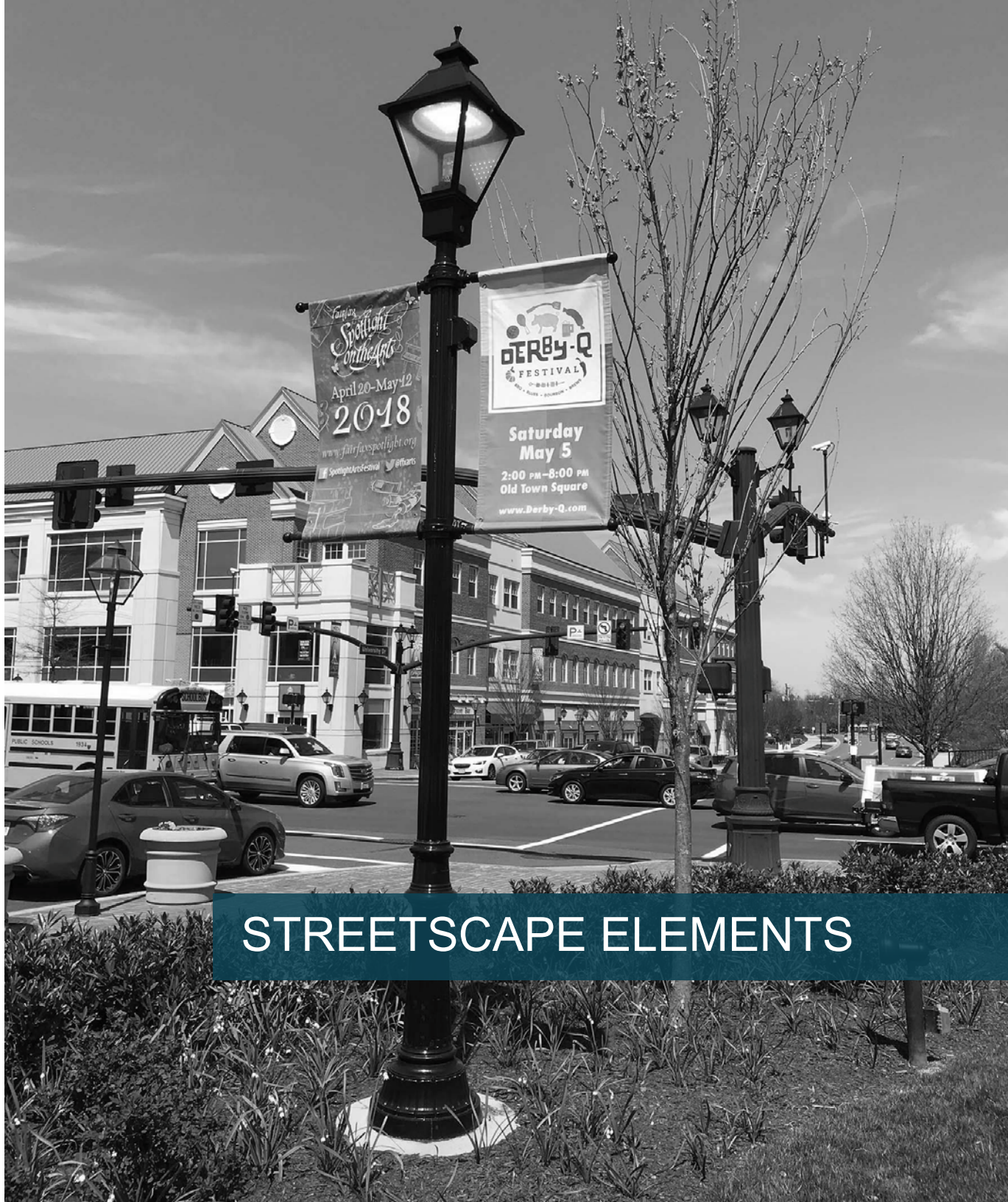

STREETSCAPE ELEMENTS

Streetscape Elements

ELEMENTS DEFINITION

This section houses the selected furnishings and materials for incorporation within the public right-of-way within the HOD. Keyed to street type and streetscape zone, this section provides both guidelines and where appropriate, specifications for elements such as pedestrian lighting and benches. If the element is already specified in another document such as the City of Fairfax Public Facilities Manual (PFM) or the City of Fairfax Design Guidelines, or VDOT Standards, the reader is directed to that source to avoid duplication of materials.

The section is divided into five divisions:

- Furnishings
- Lighting
- Pavement
- Plants
- Identifiers

DIVISION MATRIX SHEET

Each division opens with a matrix illustrating the elements found in the section. Listed alphabetically, with colored borders indicating whether specifications and details are found in the Streetscape Standards or elsewhere, the images summarize and provide a table of contents for the following pages within each division.

Small colored squares, on the lower left corner of each of the images match the element to street type.

GUIDANCE PAGE

Each element appropriate for use within the HOD is defined in the Streetscape Standards, whether specifications and details are contained in the document or elsewhere. The guidance page describes the element, its style, size, materials and color, location and setbacks, requirements, and potential source(s). Most elements accept an or equal to the specific vendor example. Some elements, such as the pedestrian lights do not allow an alternative to the specified detail.

SPECIFICATIONS

Elements that are unique to the HOD and not contained in the City's Public Facilities Manual (PFM), or specified in VDOT Standards are defined in this

FURNISHINGS

BENCH



BICYCLE RACK



A dark blue border indicates that this Element is unique to the HOD and specifications and details for its use are included in the Streetscape Standards.

PAVEMENT

CURB RAMP - CONCRETE

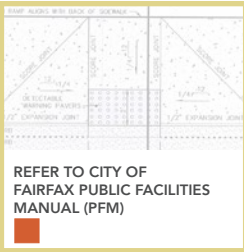

A light yellow-green border indicates that this Element is NOT unique to the HOD and specifications and details for its use are found where noted; general guidance for its use within the HOD is included in the Streetscape Standards, including Street Type use.

HOD Streetscape Standard

Other Standard

The applicability of each Element to Street Type is indicated by the colored square in the lower left hand corner on the Division Matrix Sheet.

Green indicates Active Street Type 1

Blue indicates Active Street Type 2

Brown indicates Active Street Type 3

How to read the Division Matrix Sheet regarding Elements

Streetscape Elements



document through vendor supplied specifications and cut sheets and detail drawings.

PRIORITY BETWEEN REFERENCES

If there are conflicting details or recommendations, the Streetscape Standards take precedence, per the approval of the City of Fairfax Planning Director and Director of Public Works.



Illustration of proposed pedestrian light fixture and pole with City of Fairfax banner

Streetscape Elements

FURNISHINGS

DIVISION MATRIX SHEET

- Banner
- Banner pole - cross street
- Bench
- Bicycle rack
- Bollard/barrier
- Bus shelter
- Cycle stall
- Drinking fountain
- Planter - Hanging basket
- Planter - Hayrack basket
- Planter - Pot
- Trash can

Legend

- Active Street Type 1
- Active Street Type 2
- Active Street Type 3

□ HOD Streetscape Standard

□ Other Standard

BANNER



BANNER POLE - CROSS STREET

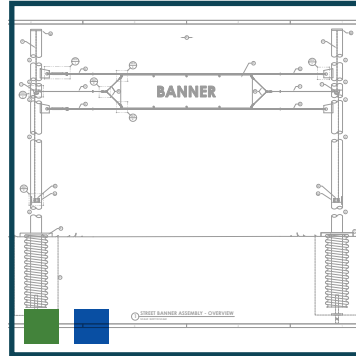

BENCH



BICYCLE RACK

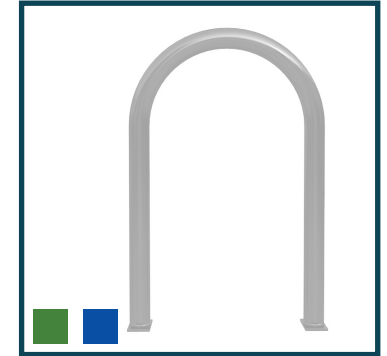

BOLLARD/BARRIER

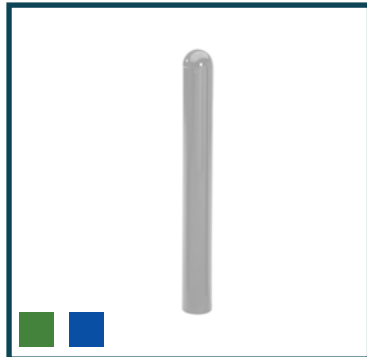

BUS SHELTER



CYCLE STALL



DRINKING FOUNTAIN



PLANTER - HANGING BASKET



PLANTER - HAYRACK BASKET



PLANTER - POT

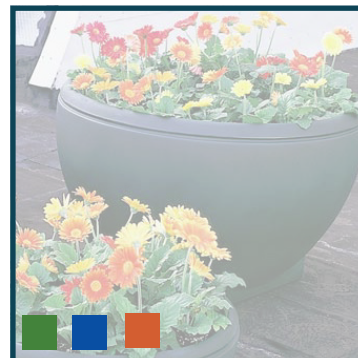

TRASH CAN



Streetscape Elements



FURNISHINGS, CONTINUED DIVISION MATRIX SHEET

- Tree grate

TREE GRATE



Legend

-  Active Street Type 1
-  Active Street Type 2
-  Active Street Type 3

 HOD Streetscape Standard

 Other Standard

Streetscape Elements

BANNER

Description

Two types of seasonal and event oriented banners: vertical format attached to pedestrian light posts or street-width banner attached to banner pole designed specifically for such use

Style

- Use City of Fairfax Parks & Recreation template for vertical banners attached to pedestrian light poles
- TBD by City of Fairfax Parks & Recreation for design template for cross-street banner

Size

- 24" x 48" double-sided vertical banner for attachment to pedestrian light pole fixed banner arms (current banners produced by Fast Signs)
- 3' to 4' deep banner, width of street to be attached to banner poles designed specifically for such use

Materials and Color

- Will vary, dependent upon the event

Location and Setbacks

- Attach to pedestrian light poles or cross street banner poles, using fixed banner arms on poles
- Maintain 7 foot vertical clearance between bottom banner arm and ground surface when extended into the Pedestrian Zone
- Maintain 15 foot vertical clearance between bottom banner arm and ground surface when extended into the Roadway Zone
- When used in conjunction with a hayrack basket attached to the pole, maintain a 9 foot minimum vertical clearance between bottom banner arm and ground surface when banner extends into the Pedestrian Zone

Requirements

- Banner design factors in appropriate windloading



City of Fairfax banners in Old Town Square

Photo Credit: City of Fairfax

Source

- Fast Signs, City of Fairfax, VA or equal

Streetscape Elements

BANNER POLE - CROSS STREET

Description

Single purpose poles, specifically designed to support a street-wide banner

Style

- Simple clean lines, not decorative

Size

- Pole diameter substantial enough to withstand wind load of a banner sized to fit street width by 3 to 4 feet in height; outside diameter (OD) of base of pole for standard installations is approximately 10 inches to 12 inches, dependent on engineering reports assessing the specific location
- Typical clearance from surface of road crown to bottom of banner is 18 feet - 6 inches

Materials and Color

- Powder-coated metal
- Black
- Form to match that of pedestrian light poles (custom design)

Location and Setbacks

- Mid-block on Main Street between University Drive and Chain Bridge Road
- University Drive
- Chain Bridge Road
- Other appropriate entry points to the HOD

Requirements

- Colonial Flag - Pulley system for raising and lowering banner is incorporated within design, or equal

Source

Colonial Flag
9390 S 300 W, Sandy, UT 84070
800.782.0500 Ext 246 | Fax 801.562.1177
www.colonialflag.com

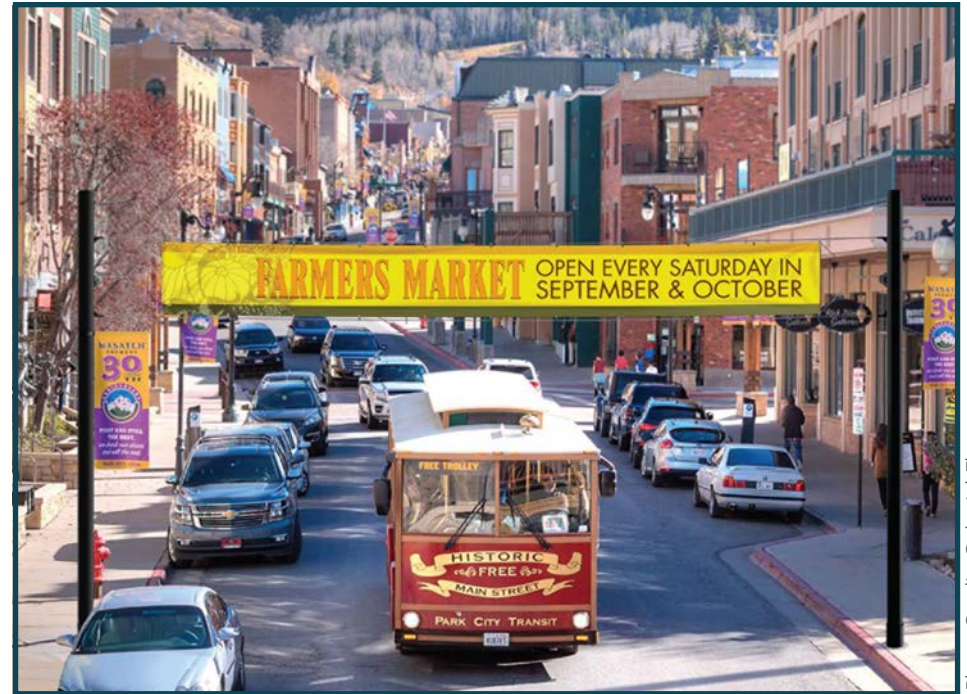

Cross-street banner in Park City, Utah

Photo Credit: Colonial Flag

Streetscape Elements

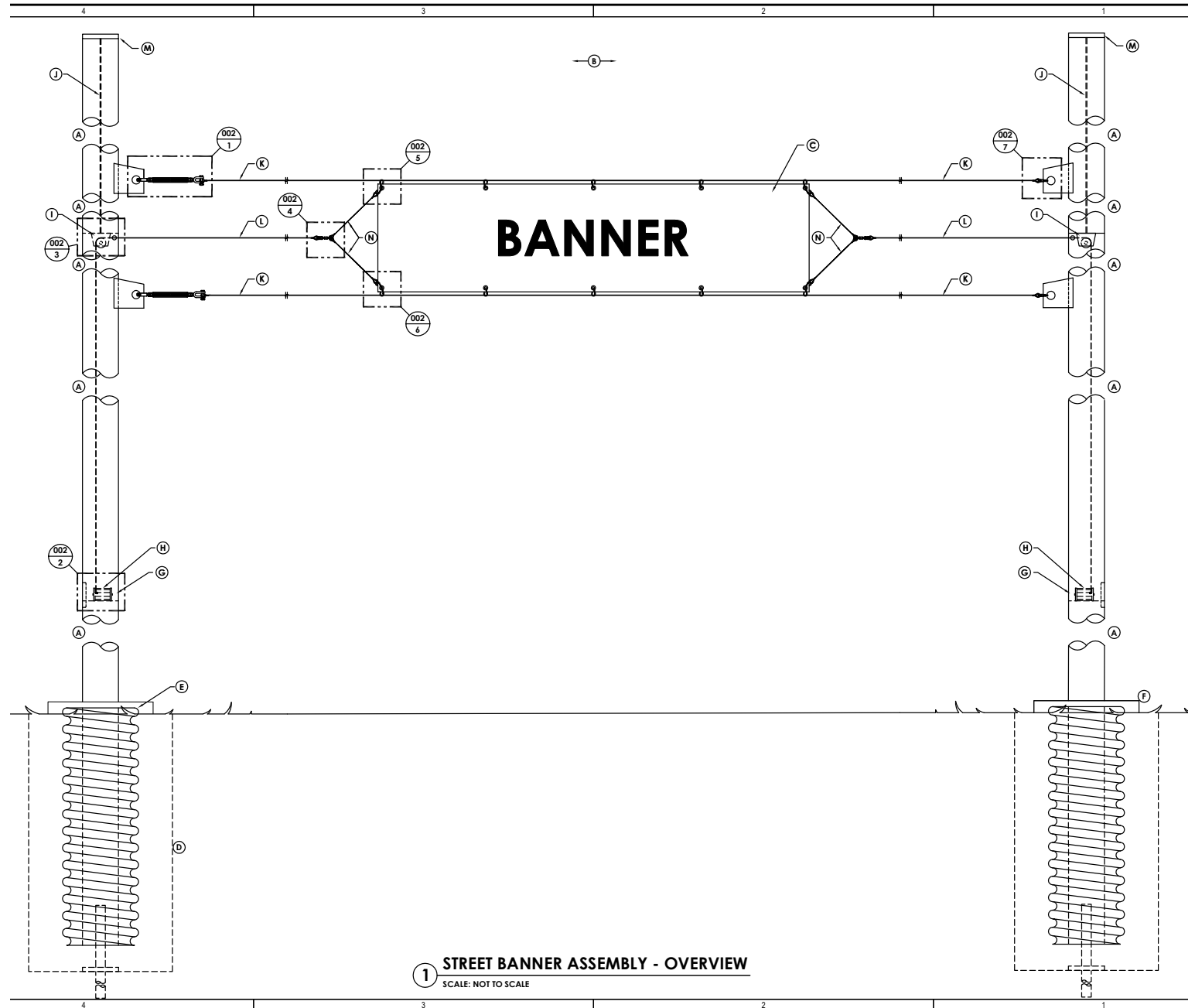

Although custom, the drawing illustrates the required cable pulley system that allows the banner to be raised and lowered from one side of the street.

Streetscape Elements

BENCH

Description

Benches to match those located in Old Town Square

Style

- Slatted seat back and seat
- End armrests, optional center armrest
- Plaque can be included

Size

- Six foot length

Materials and Color

- Powder-coated metal
- Black

Location and Setbacks

- 36" minimum setback from face of curb
- Minimum 1 bench per 350 linear feet (LF)/2 per block where space permits
- Bench face to be determined dependent upon site conditions

Requirements

- DuMor Site Furnishings, Bench 58 or equal
- Anchor with pin in footer located beneath paving surface

Sources

DuMor Site Furnishings
Bench 58, with optional mid-arm
P.O. Box 142
Mifflintown, PA 17059
www.dumor.com

Landscape Forms, Inc.
Scarborough Bench
7800 E. Michigan Ave.
Kalamazoo, MI 49048
www.landscapeforms.com

Keystone Ridge Designs, Inc.
Schenley Bench
670 Mercer Road
Butler, PA 16001
www.keystoneridgedesigns.com



City of Fairfax bench in Old Town Square

Streetscape Elements

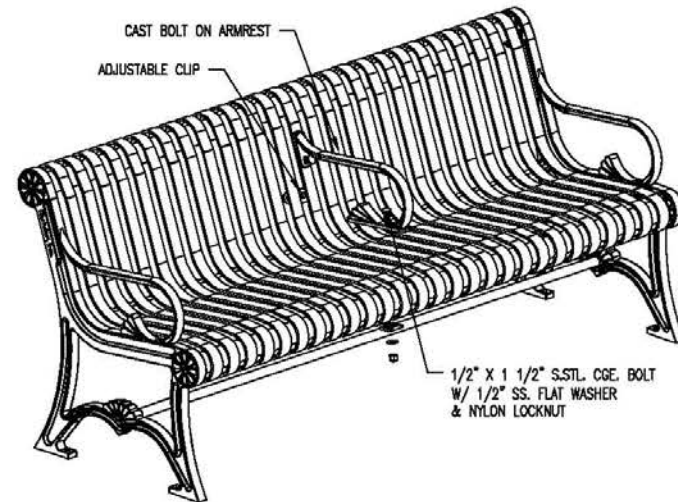
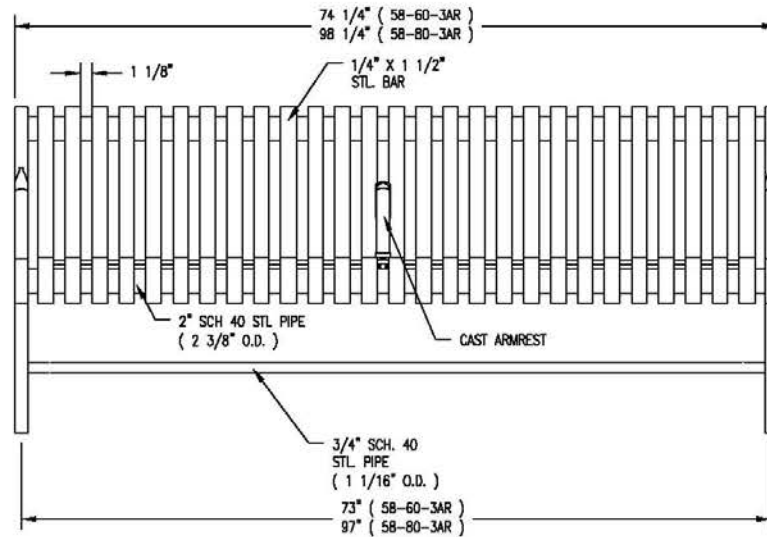
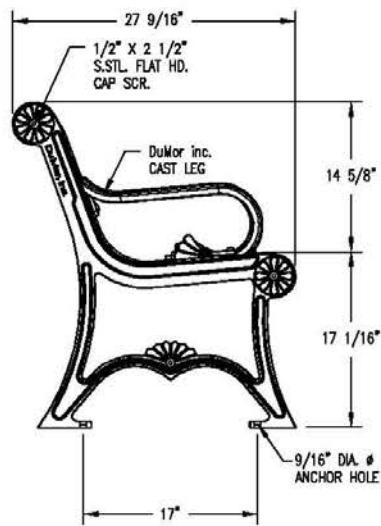

LENGTH OPTIONS

- 6' BENCH
- 8' BENCH

NOTES

- 1.) ALL STL. MEMBERS COATED W/ ZINC RICH EPOXY THEN FINISHED W/ POLYESTER POWDER COATING.
 - 2.) 1/2" X 3 3/4" EXPANSION ANCHOR BOLTS PROVIDED.
 - 3.) CUSTOM LETTERING AVAILABLE FOR RECESSED SIDE PANELS (TOTAL OF 37 SPACES)
- CUSTOM LETTERING (37 SPACES) _____



BENCH

DATE DRAWN : 03/22/94
 DRAWN BY : AWH
 DATE REV. : 11/21/99
 REV. BY : JSB

REV.
D

DRAWING NUMBER

58 SER-3AR

SHEET
1 OF 2

Streetscape Elements

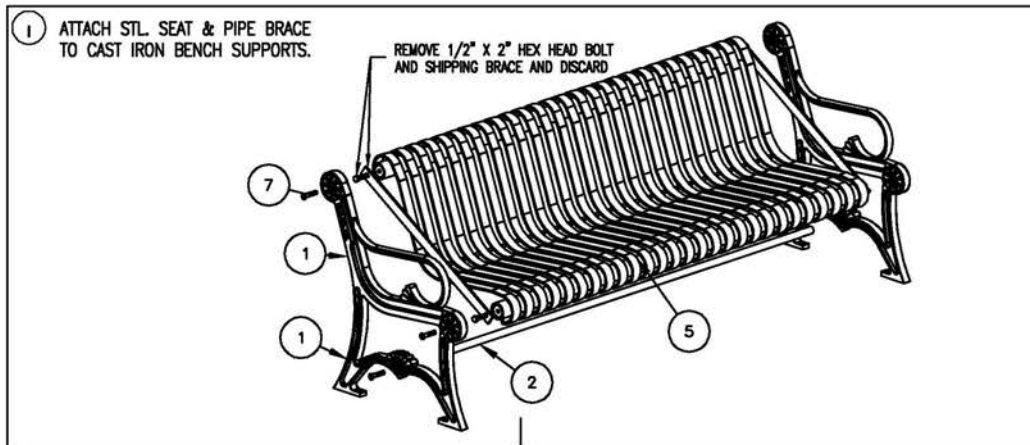

PARTS LIST			
ITEM	QTY	PART NO	DESCRIPTION
1	2	0-57-00-02	CAST IRON BENCH SUPPORT
2	1	0-57-60-04	71 3/4" PIPE BRACE
3	1	0-58-00AR-03	CAST IRON BOLT ON ARMREST
4	2	0-58-00AR-04	ARMREST BOLT CLIP MACHINED
5	1	0-58-60-01	6' STL SEAT
6	2	1-11-042	1/2" X 1 1/2" SS CGE BOLT
7	6	1-12-065	1/2" X 2 1/2" FLT SKT HD CAP SCR
8	2	1-20-015	1/2" SS NYLON LOCKNUT
9	2	1-22-015	1/2" SS FLAT WASHER
KITS PROVIDED			
ITEM	QTY	PART NO	DESCRIPTION
10	1	K-ANC0880-4	1/2" X 3 3/4" SS ANCHOR KIT (4PC)
11	1	K-CG0824-2L	1/2" CGE BOLT HARDWARE KIT (2PC)
12	1	K-FC0840-6	1/2" CAP HARDWARE KIT (6PC)

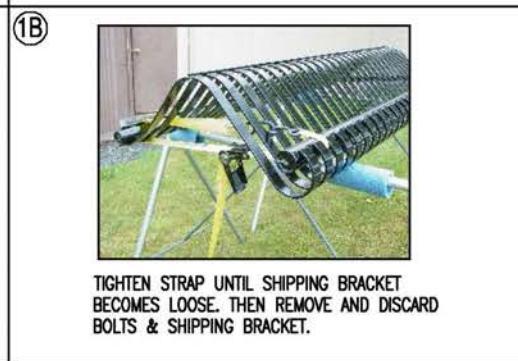

NOTES:

- 1.) DURING ASSEMBLY PROCEDURE; DO NOT COMPLETELY TIGHTEN HARDWARE.
- 2.) THE ACTUAL PARTS WILL NOT BE NUMBERED. NUMBERS ONLY APPLY TO DRAWING.
- 3.) UPON COMPLETION OF ASSEMBLY SQUARE ALL COMPONENTS THEN TIGHTEN ALL HARDWARE.
- 4.) MOUNT AND ANCHOR AS SPECIFIED.

TOOLS REQ'D

- 3/4" WRENCH
- 5/16" ALLEN WRENCH
- 1/2" MASONRY DRILL BIT
- DRILL
- RATCHET STRAP (PROVIDED)

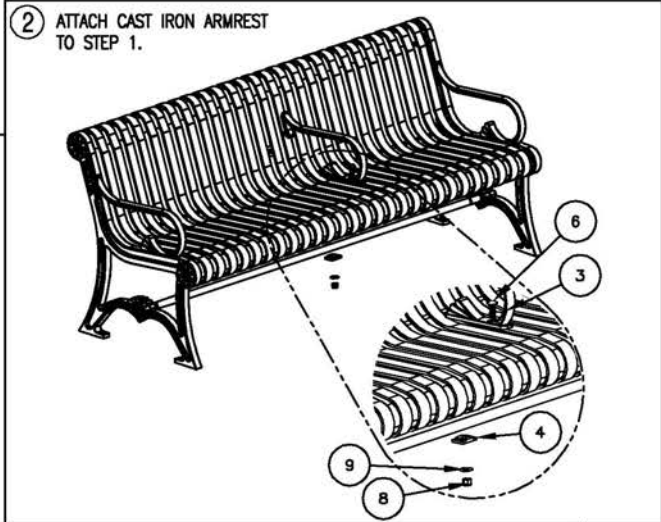

ASSEMBLY INSTRUCTIONS

DATE DRAWN : 11/21/99
 DRAWN BY : JSB
 DATE REV. : 00/00/00
 REV. BY : XXX

REV. A

DRAWING NUMBER

58 SER-3AR

SHEET 2 OF 2

Streetscape Elements

BICYCLE RACK

Description

Simple bike rack, located parallel to curb or building face and suitable for supporting two bicycles

Style

- Simple hoop, minimum 2 bike capacity

Size

- Approximately 1'-8" high (above grade)
- Approximately 1'-2" wide

Installation

- In ground mount embedded in concrete base

Materials and Color

- Powder-coated metal
- Black or 304 grade stainless steel finish

Location and Setbacks

- Parallel to wall: 24" minimum setback from wall, 36" recommended
- Parallel to curb: 36" minimum setback from face of curb

Requirements

- Dero Hoop Bicycle Rack or equal; embedded mounting

Sources

Dero
Hoop Bicycle Rack
52 Northern Stacks Drive
Minneapolis, MN 55421
www.dero.com

Landscape Forms, Inc.
Bolo Bicycle Rack, embedded mounting
431 Lawndale Ave.
Kalamazoo, MI 49048

The Park and Facilities
Catalog
www.parkcatalog.com

Belson Outdoors, LLC.
627 Amersale Dr.
Naperville, IL 60563

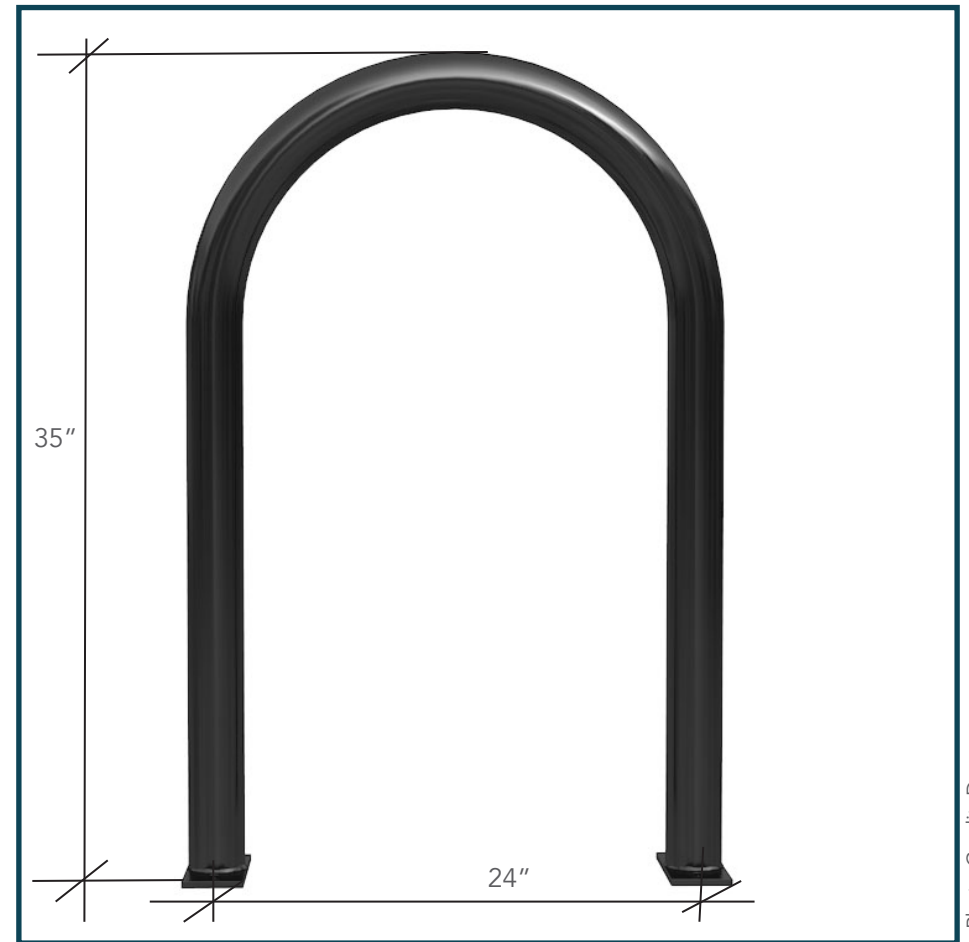

Bike rack

Photo Credit: Dero

Streetscape Elements

GUIDE SPECIFICATIONS FOR THE DERO HOOP BIKE RACK

SECTION 02871 BIKE RACKS

These specifications were current at the time of publication but are subject to change at any time without notice. Please confirm the accuracy of these specifications with the manufacturer and/or distributor prior to installation.

PART 1 GENERAL

1.1 Summary

- A. This section includes specifications for the Hoop Bike Rack.

- 1. Bikes parked per unit: 2

1.2 Quality Assurance

- A. Installer Qualifications: An experienced installer who has completed installation of bicycle racks similar in material, design, and extent to that indicated for this project and whose work has resulted in construction with a record of successful in-service performance.
- B. Manufacturer Qualifications: A firm experienced in manufacturing bicycle racks similar to those required for this project and with a record of successful in-service performance.
- C. Source Limitations: Obtain each color, finish, shape and type of bicycle rack from a single source with resources to provide components of consistent quality in appearance and physical properties.
- D. Product Options: Drawings indicate size, shape and dimensional requirements of bicycle racks and are based on the specific system indicated.

1.3 Submittals

- A. Product Data: Include physical characteristics such as shape, dimensions, bicycle, material parking capacity and finish for each bicycle rack.
- B. Shop Drawings: Show installation details for each bicycle rack.
- C. Samples for Verification: Submit finish samples for review and verification.
- D. Maintenance Data: For each bicycle rack.

- 1. Include recommended methods for repairing damage to the finish.

1.4 Delivery, Storage and Handling

- A. Upon delivery, before signing for shipment, inspect for any damages and notate on the B.O.L.
- B. Store bicycle racks in original undamaged packages and containers until ready for installation. Handle bicycle racks with sufficient care to prevent any scratches or damage to the finish.

PART 2 PRODUCTS

2.1 Acceptable Manufacturers

- A. Provide bicycle racks manufactured by DERO BIKE RACK CO., 42 Northern Stacks Drive, Suite 100, Minneapolis, MN 55421, 1-888-337-6729. Fax: 612-331-2731
Website: www.dero.com

2.2 Materials

- A. 1.5" schedule 40 uncoated pipe (1.90" OD)
- B. Installation Methods: In-ground mount is embedded into concrete base. Flange mount has two 2.5" x 6" x .25" feet - 4 anchors. In-ground mount, foot mount, and rail mount models are available.
- C. Rail Racks: Hoops are bolted to two parallel rails. Hoops can be left free standing or anchored to the ground. See Rail Racks section below. Rail material is AISI C3 x 4.1 steel channel.

2.3 Finishes

- A. A hot-dipped galvanized finish performed after fabrication is standard.
- B. Over 250 high quality TGIC powder-coated colors are available from Dero Bike Rack Co.
 - 1. A TGIC powder coat finish is available.
 - 2. For powder coated/ painted racks, the following specifications are required: Part is prepared for painting with hard sandblasting. An epoxy primer is electrostatically applied. A final TGIC, UV resistant polyester powder coat is applied. Final coating mil thickness shall be no less than 6 mils.
- C. A 304 grade stainless steel finish is also available. Either a satin #4 finish or high luster electropolish finish. Both finish options include the Spectra Shield finish for maximum corrosion protection.
- D. Six durable thermoplastic colors are available.
- E. A rubbery PVC dip is available in many colors. Black is standard.

2.4 Hoop Bike Rack

A. Setbacks

- 1. Wall Setback: For Hoops set parallel to the wall, a minimum of 24" should be left between the wall and the rack. 36" is the recommended setback. For Hoops installed perpendicular to the wall, a 28" setback is the minimum distance. 36" is recommended.
- 2. Distance Between Racks: 24" is the minimum distance between racks. 36" is recommended.
- 3. Street Setback: 24" is the minimum distance between the street and the rack. 36" is recommended.
- 4. The foot-mounted Hoop Rack has a 2.5" x 6" x .25" foot which is installed onto a concrete base with 4 masonry anchors. The foot-mounted Hoop Rack is generally less expensive to install and easier to remove than the in-ground mount model, while still maintaining the same degree of security.

C. Rail Racks

Streetscape Elements

1. Rail-mounted Hoops are standard foot-mounted Hoop Racks attached with bolts to a rail in the configurations from 3 to 7 Hoops. Rail racks provide more flexibility than mounted racks, but still provide the same degree of security.
2. Rail-mounted Hoops can be left either free-standing or can be anchored to the ground using several anchors. This portability allows for easy snow-removal or sweeping. It also means installation is much less expensive than imbedded bike racks.
3. The Advantages to rail-mounted racks are:
 1. Easier and inexpensive installation
 2. Can be left freestanding or anchored to the ground
 3. Can be easily removed
4. Rail Racks are commonly used where snow removal/sweeping is an issue, or when no suitable base material is available.

PART 3 EXECUTION

3.1 Installation

- A. Installation Method
 1. In ground mount
 2. Surface mount
 3. Rail-mounted (free standing)
 4. It is the responsibility of the installer to ensure that all base materials into which the rack will be installed can support the rack and will not be damaged by any required installation procedures.

3.2 Ordering Information

- A. When ordering or specifying this rack, make sure the product type, finish and fastener type (if applicable) are included. Contact your Dero representative for a current price list or to place an order.
- B. Included in the price is either a hot-dipped galvanized finish, a TGIC powder coat finish, or a stainless steel finish. The foot-mounted and Rail Rack Hoops include 4 wedge anchors or concrete spikes.

3.3 Freight

- A. Call 1-888-337-6729 for freight quotes.

Streetscape Elements

BOLLARD/BARRIER

Description

Simple cylindrical formed bollard to be used for pedestrian protection and for defining edges between vehicles and pedestrians

Style

- Straight, simple
- Permanent or removable options

Size

- 37" height
- 4 1/2" diameter

Materials and Color

- Powder-coated metal
- Black or 304 grade stainless steel finish

Location and Setbacks

- Minimum 18" setback from face of curb if posted speed limit is 25 MPH and curb is VDOT Standard Details CG-2 or CG-6
- If curb and/or speed do not meet the above specification, it must meet the VDOT clear zone requirements or pass current crash test requirements for obstacles within street clear zones

Requirements

- Keystone Ridge Grove bollard, GVE-4 or equal

Sources

Keystone Ridge Designs, Inc.
670 Mercer Road
Butler, PA 16001
www.keystoneridgedesigns.com

Victor Stanley
PO Drawer 330
Dunkirk, MD 20754
www.victorstanley.com

Reliance Foundry
Unit 207
6450-148th St.
Surrey, British Columbia
Canada V3S-7G7
www.reliance-foundry.com



Photo Credit: Keystone Ridge

Bollard

Streetscape Elements



Grove Bollard

Exclusive By Design™

32 39 13 Manufactured Metal Bollards
12 93 13 Bicycle Racks



PART 1 – GENERAL

- 1.1 DESCRIPTION
 - A. Section includes: Manufactured Metal Bollards and Bicycle Racks
- 1.2 SUBMITTALS
 - A. Comply with Section 01 33 00 – Submittal Procedures
 - B. Product Data – submit the following information:
 1. Product literature
 2. CAD drawings
 3. Made in the USA Statement
 4. Proprietary information
 - C. Samples – submit manufacturer’s color sample, standard or custom
 - D. Warranty – submit manufacturer’s standard warranty
- 1.3 QUALITY ASSURANCE
 - A. Manufacturer’s Qualifications: Manufacturer nationally-recognized, patented designer and manufacturer of quality site amenities since 1995
 - B. References: Provide references of previous public-use purchasers of manufacturer’s site furniture
- 1.4 DELIVERY, STORAGE AND HANDLING
 - A. Delivery: Deliver products to site in manufacturer’s clearly-marked original, unopened containers and packaging. Upon delivery, examine packages immediately to ensure all products are complete and undamaged.
 - B. Storage: Store products in a protected, dry area in manufacturer’s unopened containers and packaging until installation.
 - C. Handling: Protect product’s finish from damage during handling and installation.
- 1.5 WARRANTY
 - A. Material is warranted against material and workmanship defects for THREE YEARS from the date of shipment from manufacturer, assuming products are installed and maintained according to manufacturer’s instruction.
 - B. Products damaged by abnormal use, vandalism or acts of nature are not eligible for this factory warranty.
 - C. Manufacturer will repair or replace any part found defective upon written notification and inspection by our manufacturer’s representative.



KEYSTONE RIDGE DESIGNS, INC.®
670 MERCER ROAD
BUTLER, PA 16001
1-800-284-8208
FAX: (724) 284-1253
www.keystoneridgedesigns.com

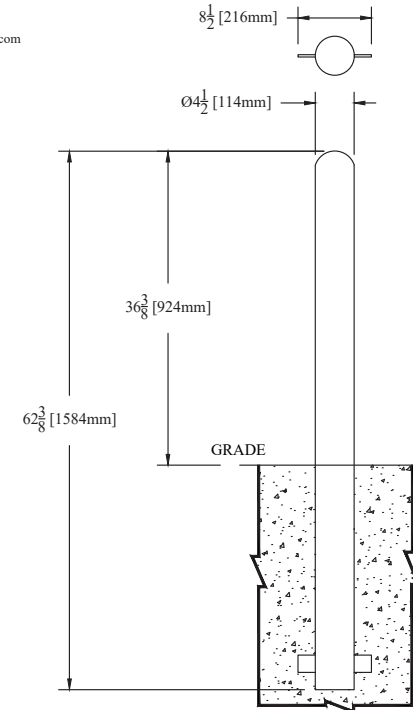

SPECIFICATIONS		EXCLUSIVE BY DESIGN™
STEEL SIZES 4" SCH 40 PIPE STEEL CAP 1/4" x 2" FLAT		
STEEL FINISH KEYSHIELD® POWDER COATING		GROVE PERMANENT BOLLARD
HARDWARE ANCHOR BOLTS NOT INCLUDED		ELEVATION - PLAN
DRAWN BY: B.R.		THIS DOCUMENT AND ALL INFORMATION SHOWN HEREON ARE THE EXCLUSIVE PROPERTY OF KEYSTONE RIDGE DESIGNS, INC.® THIS DOCUMENT IS FURNISHED WITH THE EXPRESS UNDERSTANDING THAT NEITHER IT NOR THE INFORMATION ON IT IS TO BE DISCLOSED OR REPRODUCED IN WHOLE OR IN PART, OR USED IN ANY WAY, EITHER DIRECTLY OR INDIRECTLY, FOR THE BENEFIT OF ANYONE OTHER THAN KEYSTONE RIDGE DESIGNS, INC.® WITHOUT ITS WRITTEN CONSENT.
DATE: 07-16-12		
		GVE-4

Streetscape Elements



Grove Bollard

Exclusive By Design™

32 39 13 Manufactured Metal Bollards
12 93 13 Bicycle Racks

PART 2 - PRODUCTS

2.1 MANUFACTURER

Keystone Ridge Designs, Inc.
670 Mercer Road · Butler, PA 16001 USA
Toll Free: (800) 284-8208
Phone: (724) 284-1213 · Fax: (724) 284-1253
E-mail: sales@krdusa.com
Web: <http://keystoneridgedesigns.com>

2.2 BOLLARD

- A. Product Name: Grove bollard
- B. Product Definition: Exclusive By Design™ fully-assembled metal powder coated bollard; made in the USA; complete weld seams where two pieces of steel touch to reduce chance of corrosion
- C. Type/Part Number
 - a. Grove straight permanent: GVE-4
 - b. Grove straight removable: GVR-4
 - c. Grove one loop permanent: GV1E-4
 - d. Grove one loop removable: GV1R-4
 - e. Grove two loop permanent: GV2E-4
 - f. Grove two loop removable: GV2R-4
 - g. Grove one chain permanent: GV1CE-4
 - h. Grove one chain removable: GV1CR-4
 - i. Grove two chain permanent: GV2CE-4
 - j. Grove two chain removable: GV2CR-4
- D. Metal pieces powder coated in standard colors as listed in current annual catalog

2.3 MATERIALS

- A. Commercial-grade materials, at least 25% recycled raw steel, 100% recyclable steel; completely welded for optimum strength and stability; sizes and dimensions according to Keystone Ridge Designs, Inc. CAD drawing; 4" schedule 40 pipe with half dome cap; 11 ga x 3-3/4" tubing removable sleeve; 1/4 x 2" flat steel tabs for concrete stabilization or locking attachment; 1" schedule 40 pipe for loops and 1/2" cast iron d-rings for chain loops

2.5 FINISHES

- A. Metal: The KEYSHIELD® finish protects each piece of furniture from chipping, cracking, UVA damage and provides unparalleled corrosion resistance. Steel products are finished with a two-coat powder coating process applied to a 7-15 mil thickness. Substrate preparation includes sandblasting to a white finish to remove all surface contaminants, the ultimate degree in powder coat preparation. The raw product then receives a corrosion-inhibiting phosphate coating prior to the application of the powder coating. The first coat applied to the substrate is zinc rich epoxy powder primer used exclusively on sandblasted parts. The second coat is a colored polyester powder coating. Both coats are electrostatically applied and oven cured according to powder coating manufacturing specifications to create a smooth, satin-like finish.

2.6 MANUFACTURER EXPERTISE

- A. Trained consultants provide expertise on product specifications, technical inquiries and project timelines directly from the manufacturing home office.



Grove Bollard

Exclusive By Design™

32 39 13 Manufactured Metal Bollards
12 93 13 Bicycle Racks

PART 3 - EXECUTION

3.1 EXAMINATION

- A. Confirm that installation area is as defined by architect and safe for product placement.

3.2 INSTALLATION

- A. Install product in accordance with manufacturer's instructions at locations indicated on the drawings.
- B. Install product level and plumb.
- C. Anchor product securely in place. If required, use 3/8" diameter stainless steel anchor bolt no shorter than 6" in length; do not over-tighten.

3.3 PROTECTION

- A. Protect products prior to installation by having them remain in the manufacturer's packaging and container.

Streetscape Elements

CYCLE STALL

Description

Bicycle rack, combined into groups of 10 for installation in on-street parking space, parking garage, or surface lot for multiple bike storage spaces

Style

- Simple hoop, minimum 10 bike capacity

Size

Individual Hoop

- Approximately 1'-8" high (above grade)
- Approximately 1'-2" wide

Frame

- 18 feet by 113 inches for 10 bike capacity (five hoops)

Installation

- In-ground mount embedded in concrete base

Materials and Color

- Powder-coated metal
- Black or 304 grade stainless steel finish

Location and Setbacks

- Parallel to curb: 44" minimum setback from face of curb

Requirements

- Dero Hoop Bicycle Rack or equal; embedded mounting

Sources

Dero
Hoop Bicycle Rack
52 Northern Stacks Drive
Minneapolis, MN 55421
www.dero.com

Landscape Forms, Inc.
Bolo Bicycle Rack, embedded
mounting
431 Lawndale Ave.
Kalamazoo, MI 49048

Belson Outdoors, LLC.
627 Amersale Dr.
Naperville, IL 60563

The Park and Facilities Catalog
www.parkcatalog.com



Cycle stall/bike rack for multiple bike parking

Photo Credit: Dero

Streetscape Elements

CYCLE STALL BASIC

Setbacks

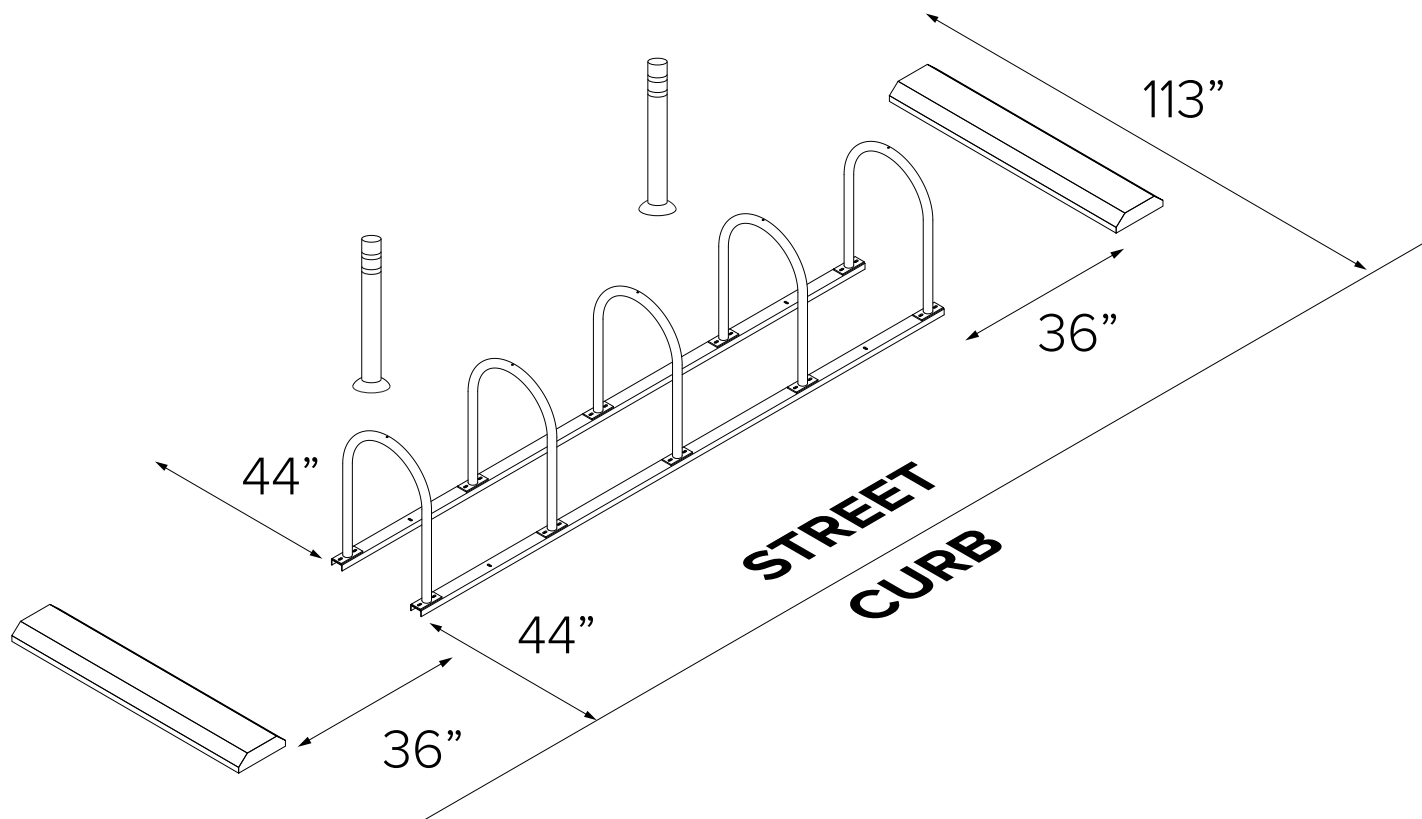

Streetscape Elements

CYCLE STALL BASIC Submittal Sheet

Traffic delineators are included in either yellow (standard) or white color options.

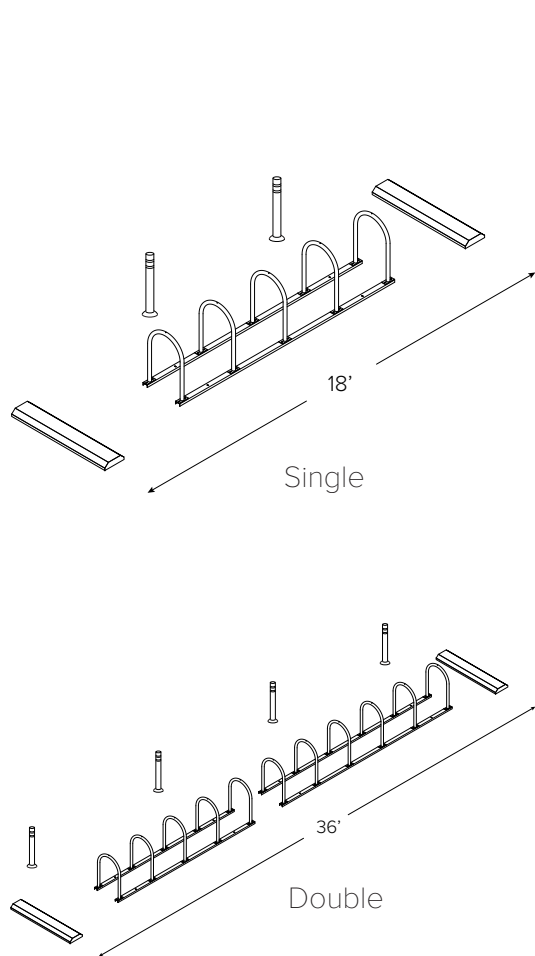

CAPACITY

Single: 10 Bikes
Double: 22 Bikes

MATERIALS

Hoop Racks: 1.5" schedule 40 pipe (1.9" OD)
Wheel Stops: Recycled plastic

FINISHES

- Galvanized**
An after fabrication hot dipped galvanized finish is our standard option.
- Powder Coat**
Our powder coat finish assures a high level of adhesion and durability by following these steps:
 1. Sandblast
 2. Epoxy primer electrostatically applied
 3. Final thick TGIC polyester powder coat
- Thermoplastic Coating**
In addition to an increased thickness (8-10mils), the thermoplastic finish covers a galvanized layer and offers superior impact resistance over powder coating.
- Stainless**
Stainless Steel: 304 grade stainless steel material finished in either a high polished shine or a satin finish.

MOUNT OPTIONS

- Rail**
Rail Mounted Racks are bolted to two parallel rails which can be left freestanding or anchored to the ground. Rails are heavy duty 3"x1.4"x3/16" thick galvanized mounting rails. Specify rail mount for this option.

Streetscape Elements

DRINKING FOUNTAIN

Description

Barrier free drinking fountain with pet station, to match fountain located in Old Town Square

Style

- Elkay Outdoor Fountain Bi-Level Pedestal with Pet Station, Non-Filtered Non-Refrigerated, Freeze Resistant, Black
- LK4420DBFRKBLK

Size

- L: 14"
- W: 31"
- H: 40-5/16"

Materials and Color

- Powder-coated exterior over a corrosion-resistant stainless steel type-316 base material to provide protection from the elements.
- Black color

Location and Setbacks

- Sidewalk, minimum of 6' from curb and outside of Pedestrian Zone

Requirements

- Elkay Outdoor Fountain as referenced here or equal

Source

Elkay
2222 Camden Court
Oak Brook, IL 60523
Phone: 630-574-8484
<http://www.elkay.com/>



Drinking Fountain, installed in Old Town Square

Photo Credit: Elkay

Streetscape Elements

ELKAY SPECIFICATIONS

Elkay Outdoor Fountain Bi-Level Pedestal with Pet Station Non-Filtered Non-Refrigerated Freeze Resistant Model LK4420DBFRK

PRODUCT SPECIFICATIONS

Elkay Outdoor Fountain Bi-Level Pedestal with Pet Station, Non-Filtered Non-Refrigerated, Freeze Resistant. Features shall include 316 Stainless, Heavy Duty Vandal-Resistant, Pet Fountain, Sealed Freeze Resistant. Furnished with Vandal-Resistant bubbler. Mechanical Front Bubbler Button activation. Product shall be Floor Mount/Freestanding, for Outdoor applications, serving 2 station(s). Unit shall be lead-free design which is certified to NSF/ANSI 61 & 372 (lead free) and meets Federal and State low-lead requirements.

Special Features:	316 Stainless, Heavy Duty Vandal-Resistant, Pet Fountain, Sealed Freeze Resistant
Finish:	Beige (BGE), Black (BLK), Blue (BLU), Brown (BRN), Evergreen (EVG), Gray (GRY), Orange (ORN), Purple (PUR), Red (RED), Terracotta (TER), White (WHT), Yellow (YLW)
Power:	No Electrical Required
Bubbler Style:	Vandal-Resistant
Activation by:	Mechanical Front Bubbler Button
Mounting Type:	Floor Mount/Freestanding
Chilling Option:	Non-Refrigerated
Dimensions (L x W x H):	14" x 31" x 40-5/16"
Approx. Shipping Weight:	170 lbs.
Installation Location:	Outdoor
No. of Stations Served:	2



AMERICAN PRIDE. A LIFETIME TRADITION. Like your family, the Elkay family has values and traditions that endure. For almost a century, Elkay has been a family-owned and operated company, providing thousands of jobs that support our families and communities.



PRODUCT COMPLIANCE
ADA & ICC A117.1
Buy American Act
NSF/ANSI 61 & 372 (lead free)



Complies with ADA & ICC A117.1 accessibility requirements when installed according to the requirements outlined in these standards. Installation may require additional components and/or construction features to be fully compliant. Consult the local Authority Having Jurisdiction if necessary.

[Installation Instructions \(PDF\)](#)

Warranty pertains to drinking water applications only. Non-drinking water applications are not covered under warranty.

[Warranty \(PDF\)](#)

OPTIONAL ACCESSORIES

LK4471LHB - Locking Hose Bib
97890C - Accessory - Direct Bury Adaptor

PART: _____ QTY: _____
PROJECT: _____
CONTACT: _____
DATE: _____
NOTES: _____
APPROVAL: _____

In keeping with our policy of continuing product improvement, Elkay reserves the right to change product specifications without notice. Please visit elkay.com for the most current version of Elkay product specification sheets. This specification describes an Elkay product with design, quality, and functional benefits to the user. When making a comparison of other producers' offerings, be certain these features are not overlooked.

Elkay REV 05082018
LK4420DBFRK

2222 Camden Court
Oak Brook, IL 60523

© 2018 Page 1
LK4420DBFRK_spec.pdf

ELKAY SPECIFICATIONS

Elkay Outdoor Fountain Bi-Level Pedestal with Pet Station Non-Filtered Non-Refrigerated Freeze Resistant Model LK4420DBFRK

MOUNTING INSTRUCTIONS and PLUMBING INSTRUCTIONS

Site and drainage excavation is required for fountain installation. Refer to owner's manual for site preparation details. Provide solid, well-drained surface to mount pedestal fountain (concrete pad recommended) with adequate support (300 lb. load minimum). (6) 3/8" minimum fasteners (not included) should be attached securely to mounting surface in order to secure fountain. (Refer to rough-in diagram), and be sure to allow an opening for the freeze-resistant valve in the ground as shown in the installation instructions that accompany the fountain. (Refer to the rough-in diagram below). Refer to local codes for any additional requirements.

Locate and install plumbing through ground as required. Assemble fountain to prepared site and mounting pad.

NOTE: Fountain is not furnished with service valve. Position pedestal over plumbing and secure base to fasteners. Remove access panels and connect supply and water lines. Turn on water supply and check for leaks. Refer to owner's manual for detailed instructions. Reassemble access panels to pedestal. Trap and service stop not included.

SANITARY FREEZE-RESISTANT VALVE GROUND INSTALL DETAIL

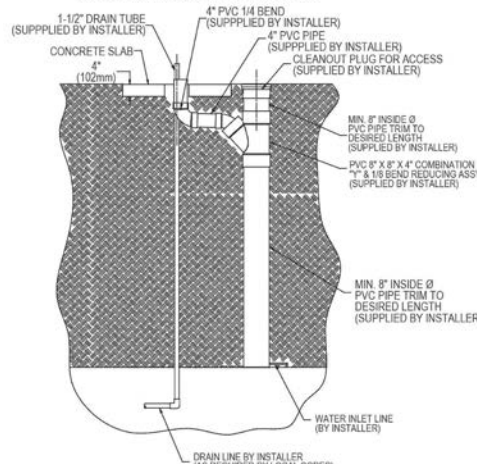

OPERATING PRESSURES:
Supply water 20 - 100 psi maximum

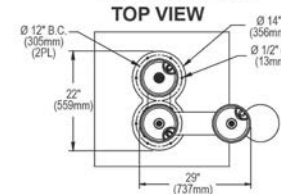

DETAIL A

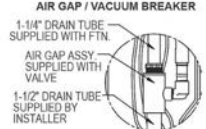

SIDE VIEW

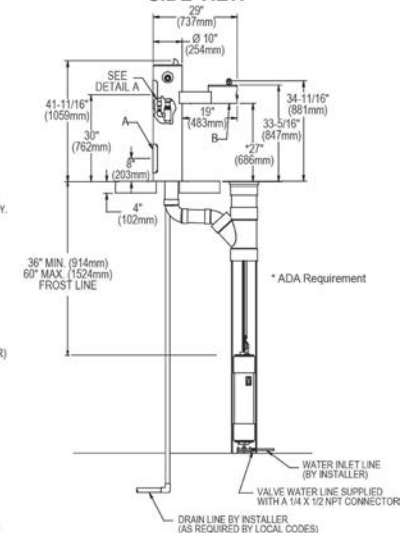

In keeping with our policy of continuing product improvement, Elkay reserves the right to change product specifications without notice. Please visit elkay.com for the most current version of Elkay product specification sheets. This specification describes an Elkay product with design, quality, and functional benefits to the user. When making a comparison of other producers' offerings, be certain these features are not overlooked.

Elkay REV 05082018
LK4420DBFRK

2222 Camden Court
Oak Brook, IL 60523

© 2018 Page 2
LK4420DBFRK_spec.pdf

Streetscape Elements

PLANTER - HANGING BASKET

Description

Metal basket hung parallel to the curbline

Style

- Circular, traditional

Size

- 30" diameter with 12.5" depth

Materials and Color

- Powder coated black iron basket
- Heavy gauge steel chains
- Coconut coir liner

Location and Setbacks

- Hanging basket must maintain a 7 foot vertical clearance from the pavement surface to the basket base when basket extends in Pedestrian Zone and a 15 foot vertical clearance when basket extends into the Roadway Zone
- Hanging baskets may be extended perpendicular to the banner arm if the 7 foot vertical clearance is maintained within the Pedestrian Zone

Irrigation Options

- Reservoir
- Run irrigation line on outside surface of pedestrian light pole

Requirements

- Planters Unlimited/ Hooks & Lattice steel basket B-HB-XL-30 or equal
- Planters Unlimited/ Hooks & Lattice WW-100-HB-22 coconut coir liner or equal

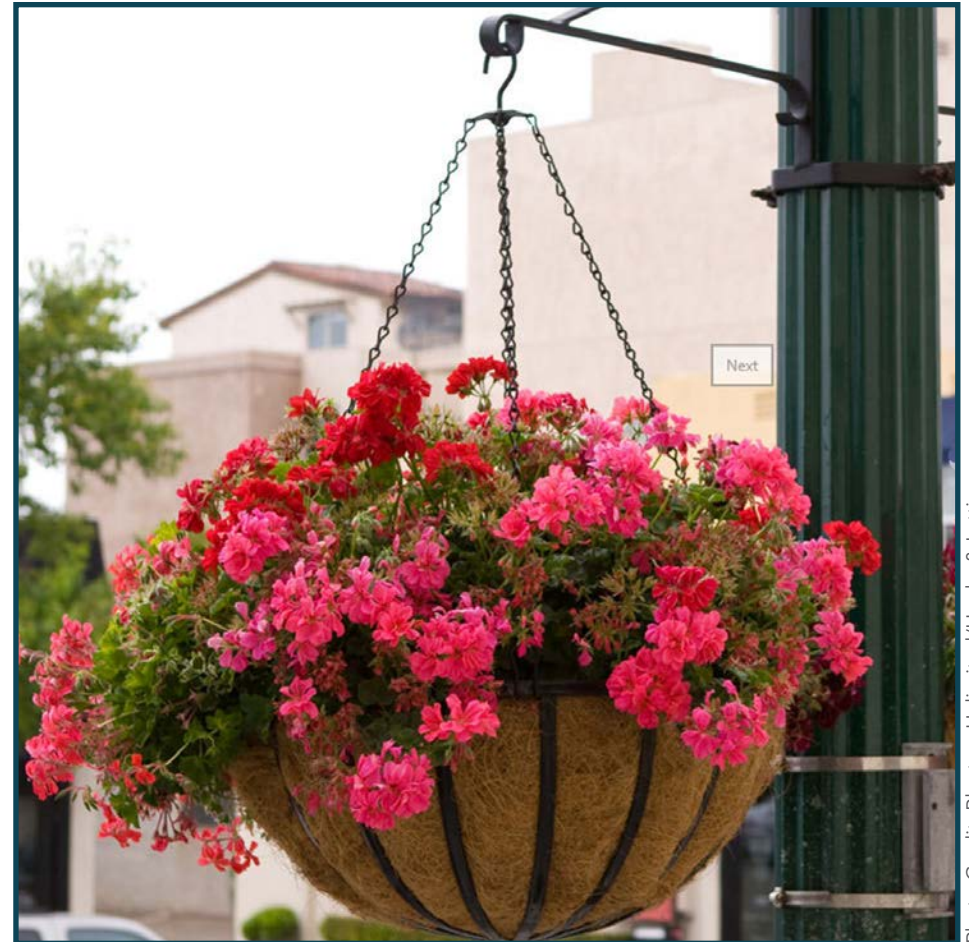

Photo Credit: Planters Unlimited/Hooks & Lattice

Hanging basket

Sources

Planters Unlimited/Hooks & Lattice
6056 Corte Del Cedro
Carlsbad, CA 92011
www.hooksandlattice.com

Tournesol Siteworks, LLC.
2930 Faber St.
Union City, CA 94587
www.tournesolsiteworks.com

Streetscape Elements



PLANTERS UNLIMITED
 6056 CORTE DEL CEDRO
 CARLSBAD, CA 92011
 TOLL FREE: (888) 320-0626
 PHONE: (760) 707-5400
 FAX: (760) 603-0812
 www.plantersunlimited.com

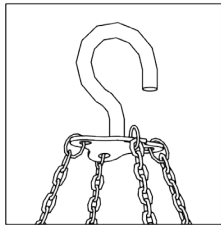

TOP MOUNT DETAIL

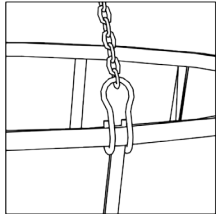

BASKET ATTACHMENT DETAIL

BASKET PART #: B-HB-XL-30
 LINER PART #: B-HBL-XL-30

NOTES:

1. DRAWINGS NOT TO SCALE.
2. POWDER-COATED BLACK IRON

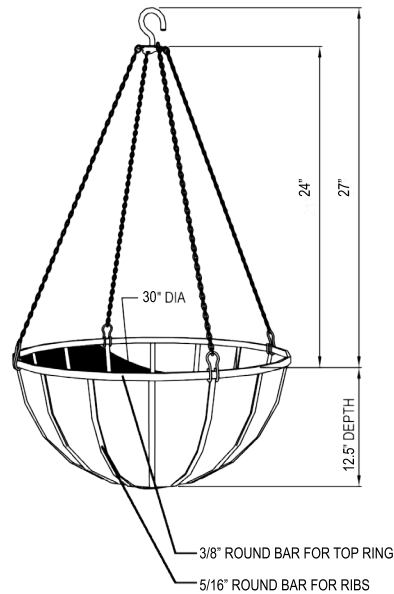

Hanging basket reservoir

Note: reservoir pictured may only be available for 22" Hanging Basket and is not available for Haybasket



HANGING BASKET PLANTER

30" DIAMETER WITH COCONUT COIR LINER

Photo Credit: Planters Unlimited/Hooks & Lattice

Streetscape Elements

PLANTER - HAYRACK BASKET

Description

Metal basket encircling the pedestrian light pole

Style

- Lamppost Hayrack basket LPH25, encircles pole

Size

- 26" overall diameter with 14" depth and 12" front to back
- Pole diameter can range from 4" to 7"

Materials and Color

- Heavy gauge steel bars coated in black plastic
- Coconut coir liner for LPH25 Lamppost Hayrack

Location and Setbacks

- Hayrack basket must maintain a 7 foot vertical clearance from the pavement surface to the basket base when basket extends in Pedestrian Zone and a 15 foot vertical clearance when basket extends into the Roadway Zone

Irrigation Options

- Not currently available with this planter basket

Requirements

Garden Artisans hayrack basket or equal

Source

Garden Artisans
Phone: (410) 824-1891
Fax: (410) 280-2184
451 Defense Highway, Ste A
Annapolis, MD 21401
<https://gardenartisans.com>



Hayrack basket

Streetscape Elements

Overall Diameter: 26"
Overall Depth: 14"

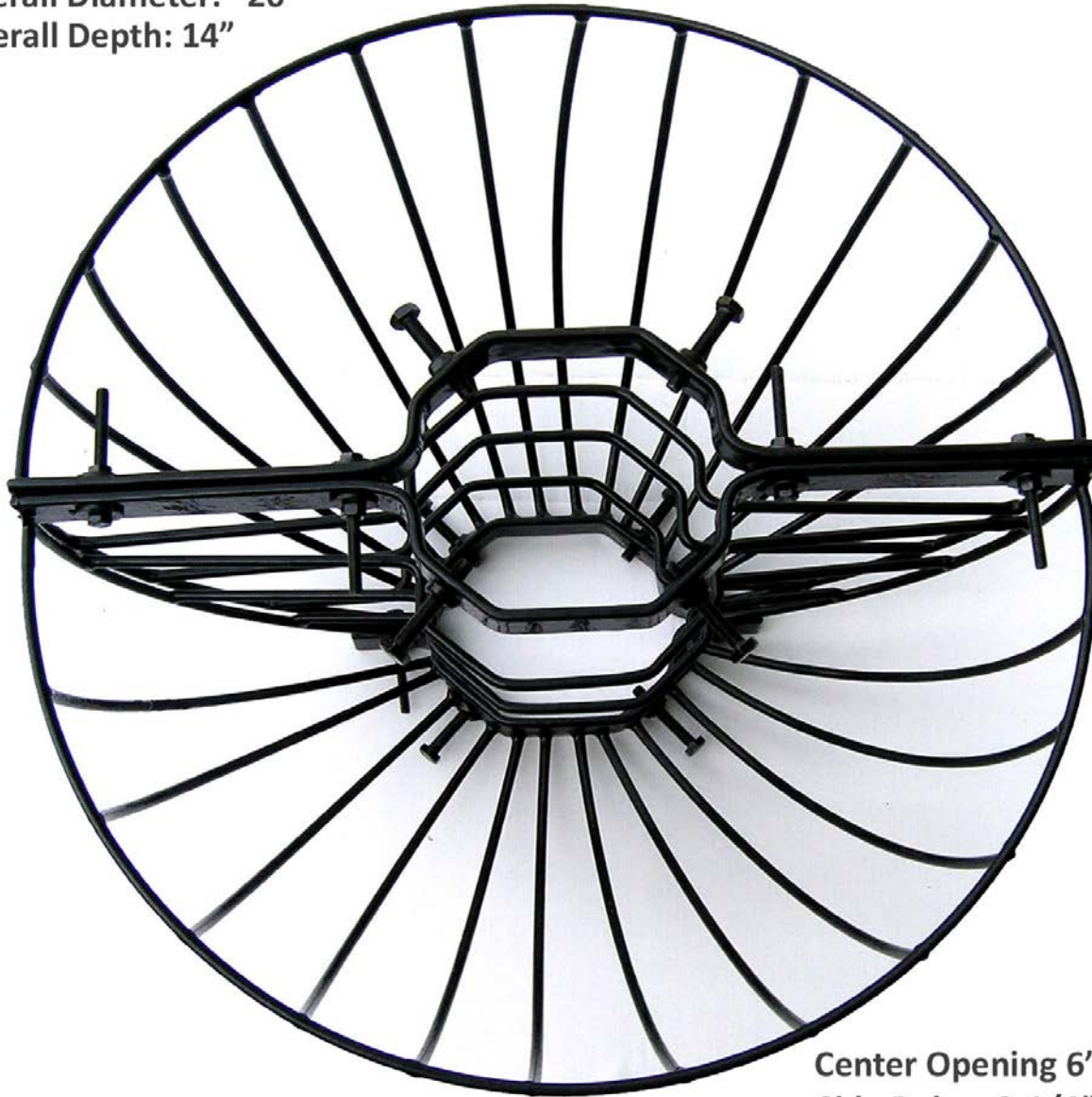

Center Opening 6"
Side Bolts: 3-1/4" Long
Center Bolts: 2-1/2" Long

Streetscape Elements

PLANTER - POT

Description

Planter pots with seasonal plantings provide color throughout the HOD, and are of particular value where space is limited for ground level installation of trees and shrubs.

Style

- Simple, round
- Includes drain hole

Size

- 36" diameter and 23" height
- 30" diameter and 18" height
- 24" diameter and 15" height

Installation

- Freestanding

Materials and Color

- Lightweight polyethylene (LMPDE)
- Black or fog

Location and Setbacks

- Pots located adjacent to streets with greater than 25 MPH posted speed limit roadway and/or curb other than VDOT Standard Details CG-2 or CG-6 to follow VDOT standards for clear zone
- Minimum 1.5' clear setback from face of curb on streets with posted 25 MPH speed limit and VDOT Standard Details CG-2 or CG-6 curbs

Requirements

- Landscape Forms Rosa Planter, freestanding with drain hole or equal
- Optional Reservoir equal to Tournesol Siteworks CWM Modular Container Irrigation, CWM-1720-3k



Photo Credit: Landscape Forms

Planter pots

Sources

Preferred Source
Landscape Forms, Inc.
7800 E. Michigan Ave.
Kalamazoo, MI 49048
www.landscapeforms.com

Tournesol Siteworks, LLC.
2930 Faber St.
Union City, CA 94587
www.tournesolsiteworks.com

Victor Stanley
PO Drawer 330
Dunkirk, MD 20754
www.victorstanley.com

Streetscape Elements

Rosa™ Planter, 36in Dia X 23in H, Freestanding, with Drain Hole
Product Drawing

Date: 5/14/2010
www.landscapeforms.com Ph: 800.521.2546

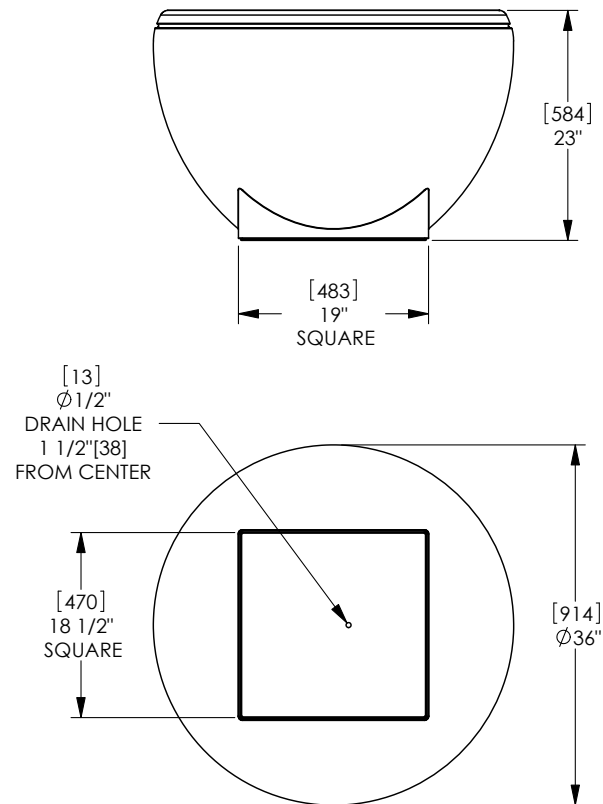

NOTE:

1. This drawing illustrates the 36" x 23" sized planter. Other sizes are available and acceptable for use as noted.

landscapeforms®

Drawing: RO409-02
Dimensions are in inches [mm]
U.S. Patent No.: D408,322

CONFIDENTIAL DRAWING INFORMATION CONTAINED HEREIN IS THE PROPERTY OF LANDSCAPE FORMS, INC. INTENDED USE IS LIMITED TO DESIGN PROFESSIONALS SPECIFYING LANDSCAPE FORMS, INC. PRODUCTS AND THEIR DIRECT CLIENTS. DRAWING IS NOT TO BE COPIED OR DISCLOSED TO OTHERS WITHOUT THE CONSENT OF LANDSCAPE FORMS, INC. © 2013 LANDSCAPE FORMS, INC. ALL RIGHTS RESERVED.

Streetscape Elements

TRASH CAN

Description

Trash can - black in color; style to match Old Town Square can or City Park can
Recycling can - blue in color; style to match Old Town Square can or City Park can

Style

- Side opening
- Logo banding optional

Size

- 24" diameter
- 39" height
- 36 gallon side-opening, stainless steel hinge and latch, surface mounted

Materials and Color

- Cast aluminum, spun aluminum top
- Cast iron base
- Stainless steel fasteners
- Matte Black for trash; blue for recycling
- Polyester powder-coat

Location and Setbacks

- Minimum 24 inches setback from face of curb
- Do not exceed 1 receptacle (or 2 if waste/recycling combination) per 300 linear feet (LF) of streetscape

Requirements

- Landscape Forms Chase Park Litter and Recycling Receptacles or equal
- Global Industries Outdoor Steel with Rain lid or equal

Sources

Landscape Forms, Inc.
7800 E. Michigan Ave.
Kalamazoo, MI 49048
www.landscapeforms.com

Keystone Ridge Designs, Inc.
670 Mercer Road
Butler, PA 16001
www.keystoneridgedesigns.com

Victor Stanley
PO Drawer 330
Dunkirk, MD 20754
www.victorstanley.com

Global Industrial
1.888.978.7759
www.globalindustrial.com



City of Fairfax trash can at Old Town Square, left and recycling trash can from City Park, right

Streetscape Elements

Chase Park®

Side Opening Litter Receptacle, Dual use, with sand pan, logo band, lock, 2 standard 5x7 signs

Date: 7/17/2014

Product Drawing

www.landscapeforms.com

Ph: 800.521.2546

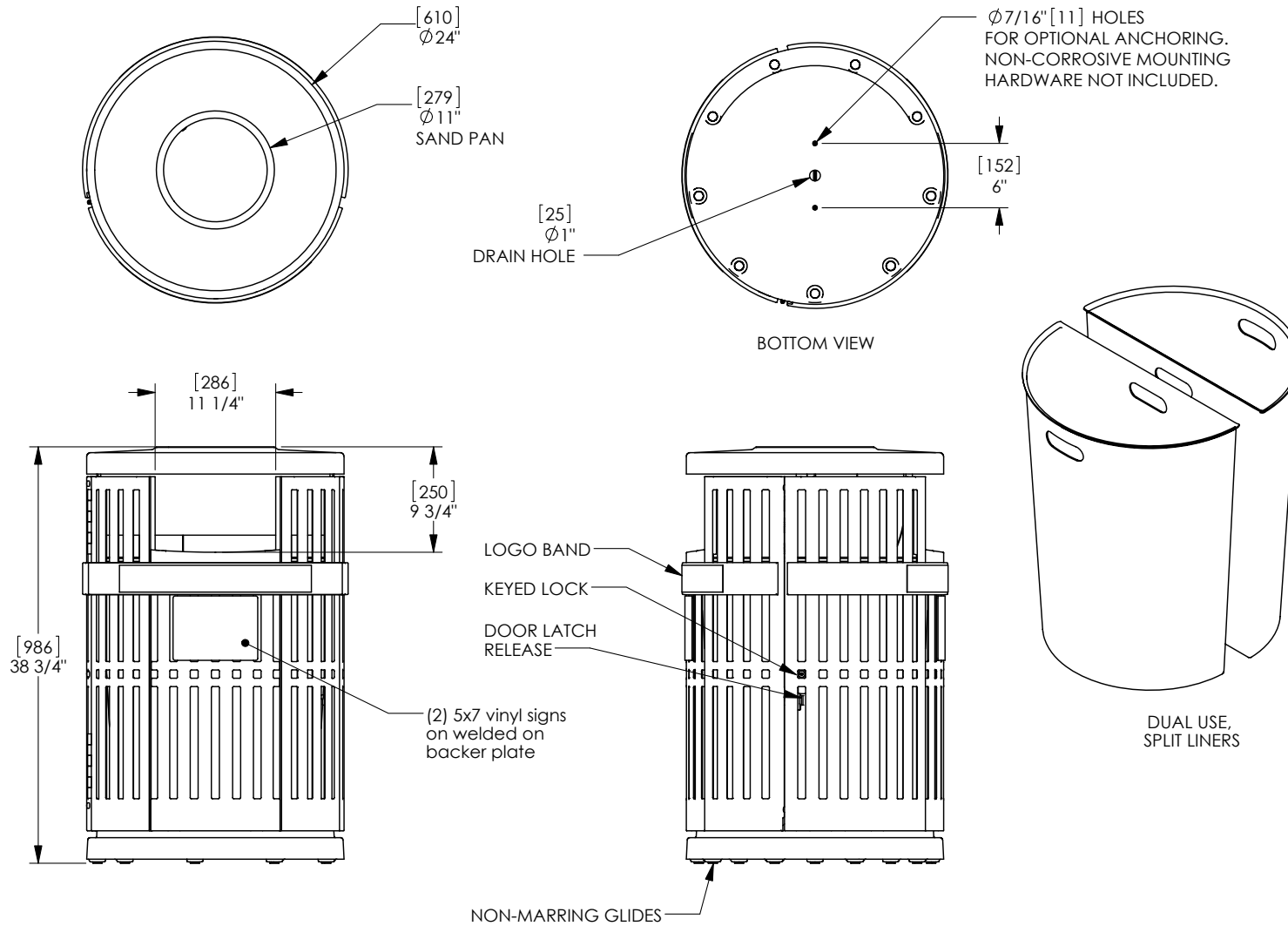

Drawing: CP362-16
 Dimensions are in inches [mm]
 U.S. Patent Nos.: D472,357; D481,507; D489,502

CONFIDENTIAL DRAWING INFORMATION CONTAINED HEREIN IS THE PROPERTY OF LANDSCAPE FORMS, INC. INTENDED USE IS LIMITED TO DESIGN PROFESSIONALS SPECIFYING LANDSCAPE FORMS, INC. PRODUCTS AND THEIR DIRECT CLIENTS. DRAWING IS NOT TO BE COPIED OR DISCLOSED TO OTHERS WITHOUT THE CONSENT OF LANDSCAPE FORMS, INC. © 2013 LANDSCAPE FORMS, INC. ALL RIGHTS RESERVED.

Streetscape Elements

TREE GRATE

Description

Steel grate that meets ADA standards and provides protection for street tree roots

Style

- Recycled iron grate

Size

- 48" square or to fit opening

Materials and Color

- Recycled iron top
- Steel angle frame
- Concrete anchors for paver installation
- Powdercoat - Matte Black

Location and Setbacks

- Shape sized to fit tree pit opening

Requirements

- Ironsmith Starburst 1 or equal

Source

Ironsmith
41701 Corporate Way #3
Palm Desert, CA 92260
800-338-4766
www.ironsmith.biz

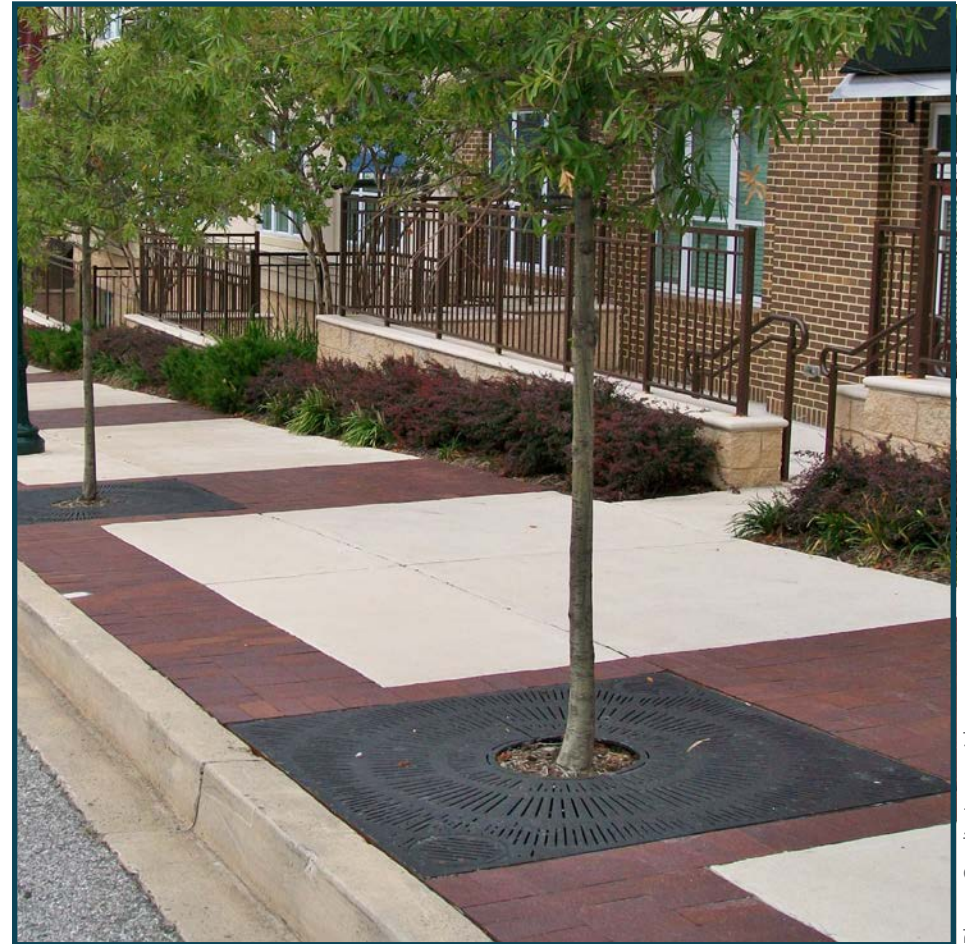
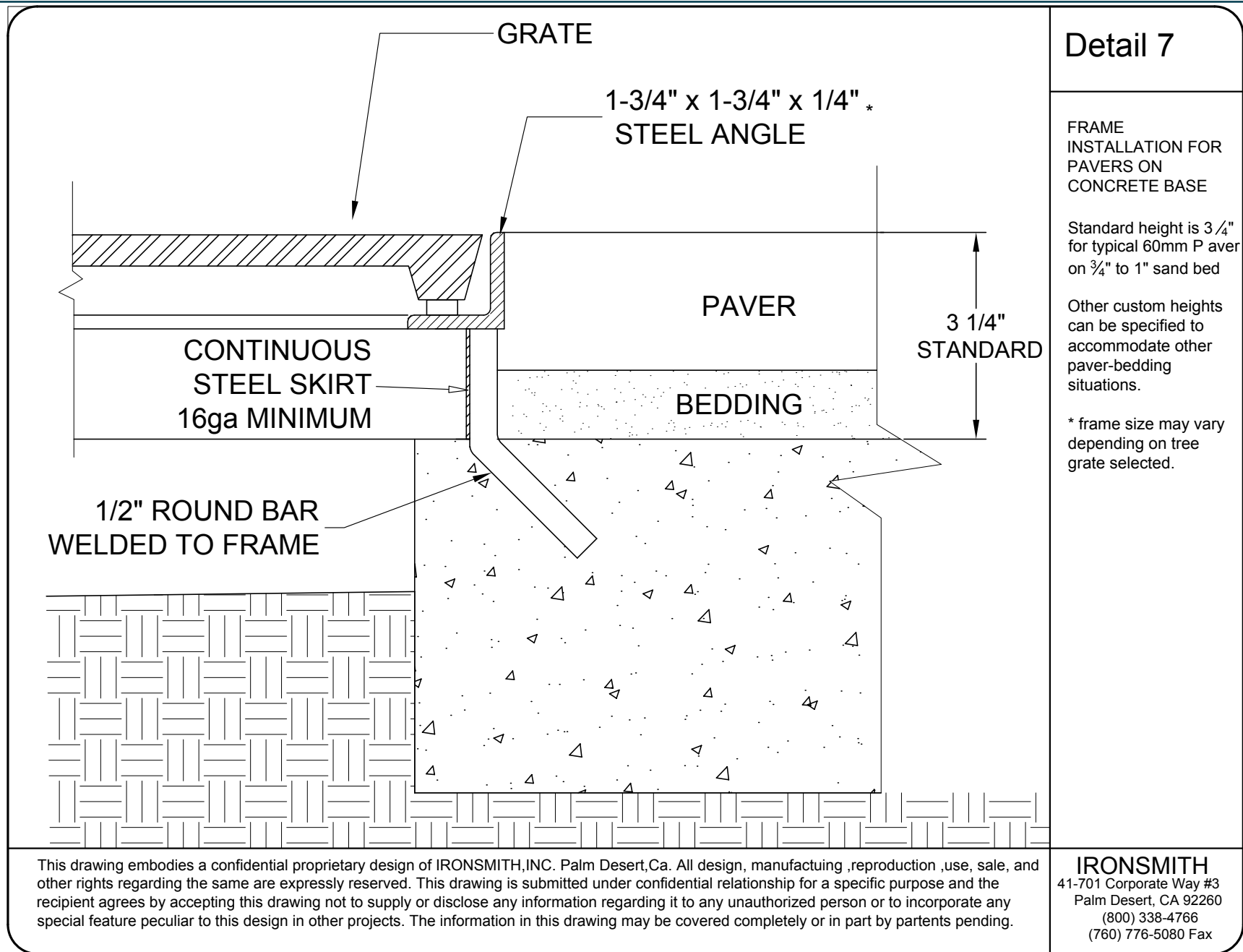

Photo Credit: Ironsmith

Street tree grate

Streetscape Elements



Streetscape Elements

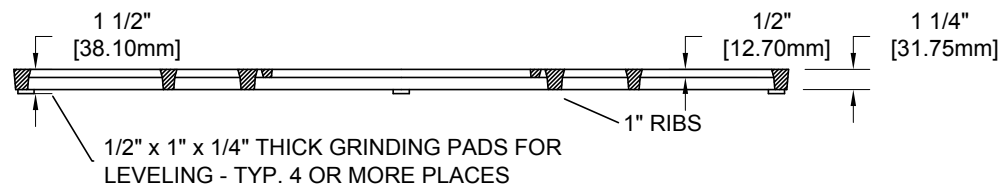
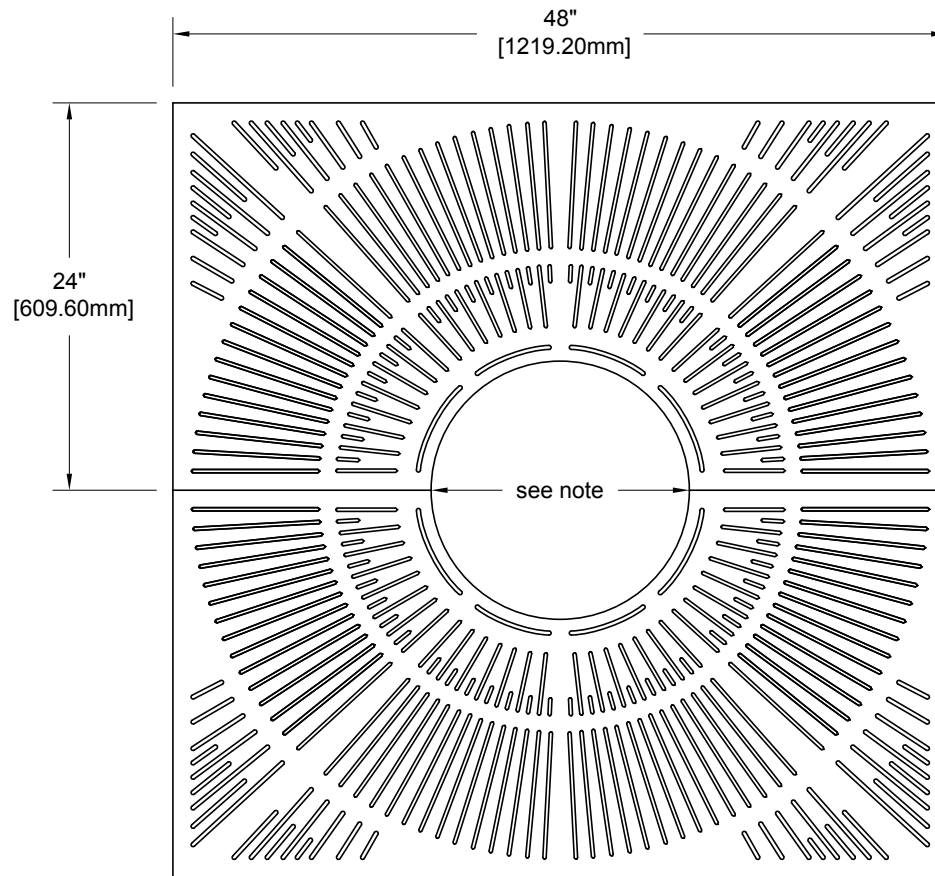

4814-1 STARBURST TREE GRATE

48" x 48" tree grate in two sections.

1/4 Maximum slot opening for pedestrian safety and A.D.A Compliance.

Cast from 100% recycled Iron, Aluminum, or Bronze for pedestrian loads only.

Tree opening:
16", 18", 28"
Grates can be ordered with or later expanded to these openings. please specify when ordering.

Finish: unfinished or Black dip or Enamel paint or Polyurethane Paint or Powder coat
Specify finish and color

Use frame model:
4800F

Weight:
Iron= 325 lb/ 148 Kg
Aluminum=120 lb/55 Kg

This drawing embodies a confidential proprietary design of IRONSMITH, INC. Palm Desert, Ca. All design, manufacturing, reproduction, use, sale, and other rights regarding the same are expressly reserved. This drawing is submitted under confidential relationship for a specific purpose and the recipient agrees by accepting this drawing not to supply or disclose any information regarding it to any unauthorized person or to incorporate any special feature peculiar to this design in other projects. The information in this drawing may be covered completely or in part by patents pending.

IRONSMITH

41-701 Corporate Way #3
Palm Desert, CA 92260
800.338.4766

Streetscape Elements

LIGHTING

DIVISION MATRIX SHEET

- Decorative lighting
- Pedestrian lights

Legend:

- Active Street Type 1
- Active Street Type 2
- Active Street Type 3

HOD Streetscape Standard

Other Standard

DECORATIVE LIGHTING



PEDESTRIAN LIGHTING

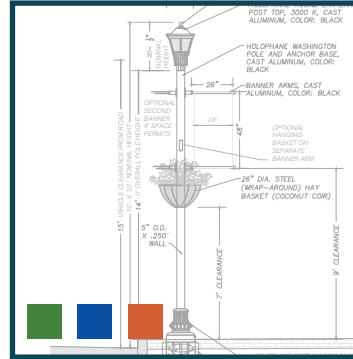

Streetscape Elements

DECORATIVE LIGHTING

Description

Enhancing the HOD with appropriate seasonal lighting, throughout the calendar year, will add interest and identity.

Style

- LED styled temporary lighting

Size

Illumination levels will conform to Ordinance requirements

Materials and Color

- Limit to warm white in color temperature
- Do not exceed 3500 Kelvin

Location and Setbacks

- Attached to LED Pedestrian Lights

Requirements

- Meets ULI standards for outdoor use
- Limited to six-week long display time period per installation
- No flashing or intermittent lighting permitted unless allowed by City ordinance
- Design plan and material submission required for approval prior to installation



Photo Credit: City of Fairfax

Old Town Square with decorative, seasonal lighting

Streetscape Elements

PEDESTRIAN LIGHTING

Description

Standard pedestrian fixture and pole combination for use throughout the HOD

Style

- Holophane supplied fixture/pole/base (as shown on detail as supplied by Holophane)
- Dominion supplied fixture/pole/base (as shown on detail as supplied by Dominion/LED catalog)

Size

- 12' mounting height pole (mounting height must be consistent on both block faces between intersections)
- 14' mounting height pole (mounting height must be consistent on both block faces between intersections)

Materials and Color

- Aluminum pole
- Powder-coat black

Location and Setbacks

- Pedestrian light poles in 45 MPH or less posted speed limit roadway may be placed 18 inches off of curb face where curb meets VDOT Standard details CG-2 or CG-6 detail, per VDOT Standards for clear zone
- Pedestrian light poles in greater than 45 MPH posted speed limit roadway to follow VDOT Standards for clear zone
- Spacing of pedestrian fixtures and poles to be determined by photometric study

Requirements

- Illumination levels to meet IESNA American National Standard Practice for Roadway Lighting (RP-8-14) for public sidewalk lighting
- Breakaway pole accessory
- Clamshell base



Pedestrian light with hayrack basket and single banner on left and double banners on right

Optional

- Banner arm(s) - dependent upon location
- Hayrack basket OR hanging basket

Sources

The fixture, pole, and clamshell combination is available for purchase directly from the vendor Acuity Brands/Holophane or for lease from Dominion.

Dominion LED Catalog (lease)

Holophane Sales Channel (purchase)

Acuity Brands Lighting, Inc.

m 443-462-7883

<https://holophane.acuitybrands.com/>

Streetscape Elements



CUSTOMER NOTES:
 1. CUSTOMER MUST VERIFY ACCESSORY HEIGHTS & ORIENTATIONS BELOW DURING APPROVAL AND MUST BE PROVIDED PRIOR TO PRODUCTION. MAY BE ROTATED IN DRAWING VIEW FOR CLARITY.
 2. APPROVED AND COMPLETED SUBMITTAL TO ACCOMPANY PO.

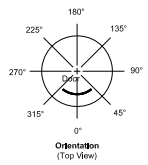

Accessory Mounting Detail

	Orientation	Height
BANNER ARMS	90°	9'-0" & 14'-0"
BANNER ARMS	270°	9'-0" & 14'-0"
PLANTER ARM	0°	10'-0"
RECEPTACLE	0°	13'-6"

NOTE: Confirm banner arm mounting height with City of Fairfax prior to production; current banner length is 48".

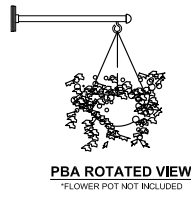

Catalog #'s:
 Pole: 14006060854-3T3-GFI-PROVS-WA24CSB-BK RFD296489
 Anchor Bolts; LEX1*ABSET RFD296489
 Banner Arms; (4)BA24B0H3BK
 Planter Arm; PBA18B0H4BK-EB RFD296489
 Fixture: PTUE2* (Please see sales rep for standard luminaire cut sheet.)

Customer Signature & Date:

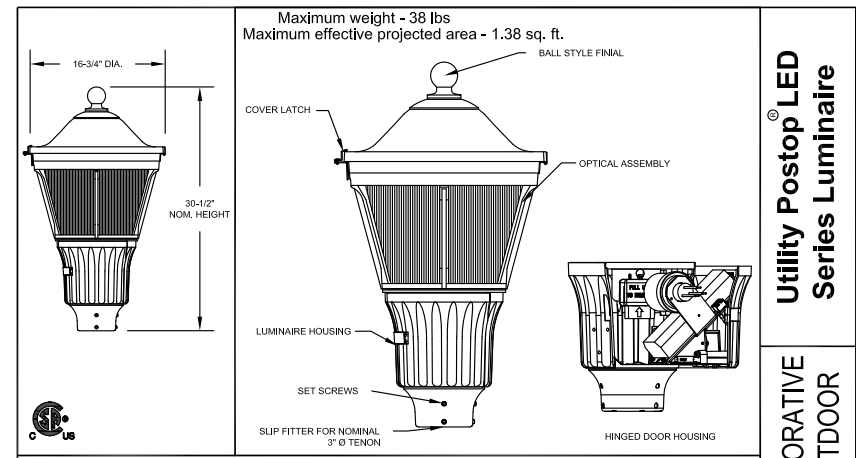

PTUE2	P40	30K	AS	GL3	BK	B
HOUSING STYLE PTUE2= UTILITY POSTOP LED POST TOP	COLOR TEMPERATURE 27K = 2700 K CCT 30K = 3000 K CCT 40K = 4000 K CCT 50K = 5000 K CCT	VOLTAGE AS = AUTO-SENSING (120-277) 50/60 HZ AH = AUTO-SENSING (347-480) 50/60 HZ	COLOR BK = BLACK BZ = BRONZE GH = GRAPHITE GN = GREEN GR = GREY PP = PRIME PAINT WH = WHITE CMC = CUSTOM MATCH COLOR TDC = TIGER DRYLAC COLOR (RALxxx) XX = STD FINISH, TBD	FINIAL B = BALL S = SPIKE N = NONE	LED PERFORMANCE PACKAGE (SEE PERFORMANCE DATA TABLE FOR DETAILS, PAGE 2) P10 = LED PERFORMANCE PACKAGE P20 = LED PERFORMANCE PACKAGE P30 = LED PERFORMANCE PACKAGE P40 = LED PERFORMANCE PACKAGE P50 = LED PERFORMANCE PACKAGE	
OPTICS ACRYLIC REFRACTOR AV3 = TYPE 3 AV5 = TYPE 5 GLASS REFRACTOR GL3 = TYPE 3 POLYCARBONATE REFRACTOR PV3 = TYPE 3 PV5 = TYPE 5						

OPTIONS	ACCESSORIES
CONTROL OPTIONS AC = FIELD ADJUSTABLE OUTPUT DE = ROAM HARDWARE AND DECO NODE FDPxx = FACTORY PROGRAMMED DRIVER P3 = NEMA TWISTLOCK RECEPTACLE INTERNALLY MOUNTED - 3 PIN P3E = NEMA TWISTLOCK RECEPTACLE EXTERNALLY MOUNTED - 3 PIN P7 = NEMA TWISTLOCK RECEPTACLE INTERNALLY MOUNTED - 7 PIN P7E = NEMA TWISTLOCK RECEPTACLE EXTERNALLY MOUNTED - 7 PIN P34 = DTL TWISTLOCK PHOTOCONTROL 347V P48 = DTL TWISTLOCK PHOTOCONTROL 480V PCL = DTL LONG LIFE TWISTLOCK PHOTOCONTROL FOR SOLID STATE "AS" & "AH" PCS = DTL TWISTLOCK PHOTOCONTROL FOR SOLID STATE "AS" PND = 0-10V PART NIGHT DIMMING PSC = SHORTING CAP RME = ROAM NODE (120-277V) EXTERNALLY MOUNTED WITH 7 PIN RME3 = ROAM NODE (347V) EXTERNALLY MOUNTED WITH 7 PIN RME4 = ROAM NODE (480V) EXTERNALLY MOUNTED WITH 7 PIN NEMA LABEL OPTION NLX1 = 1"x1" ANSI WATTAGE LABEL 20KV = 20KV/10KA SURGE PROTECTION NLX2 = 2"x2" ANSI WATTAGE LABEL PREWIRED LEAD OPTIONS L1H = 1.5 FEET OF PREWIRED LEADS L03 = 3 FEET OF PREWIRED LEADS L10 = 10 FEET OF PREWIRED LEADS L20 = 20 FEET OF PREWIRED LEADS L26 = 26 FEET OF PREWIRED LEADS L30 = 30 FEET OF PREWIRED LEADS	HOUSE SIDE SHIELD FIELD INSTALLED OPTIONS PHSS90 = HOUSE SIDE SHIELD SOLID 90 DEGREE PHSS120 = HOUSE SIDE SHIELD SOLID 120 DEGREE PHSS180 = HOUSE SIDE SHIELD SOLID 180 DEGREE SURGE REPLACEMENT FIELD INSTALLED OPTIONS SPDPLUG-IN-AS = REPLACEMENT FOR 120-277V SPDPLUG-IN-AH = REPLACEMENT FOR 347-480V SPDPLUG-IN-AS-20KV = REPLACEMENT FOR 120-277V 20KV/10KA SPDPLUG-IN-AH-20KV = REPLACEMENT FOR 347-480V 20KV/10KA

FOR COMPATIBLE OPTIONS, REFER TO THE OPTION MATRIX ON PAGE 3 OF 4



TITLE: S ASSEMBLY	QTY: 27
MODEL NO.: 14005050854H (A14336)	DWN BY: HJT/MAB
MATERIAL: ALUMINUM ALLOY	CHKD BY:
FINISH: POWDER PAINT- HOLOPHANE BLACK LAVA	APPR BY:
PROJECT: CITY OF FAIRFAX - LARDNER KLEIN	DATE: 12/11/18
SOLD TO: RFD296489, DR18154	DWG NO.: TSG011140
SHIP TO:	PAGE: 3 / 3
P.O. NO.: 2400-18-10030-4	
REP.: MEGAN FALCONE	
REV	DATE
	REVISION DESCRIPTION
	BY

Utility Postop® LED Series Luminaire

DECORATIVE OUTDOOR



THIS DRAWING, WHEN APPROVED, SHALL BECOME THE COMPLETE SET OF CONTRACT DOCUMENTS. THE CONTRACTOR SHALL BE RESPONSIBLE FOR OBTAINING ALL NECESSARY PERMITS AND APPROVALS. THE CONTRACTOR SHALL BE RESPONSIBLE FOR VERIFYING ALL DIMENSIONS AND CONDITIONS OF THE SITE PRIOR TO CONSTRUCTION. THE CONTRACTOR SHALL BE RESPONSIBLE FOR OBTAINING ALL NECESSARY PERMITS AND APPROVALS. THE CONTRACTOR SHALL BE RESPONSIBLE FOR OBTAINING ALL NECESSARY PERMITS AND APPROVALS.

ORDER #:
 TYPE:
 DRAWN: MRP
 DATE: 02/01/2018
 DWG #: LUM-PTUE2

Streetscape Elements

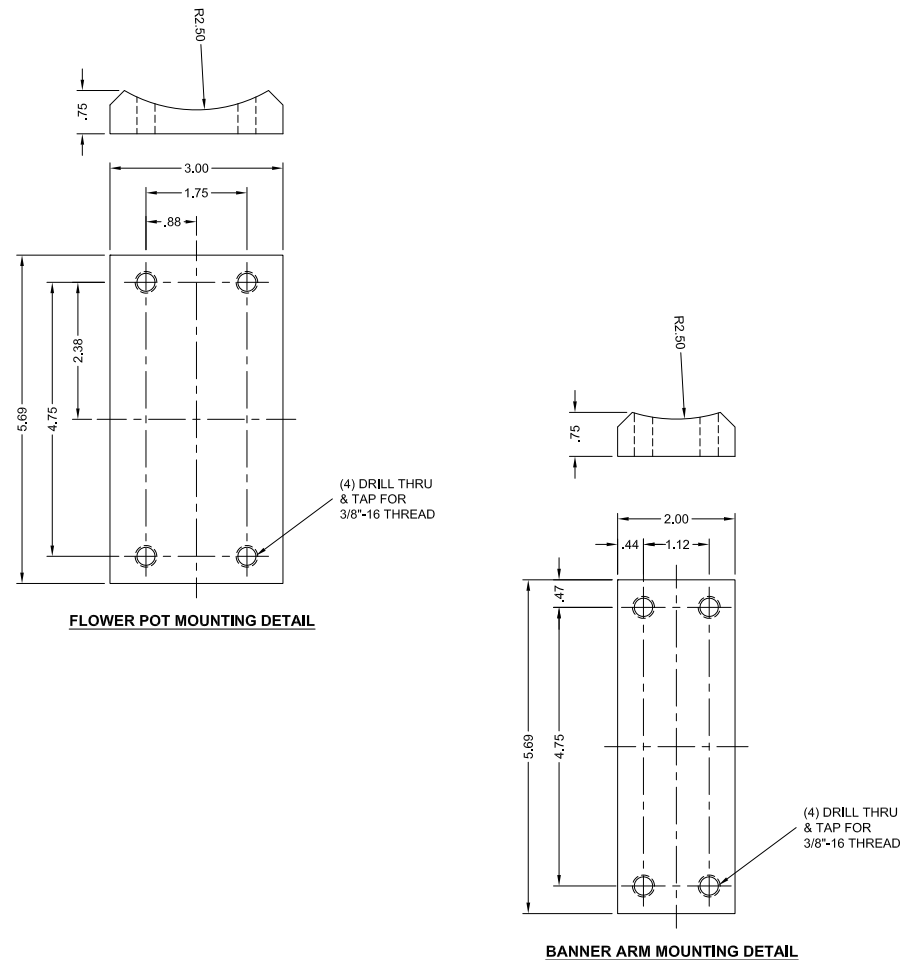
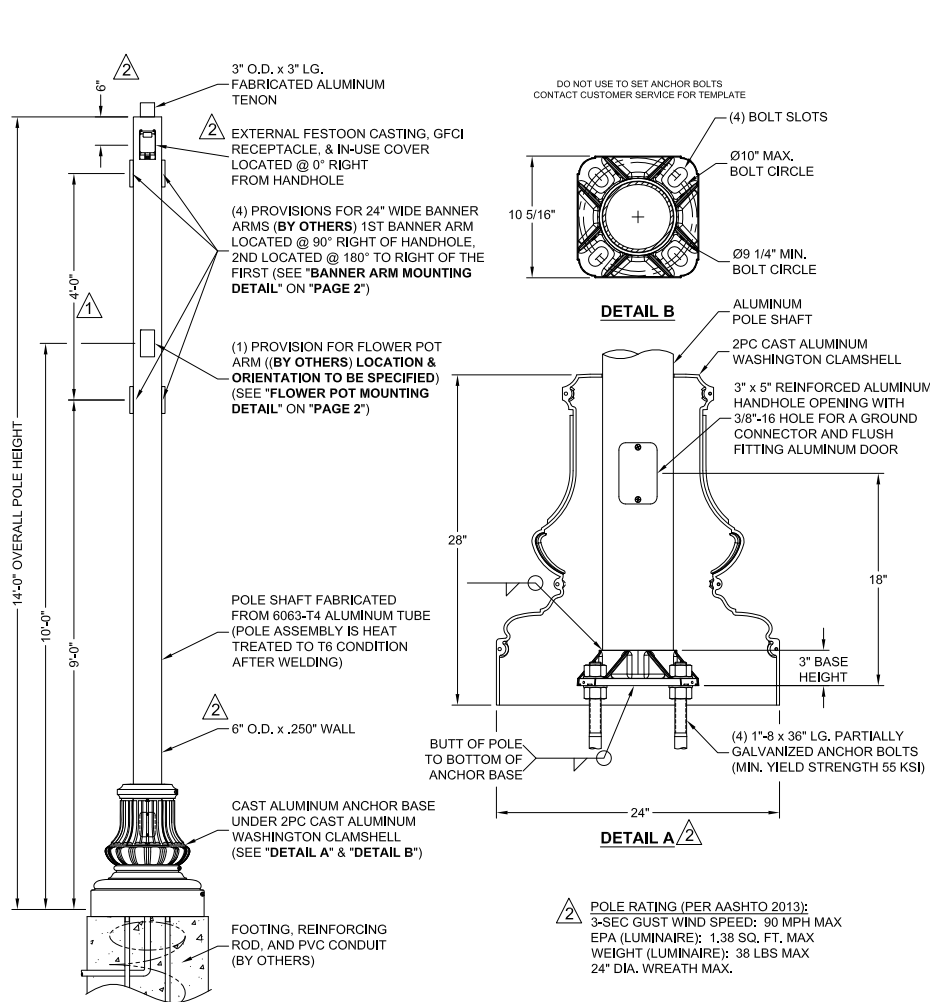

<p>HOLOPHANE LEADER IN LIGHTING SOLUTIONS 3825 Columbus RD., Granville, Ohio 43023</p>		<p>TITLE: S ANCHOR BASE POLE</p> <p>MODEL NO.: 140050508S4H (A14336)</p> <p>MATERIAL: ALUMINUM ALLOY</p> <p>FINISH: POWDER PAINT- HOLOPHANE BLACK LAVA</p> <p>PROJECT: CITY OF FAIRFAX - LARDNER KLEIN</p> <p>SOLD TO: RFD296489, DR18154</p> <p>SHIP TO:</p> <p>P.O. NO.: 2400-18-10030-4</p> <p>REP.: MEGAN FALCONE</p>	<p>QTY: 27</p> <p>DWN BY: HJT/MAB</p> <p>CHKD BY:</p> <p>APPR BY:</p> <p>DATE: 12/11/18</p> <p>DWG NO.: TSG011140</p> <p>HJT</p> <p>PTT</p> <p>PAGE:</p>	<p>Catalog #s: (*See Complete Cat. Nos. on Sheet 3)</p> <p>Customer Signature & Date:</p>
<p>2/12/19</p>	<p>CHG POLE O.D.;REV DRLS;ADD FSTN;REV EPA</p>	<p>HJT</p>	<p>1/3</p>	
<p>1/31/19</p>	<p>CHANGED BANNER DIMENSION</p>	<p>PTT</p>		
REV	DATE	REVISION DESCRIPTION	BY	

****CONFIDENTIAL****
The information contained in this drawing is privileged and confidential, and may be protected from disclosure. Please be aware that any use or dissemination of this drawing may be subject to legal restriction or sanction.

<p>HOLOPHANE LEADER IN LIGHTING SOLUTIONS 3825 Columbus RD., Granville, Ohio 43023</p>		<p>TITLE: S MOUNTING PLATE DETAILS</p> <p>MODEL NO.: (A14336)</p> <p>MATERIAL: ALUMINUM ALLOY</p> <p>FINISH: POWDER PAINT- HOLOPHANE BLACK LAVA</p> <p>PROJECT: CITY OF FAIRFAX - LARDNER KLEIN</p> <p>SOLD TO: RFD290446, DR17564</p> <p>SHIP TO:</p> <p>P.O. NO.: 2400-18-10030-1</p> <p>REP.: MEGAN FALCONE</p>	<p>QTY: 27</p> <p>DWN BY: HJT/MAB</p> <p>CHKD BY:</p> <p>APPR BY:</p> <p>DATE: 12/11/18</p> <p>DWG NO.: TSG011140</p> <p>HJT</p> <p>PTT</p> <p>PAGE:</p>	<p>**CONFIDENTIAL** The information contained in this drawing is privileged and confidential, and may be protected from disclosure. Please be aware that any use or dissemination of this drawing may be subject to legal restriction or sanction.</p>
REV	DATE	REVISION DESCRIPTION	BY	

Streetscape Elements

Banner Arms

Standard Banner Arm

SiteLink Banner Arm

Options

Scroll and Eye Bolt Banner Arm
BA24BOH4BKST

Eye Bolt Banner Arm
BA24BOH5BKF

Finial Options

Cast Aluminum

A = Acron

B = Ball

H = Half Sphere

R = Raleigh

Specifications

FEATURES:
Tool-less banner installation and/or replacement. As a safety feature the break-away couplings are fitted with 3/32Ø 7x7 strand stainless steel aircraft cable.

DESCRIPTION
The banner arms shall consist of an aluminum 6061 schedule 80 pipe or aluminum extrusion, an aluminum channel mounting plate, and a cast aluminum coupling. Stainless steel eyebolts, scrolls, and breakaway banner arms are optional. Breakaway banner arms may be recommended for some types of banners.

CONSTRUCTION
The banner arm shall be installed into a cast aluminum coupling with a stainless steel latch-pin.

MATERIALS
The finial shall be cast aluminum, produced from certified ASTM 356 ingot per ASTM B-179-95a or ASTM B26-95 and welded to the end of the banner arm. The banner arm mounting plate shall be aluminum, ASTM 356 alloy, heat treated to a T6 temper. All hardware shall be stainless steel.

INSTALLATION
Bolt the cast aluminum coupling to the mounting channel (welded to the side of the pole) using 3/8-16 stainless screws. Slip the banner arm into the coupling and secure in place with 1/4" stainless steel latch pin. Note: Arms are not designed for pedestrian interference. Banners to be provided by others.

DIMENSIONS
The banner arms shall be available in 1.05", 1.32", 1.66" or 1.9" O.D. with length to be specified in whole Inch increments.

*CAUTION
EYE BOLT LOAD LIMIT
= 100 LB MAXIMUM

Banner Arms

ORDER #:	TYPE:	DRAWING #:
REVISION:	REVISION DATE: 10/30/14	US-2410
DRAWN: KRW	ORIGIN DATE: 5/7/13	PAGE: 1 of 1

THIS DRAWING, WHEN APPROVED, SHALL BECOME THE COMPLETE SPECIFICATION FOR THE MATERIAL TO BE FURNISHED BY THE ORDER NOTED ABOVE. A UNIT OF SIMILAR DESIGN MAY BE SUPPLIED, BUT ONLY AFTER APPROVAL BY THE CUSTOMER IN WRITING. ON POLE ORDERS AN ANCHOR BOLT TEMPLATE PRINT WILL BE SUPPLIED WITH EACH ANCHOR BOLT ORDER TO MATCH THE POLE PROVIDED. THIS PRINT IS THE PROPERTY OF HOLOPHANE AND IS LOANED SUBJECT TO RETURN UPON DEMAND AND UPON EXPRESS CONDITION THAT IT WILL NOT BE USED DIRECTLY OR INDIRECTLY IN ANY WAY DETRIMENTAL TO OUR INTERESTS, AND ONLY IN CONNECTION WITH MATERIAL FURNISHED BY HOLOPHANE.

Mark Appropriate Box for Finial Option

Finial Options

No Finial (N) Ball (B) Spike (S)

Utility Postop LED Series Luminaire

Specifications

Mechanical Specifications
The luminaire housing shall:

- Be heavy grade A360 cast aluminum (aluminum with <1% copper)
- Be tool-less access with a spring-loaded latch
- Incorporate a hidden hinge door allowing the door to swing open and remain open
- Offer units with an E.E.I.-N.E.M.A. twist lock photocontrol receptacle, the housing must contain a tempered glass lens "window" to allow light to reach the cell
- Mount to a splittler that will accept a 3" high by 2-7/8" to 3-1/8" O.D. pole tenon

The decorative cover shall:

- Be heavy grade A360 cast aluminum (aluminum with <1% copper)
- Be attached to the top ring of the luminaire housing using a stainless-steel piano hinge and latched by an over-center, positive action, stainless steel latch which secures entry to the LED optical chamber
- The finish shall:
 - Utilize a polyester powder paint to ensure maximum durability
 - Meet 10,000-hour salt spray test
 - Offer Tiger Drylac finishes that are applied by a Tiger Drylac certified facility

Electrical Specifications
The driver shall be meeting the following requirements:

- Certified by UL or CSA
- A programmable electronic driver with 0-10V control leads
- Available in: 120-277V 50/60 Hz and 347-480V 60 Hz
- Manufactured by Osram, Philips, ULT or Thomas Research
- LEDs shall have a minimum of 70 CRI and available in 2700K, 3000K, 4000K and 5000K CCT and manufactured by:
 - Samsung, Nichia or Cree
 - The electrical system shall be designed to meet ANSI/IEEE C82.41.2 and shall:
 - Offer a 10kV/5kA surge protection as standard
 - Offer a 20kV/10kA surge protection option

Optical Specifications

The light engine housing shall be IP66. Two gaskets shall be part of the optical system, one on the top and bottom ridge. The optical system must consist of the following materials and include I.E.S. distributions:

- Prismatic borosilicate glass: Type III (borosilicate glass maximizes resistance to impact, thermal resistant, resisting brownning and coefficient of utilization)
- Prismatic Acrylic: Type III & Type V
- Prismatic Polycarbonate: Type III & Type V

Control Options
The control options shall include, but not limited to, the following:

- Field adjust output to adjust lumen output at the luminaire - AO
- Wireless remote control for monitoring performance and/or maintenance of the system - ROAM
- Customize lumen output prior to manufacturing (FPDxx) and still enables control leads so other options can also be used
- Long life photocontrol, 20 years - PCL with DTL
- 3 and 7 pin receptacles internally (P3, P7) or externally (P3E, P7E) mounted
- Part-night dimming enables luminaire to monitor and adjust 50% lumens based on season and geographical location, 8 day rolling average - PND

Certification and Standards

- Luminaire shall be UL or CSA listed per CSA luminaire standard CSA
- Suitable for operation in an ambient temperature up to 40°C / 104°F per UL or CSA certification
- DesignLights Consortium® (DLC) qualified product. Not all versions of this product may be DLC qualified. Please check the DLC Qualified Products list at www.designlights.org/QPL to confirm which versions are qualified.
- LM-79 compliant
- The projected LED Lumen Maintenance shall be based only on IES LM-80-08, current, and not TM-21.

Warranty - 5 Years Limited
Complete warranty terms located at:
www.acuitybrands.com/CustomerResources/Terms_and_conditions.aspx

THIS DRAWING, WHEN APPROVED, SHALL BECOME THE COMPLETE SPECIFICATION FOR THE MATERIAL TO BE FURNISHED BY THE ORDER NOTED ABOVE. A UNIT OF SIMILAR DESIGN MAY BE SUPPLIED, BUT ONLY AFTER APPROVAL BY THE CUSTOMER IN WRITING. ON POLE ORDERS AN ANCHOR BOLT TEMPLATE PRINT WILL BE SUPPLIED WITH EACH ANCHOR BOLT ORDER TO MATCH THE POLE PROVIDED. THIS PRINT IS THE PROPERTY OF HOLOPHANE AND IS LOANED SUBJECT TO RETURN UPON DEMAND AND UPON EXPRESS CONDITION THAT IT WILL NOT BE USED DIRECTLY OR INDIRECTLY IN ANY WAY DETRIMENTAL TO OUR INTERESTS, AND ONLY IN CONNECTION WITH MATERIAL FURNISHED BY HOLOPHANE.

© 2015 Acuity Brands Lighting, Inc. All rights reserved.

ORDER #:

TYPE: MRP

DATE: 02/01/2018

DWG #: LUM_PTUE2

4 of 4

Streetscape Elements

Performance Data

LED Package	Distribution	System					27K (2700K, 70 CRI)					30K (3000K, 70 CRI)					40K (4000K, 70 CRI)					50K (5000K, 70 CRI)							
		Watts	Lumens	LPW	B	U	G	Lumens	LPW	B	U	G	Lumens	LPW	B	U	G	Lumens	LPW	B	U	G	Lumens	LPW	B	U	G		
P10	GL3	35	3,168	91	1	3	3	3,276	96	1	3	3	3,543	101	1	3	3	3,689	105	2	3	3	3	3	3	3	3	3	
	AY3	35	3,277	92	1	3	3	3,439	98	1	3	3	3,609	103	1	3	3	3,757	107	2	3	3	3	3	3	3	3	3	
	AYS	35	3,007	86	2	3	2	3,204	92	2	3	2	3,363	96	2	3	2	3,501	100	2	3	2	3	2	3	2	3	2	
	PY3	35	2,823	81	1	3	3	3,009	86	1	3	3	3,157	90	1	3	3	3,287	94	1	3	3	3	3	3	3	3	3	3
	PY5	35	2,628	75	2	3	2	2,801	80	2	3	2	2,939	84	2	3	2	3,060	87	2	3	2	3	2	3	2	3	2	
P20	GL3	55	4,917	89	2	3	3	5,240	95	2	3	3	5,499	100	2	3	3	5,726	104	2	4	4	4	4	4	4	4	4	
	AY3	55	5,008	91	2	4	4	5,338	97	2	4	4	5,601	102	2	4	4	5,832	106	2	4	4	4	4	4	4	4	4	
	AYS	55	4,666	85	3	4	3	4,973	90	3	4	3	5,219	95	3	4	3	5,434	99	3	4	3	4	3	4	3	4	3	
	PY3	55	4,381	80	2	3	4	4,670	85	2	3	4	4,900	89	2	3	4	5,102	93	2	3	4	4	4	4	4	4	4	
	PY5	55	4,079	74	2	3	3	4,348	79	2	3	3	4,562	83	2	4	3	4,750	86	3	4	3	4	3	4	3	4	3	
P30	GL3	76	6,745	89	2	4	4	7,188	95	3	4	4	7,543	99	3	4	4	7,854	103	3	4	4	4	4	4	4	4	4	
	AY3	76	6,870	90	2	4	4	7,322	96	2	4	4	7,683	101	3	4	5	8,000	105	3	4	4	5	5	5	5	5	5	
	AYS	76	6,401	84	3	4	3	6,822	90	3	4	3	7,159	94	3	4	3	7,454	98	3	4	3	4	3	4	3	4	3	
	PY3	76	6,010	79	2	4	5	6,405	84	2	4	5	6,722	88	2	4	5	6,999	92	2	4	5	5	5	5	5	5	5	
	PY5	76	5,596	74	3	4	3	5,964	78	3	4	3	6,258	82	3	4	3	6,516	86	3	4	3	4	3	4	3	4	3	
P40	GL3	102	8,946	87	3	4	5	9,428	92	3	4	5	9,894	97	3	4	5	10,301	101	3	4	5	5	5	5	5	5	5	
	AY3	102	9,010	88	3	4	5	9,603	94	3	4	5	10,077	99	3	4	5	10,492	103	3	4	5	5	5	5	5	5	5	
	AYS	102	8,396	82	3	4	4	8,948	88	3	4	4	9,390	92	3	5	4	9,776	96	3	5	4	4	4	4	4	4	4	
	PY3	102	7,853	77	3	4	5	8,401	82	3	4	5	8,816	86	3	4	5	9,179	90	3	4	5	5	5	5	5	5		
	PY5	102	7,339	72	3	4	4	7,822	77	3	4	4	8,208	80	3	4	4	8,546	84	3	4	4	4	4	4	4	4		
P50	GL3	139	11,517	83	3	5	5	12,275	88	3	5	5	12,881	93	3	5	5	13,411	96	3	5	5	5	5	5	5	5		
	AY3	139	11,731	84	3	5	5	12,503	90	3	5	5	13,120	94	3	5	5	13,660	98	3	5	5	5	5	5	5	5		
	AYS	139	10,930	79	4	5	4	11,649	84	4	5	4	12,225	88	4	5	5	12,728	92	4	5	5	5	5	5	5	5		
	PY3	139	10,262	74	3	5	5	10,938	79	3	5	5	11,478	83	3	5	5	11,950	86	3	5	5	5	5	5	5	5		
	PY5	139	9,555	69	3	5	4	10,183	73	3	5	5	10,686	77	3	5	5	11,126	80	3	5	5	5	5	5	5	5		

Utility Postop LED Series Luminaire

DECORATIVE OUTDOOR

HOLOPHANE An Acuity Brands Company

THIS DRAWING AND ALL INFORMATION HEREON IS THE PROPERTY OF HOLOPHANE, INC. AND IS NOT TO BE REPRODUCED OR TRANSMITTED IN ANY FORM OR BY ANY MEANS, ELECTRONIC OR MECHANICAL, INCLUDING PHOTOCOPYING, RECORDING, OR BY ANY INFORMATION STORAGE AND RETRIEVAL SYSTEM, WITHOUT THE WRITTEN PERMISSION OF HOLOPHANE, INC. ALL RIGHTS ARE RESERVED. THE TRADE NAMES OF HOLOPHANE AND THE HOLOPHANE LOGO ARE TRADEMARKS OF HOLOPHANE, INC. © 2009 Acuity Brands Lighting, Inc. All Rights Reserved.

ORDER #: 2 OF 4
TYPE: MRP
DRAWING: 02/01/2018
DATE: MRP
DWG #: LUM_P10E2

OPTIONS MATRIX

Parameters	SELECTED OPTION (start here)															
	AO	DE	FPDxx	P3	P3E	P7	P7E	P34	P48	PCLL	PCS	PND	PSC	RME	RME3	RME4
LED Performance Package	P10	Y	Y	Y	Y	Y	Y	Y	Y	Y	Y	Y	Y	Y	Y	Y
	P20	Y	Y	Y	Y	Y	Y	Y	Y	Y	Y	Y	Y	Y	Y	Y
	P30	Y	Y	Y	Y	Y	Y	Y	Y	Y	Y	Y	Y	Y	Y	Y
	P40	Y	Y	Y	Y	Y	Y	Y	Y	Y	Y	Y	Y	Y	Y	Y
	P50	N	N	N	N	N	N	N	N	N	N	N	N	N	N	N
Voltage	AS	Y	Y	Y	Y	Y	Y	N	N	N	N	N	N	N	N	N
	AH	Y	N	Y	Y	Y	Y	Y	Y	Y	Y	N	Y	N	Y	Y
Finial	B	Y	Y	Y	Y	N	Y	N	Y	Y	Y	Y	Y	N	N	N
	S	Y	Y	Y	N	N	N	N	Y	Y	Y	Y	Y	N	N	N
	N	Y	Y	Y	M	Y	M	Y	Y	Y	Y	Y	M	M	M	M
Compatible Options	AO	N	Y	Y	Y	F	F	Y	Y	Y	Y	N	Y	N	N	N
	DE	N	Y	Y	Y	Y	Y	N	N	N	N	N	N	N	N	N
	FPDxx	Y	Y	Y	N	N	N	Y	Y	Y	Y	Y	Y	Y	Y	Y
	P3	Y	Y	Y	N	N	N	M	M	M	M	I	N	N	N	N
	P3E	Y	N	Y	N	N	N	M	M	M	M	N	M	N	N	N
	P7	F	Y	Y	N	N	N	M	M	M	M	N	M	N	N	N
	P7E	F	N	Y	N	N	N	M	M	M	M	N	M	I	I	I
	P34	Y	N	Y	M	M	M	M	M	N	N	N	N	N	N	N
	P48	Y	N	Y	M	M	M	M	N	N	N	N	N	N	N	N
	PCLL	Y	N	Y	M	M	M	M	N	N	N	N	M	N	N	N
PCS	Y	N	Y	M	M	M	M	N	N	N	M	N	N	N	N	
PND	N	N	Y	M	M	M	M	N	N	N	M	N	N	N	N	
PSC	Y	N	Y	M	M	M	M	N	N	N	N	N	N	N	N	
RME	N	N	Y	N	N	N	N	N	N	N	N	N	N	N	N	
RME3	N	N	Y	N	N	N	N	N	N	N	N	N	N	N	N	
RME4	N	N	Y	N	N	N	N	N	N	N	N	N	N	N	N	

OPTIONS MATRIX Legend
I = Included with selected option
F = Future ready (wired with "AO", but could accept control device with tooHess field wiring)
M = Must have: one of these must be installed for the luminaire to operate
N = Combination not available
Y = Valid Option Combination

ROAM Option Details
DE: UL listed device without GPS capability, external antenna is black and includes ROAM capable node only, ROAM service package sold separately via Acuity Controls and contact Acuity Controls for RME device with GPS capability or non-standard housing color
RME: UL listed device without GPS capability, blue housing color, includes ROAM capable node only, ROAM service package sold separately via Acuity Controls and contact Acuity Controls for RME device with GPS capability or non-standard housing color
RME3: UL listed device without GPS capability, green housing color, includes ROAM capable node only, ROAM service package sold separately via Acuity Controls and contact Acuity Controls for RME device with GPS capability or non-standard housing color
RME4: UL listed device without GPS capability, yellow housing color, includes ROAM capable node only, ROAM service package sold separately via Acuity Controls and contact Acuity Controls for RME device with GPS capability or non-standard housing color

Lumen Ambient Temperature (LAT) Multipliers
Use these factors to determine relative lumen output for average ambient temperatures from 0-40°C (32-104°F).

Average Lumen Ambient Temperature (LAT) Multipliers		LED Packages	
°C	°F	Lumen Multiplier	LED Packages
0	32	1.04	P10, P20, P30, P40, P50
5	41	1.03	
10	50	1.02	
15	59	1.01	
20	68	1.01	
25	77	1.00	
30	86	0.99	
35	95	0.98	
40	104	0.98	

Projected LED Lumen Maintenance
Data references the extrapolated performance projections for the platforms noted in a 25°C ambient, based on 6,000 hours of LED testing (tested per IESNA LM-80-08 and projected per IESNA TM-21-11).

To calculate LLF, use the lumen maintenance factor that corresponds to the desired number of operating hours below. For other lumen maintenance values, contact factory.

Lumen Maintenance - LLF (same for all LED packages)							
Hours	0	25,000	36,000	50,000	60,000	75,000	100,000
Factor	1	0.93	0.91	0.87	0.85	0.82	0.77

The italicized data is extrapolated beyond the TM-21 standard.

E = (LM) x (CU) x (LAT) x (LLD)
LM and CU are obtained from published photometry.

Utility Postop LED Series Luminaire

DECORATIVE OUTDOOR

HOLOPHANE An Acuity Brands Company

THIS DRAWING AND ALL INFORMATION HEREON IS THE PROPERTY OF HOLOPHANE, INC. AND IS NOT TO BE REPRODUCED OR TRANSMITTED IN ANY FORM OR BY ANY MEANS, ELECTRONIC OR MECHANICAL, INCLUDING PHOTOCOPYING, RECORDING, OR BY ANY INFORMATION STORAGE AND RETRIEVAL SYSTEM, WITHOUT THE WRITTEN PERMISSION OF HOLOPHANE, INC. ALL RIGHTS ARE RESERVED. THE TRADE NAMES OF HOLOPHANE AND THE HOLOPHANE LOGO ARE TRADEMARKS OF HOLOPHANE, INC. © 2009 Acuity Brands Lighting, Inc. All Rights Reserved.





ORDER #: 3 OF 4
TYPE: MRP
DRAWING: 02/01/2018
DATE: MRP
DWG #: LUM_P10E2

Streetscape Elements

PAVEMENT DIVISION MATRIX SHEET

- Bulb out
- Crossing island
- Crosswalk - HOD impressed preformed thermoplastic
- Crosswalk - HOD - Main Street vehicular brick paver
- Crosswalk - HOD - Main Street impressed preformed thermoplastic
- Crosswalk - standard/zebra
- Curb and gutter
- Curb ramp - brick
- Curb ramp - concrete
- Driveway apron - brick
- Driveway apron - with curb and gutter
- Driveway apron - concrete

Legend:

-  Active Street Type 1
-  Active Street Type 2
-  Active Street Type 3
-  HOD Streetscape Standard
-  Other Standard

BULB OUT

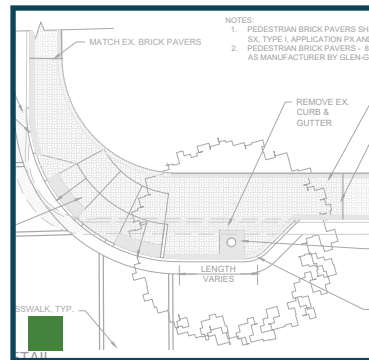

CROSSING ISLAND

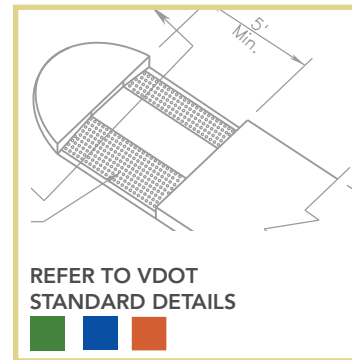

CROSSWALK - HOD IMPRESSED PREFORMED THERMOPLASTIC ON ASPHALT SURFACE

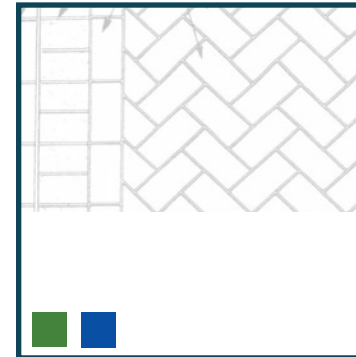

CROSSWALK - HOD MAIN STREET - VEHICULAR BRICK PAVER

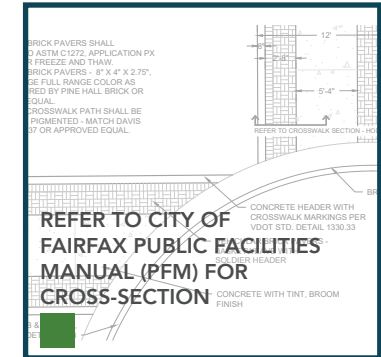

CROSSWALK - HOD - MAIN STREET IMPRESSED PREFORMED THERMOPLASTIC/ASPHALT

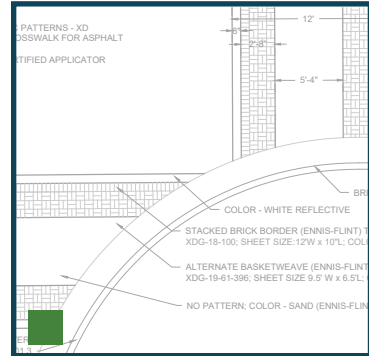

CROSSWALK - STANDARD/ZEBRA

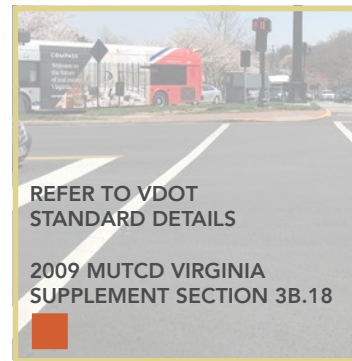

CURB AND GUTTER



CURB RAMP - BRICK

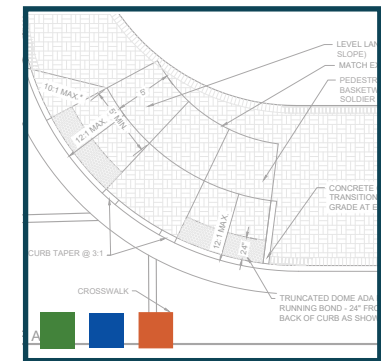

CURB RAMP - CONCRETE

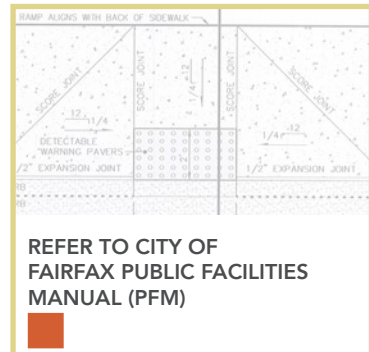

DRIVEWAY APRON - BRICK

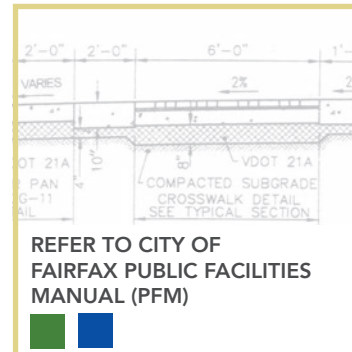

DRIVEWAY APRON - WITH CURB AND GUTTER

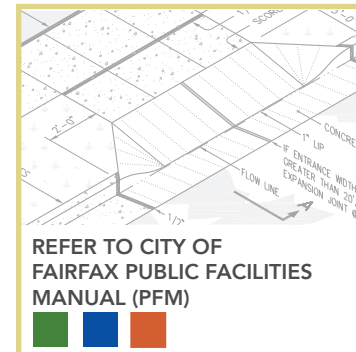

DRIVEWAY APRON - CONCRETE







Streetscape Elements

PAVEMENT, CONTINUED DIVISION MATRIX SHEET

- Intersection - HOD Main Street vehicular brick paver
- Intersection - HOD Main Street impressed preformed thermoplastic
- Loading zone/parking space markings
- Loading zone/parking space markings - HOD Main Street vehicular paver
- Loading zone/parking space markings - HOD Main Street impressed preformed thermoplastic
- Sidewalk - brick paver
- Sidewalk - concrete
- Sidewalk - concrete pavers

Legend:

-  Active Street Type 1
-  Active Street Type 2
-  Active Street Type 3
-  HOD Streetscape Standard
-  Other Standard

INTERSECTION - HOD MAIN STREET VEHICULAR BRICK PAVER

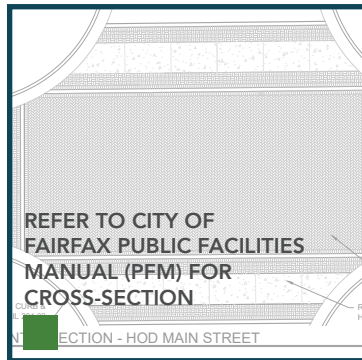

INTERSECTION - HOD MAIN STREET IMPRESSED PREFORMED THERMOPLASTIC/ASPHALT

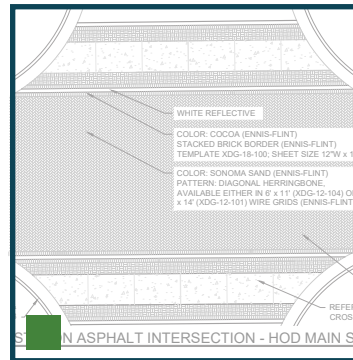

LOADING ZONE/PARKING SPACE MARKINGS

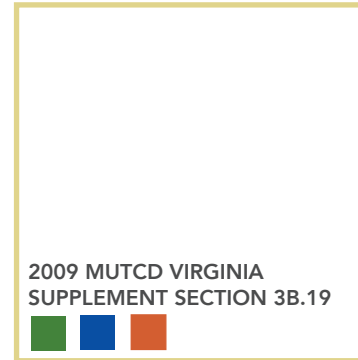

LOADING ZONE/PARKING SPACE MARKINGS - HOD MAIN STREET VEHICULAR BRICK PAVER

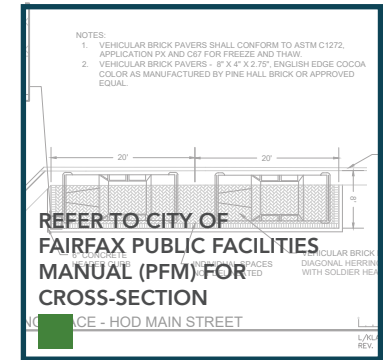

LOADING ZONE/PARKING SPACE MARKINGS - HOD MAIN ST IMPRESSED PREFORMED THERMOPLASTIC

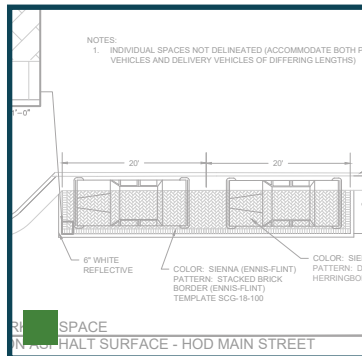

SIDEWALK - BRICK PAVERS



SIDEWALK - CONCRETE

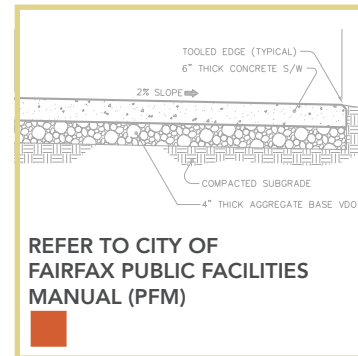

SIDEWALK - CONCRETE PAVERS

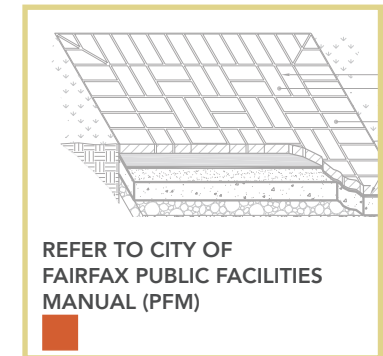

Streetscape Elements

BULB OUT

Description

Widened sidewalks at intersections to enhance pedestrian safety and to provide additional space for street furnishings, plantings, and stormwater infiltration

Style

- Respond in brick pattern to existing sidewalk patterns and colors

Size

- Radius 25'

Materials and Color

- Brick color: To match the sidewalk color
- Concrete curb and gutter (VDOT Standard Detail CG-6)

Location and Setbacks

- Intersections where space exists, pedestrian demand supports and traffic modeling supports implementation

Requirements

- Pedestrian demand or need
- Traffic modeling supports insertion

Source

Glen-Gery Brick or equal
<https://www.glengery.com>



Bulb outs in the Town of Middleburg, VA

Streetscape Elements

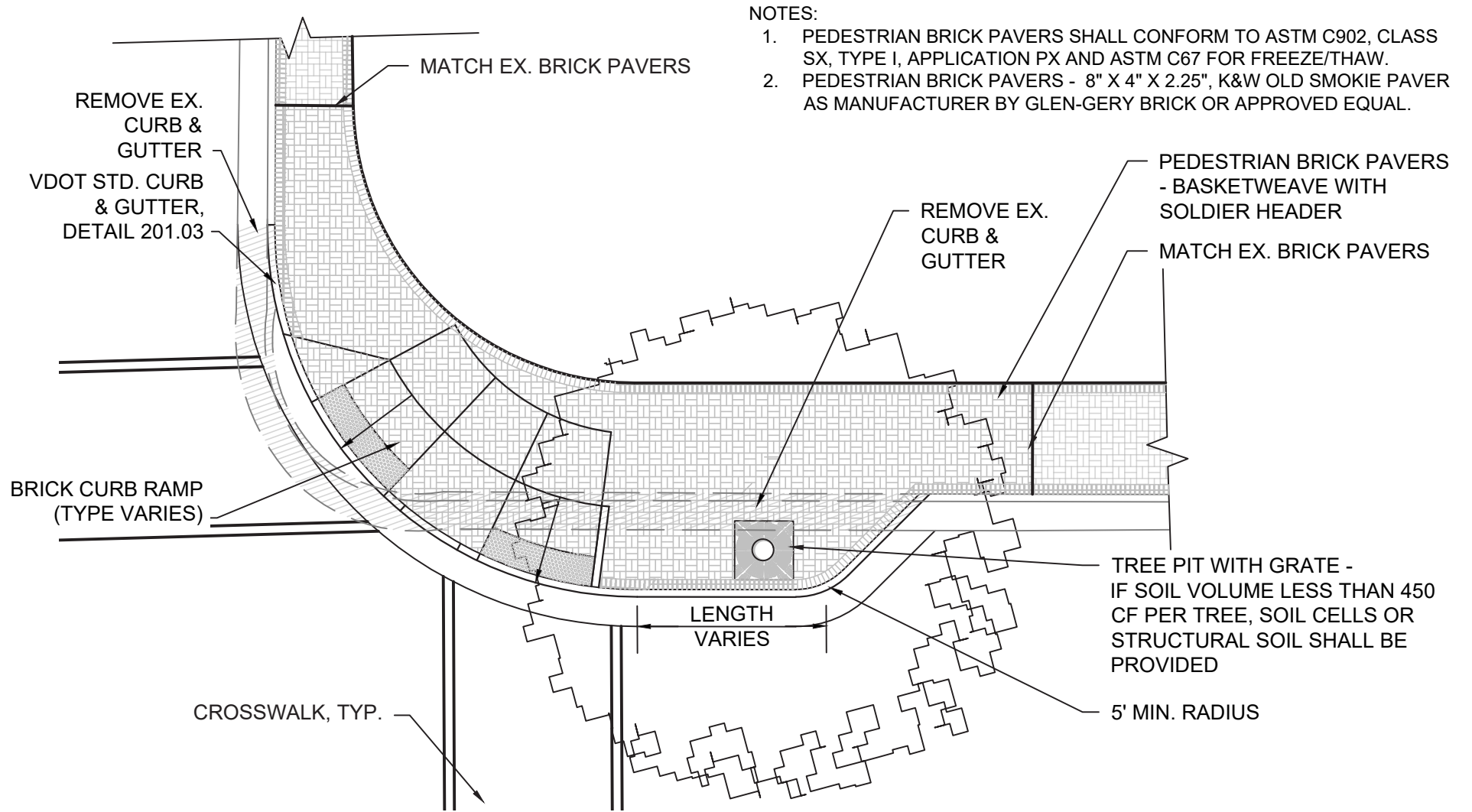

BULB OUT DETAIL

0 5 10 Feet
 L/KLA 12.10.18
 REV. 1.24.19, 4.18.19

Streetscape Elements

CROSSWALK - HOD - IMPRESSED PREFORMED THERMOPLASTIC ON ASPHALT SURFACE

Description

Pressed onto an asphalt base, the preformed thermoplastic layer is positioned on the non-stamped, prepared asphalt surface. Material is heated to embed anti-skid elements and then the selected pattern is stamped into the material and the top layer of asphalt. This is the standard for crosswalks within the HOD. In use for a number of years, the detail in these Standards defines the color and required stamps.

Style

- Diagonal herringbone pattern
- Edge treatment: string course on either side of an internal curb/edge restraint

Size

- Width per City standard for crosswalks

Materials and Color

- Ennis-Flint Traffic PatternsXD at 150-mil thickness
- Color: cocoa
- Stamp: diagonal herringbone with standard border as shown on detail

Location and Setbacks

- HOD Active Street Type 1 except when HOD Main Street crosswalk used instead
- HOD Active Street Type 2

Requirements

- Application to be done by Certified Applicator for Ennis-Flint

Source

Ennis-Flint or equal
<https://www.ennisflintamericas.com/>



Existing stamped asphalt crosswalk paving in City of Fairfax

Streetscape Elements

Color: Cocoa (Ennis-Flint)

Pattern: Diagonal Herringbone, available either in 6 foot x 11 foot (XDG-12-104) or 8 foot x 14 foot (XDG-12-101) wire grids; (Ennis-Flint)

Border: Standard Border - Soldier Course Straight in 12'2"W x 1'7"L (XDG-18-1-199) wire grids; (Ennis-Flint stamp)

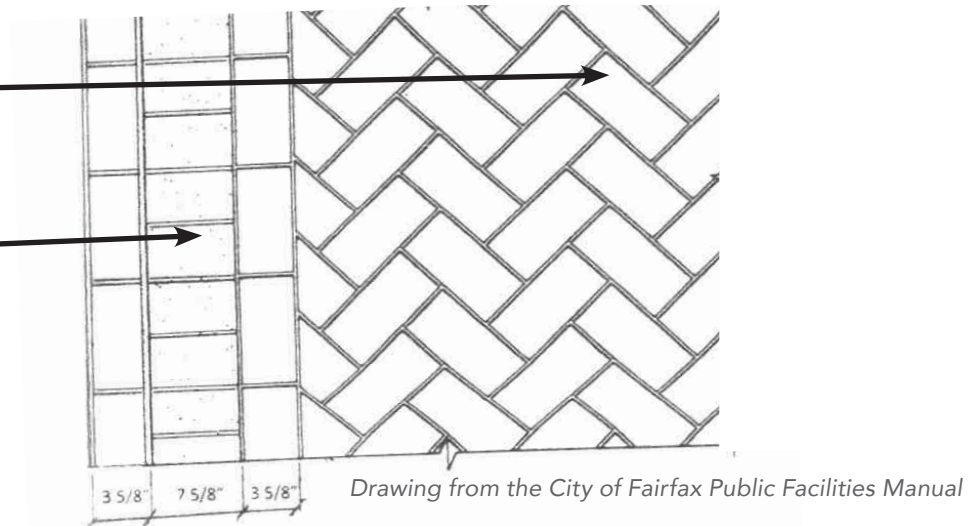

CROSSWALK - HOD - IMPRESSED PREFORMED THERMOPLASTIC ON ASPHALT SURFACE

Streetscape Elements

CROSSWALK - HOD MAIN STREET - VEHICULAR BRICK PAVER

Description

- Specific crosswalks within the HOD may be suitable for use of a special pattern, color, and material that reinforces the historic and pedestrian character of the HOD

Style

- Suitable and sensitive to the surrounding building vocabulary within the HOD

Size

- Crosswalk as dimensioned in detail
- Pavers 8 inches x 4 inches x 2.75 inches

Materials and Color

- Vehicular brick pavers for border - Pine Hall English Edge Full Range
- Concrete walk within crosswalk - Davis Color #5237

Location and Setbacks

- HOD Active Street Type 1 - Main Street and its intersections between East and West Streets

Requirements

- Meet visibility standards
- Vehicular brick pavers to conform to ASTM C1272, Application PX and C67 for freeze and thaw

Source

Pine Hall Brick or equal
<https://www.pinehallbrick.com>

Note

Concrete pavers maybe used in lieu of vehicular brick pavers upon approval by City Staff

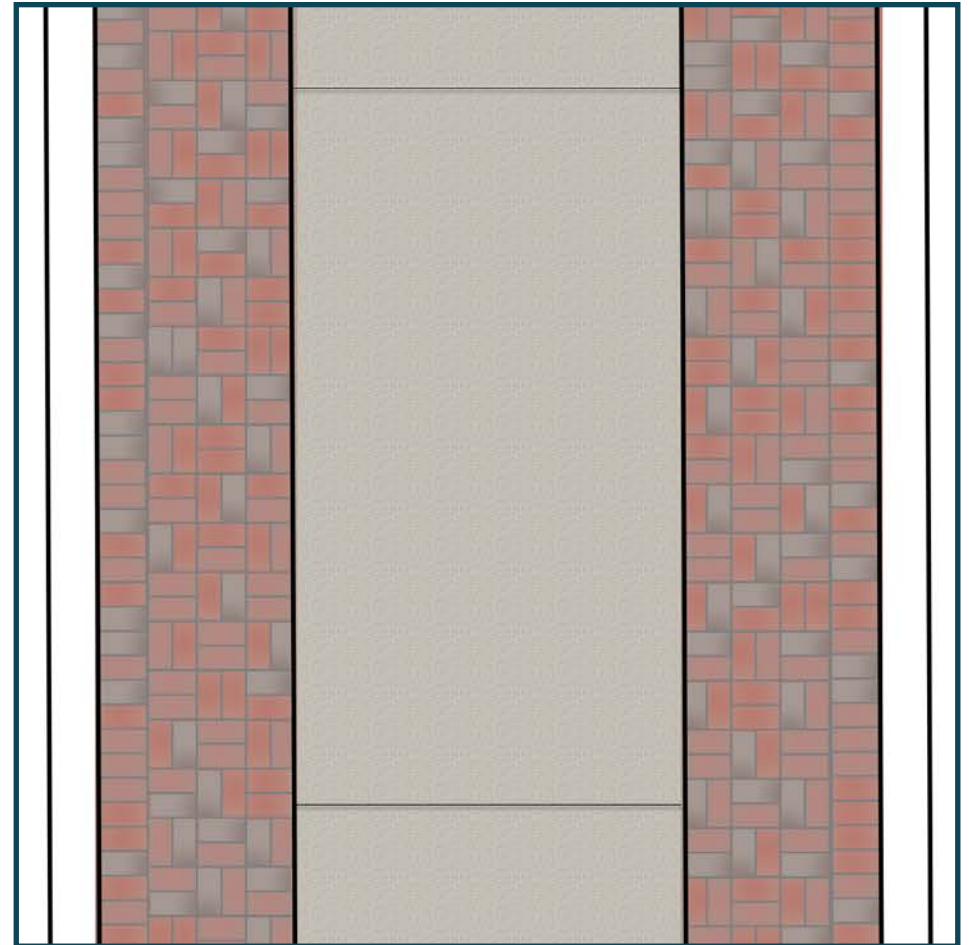
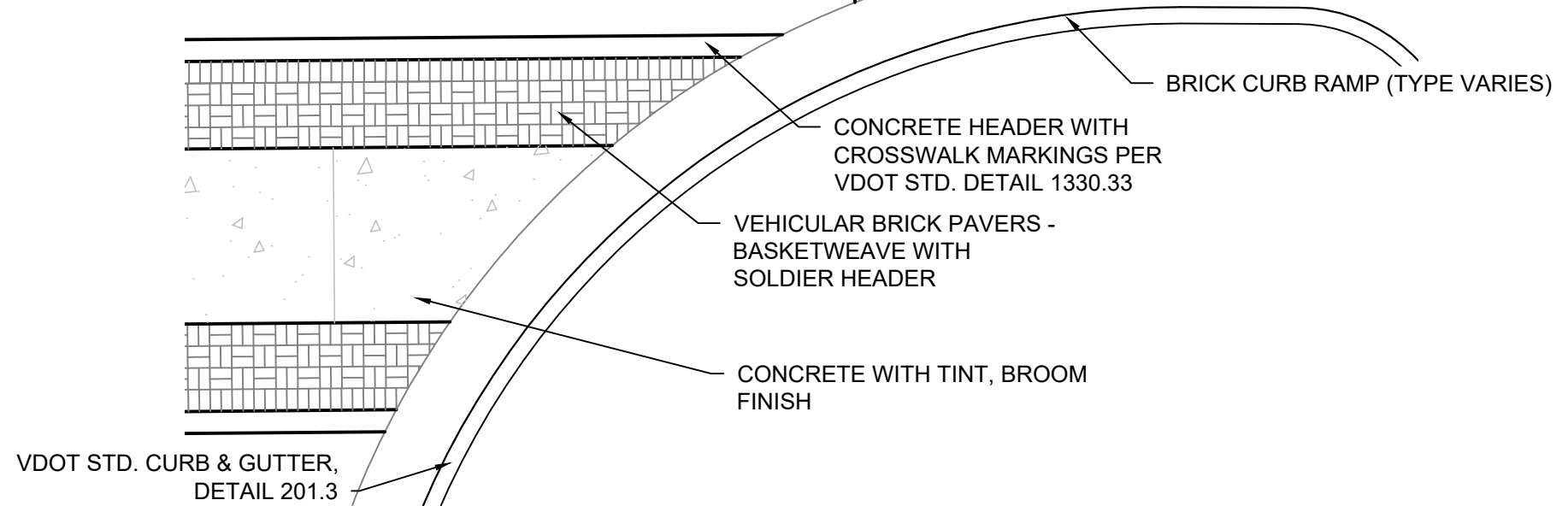
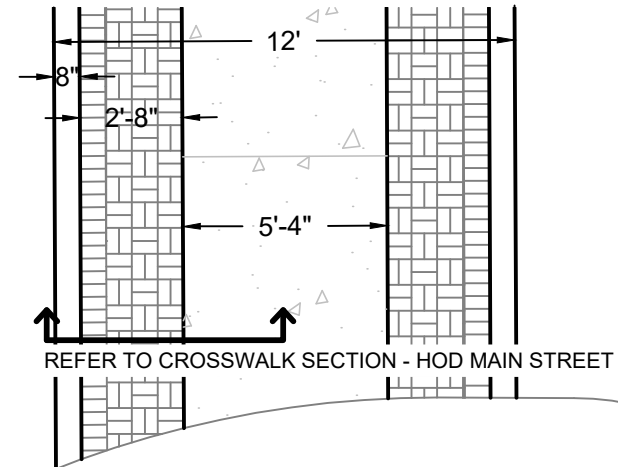

Illustration of proposed vehicular pavers and concrete for HOD Main Street crosswalk

Streetscape Elements

NOTES:

1. VEHICULAR BRICK PAVERS SHALL CONFORM TO ASTM C1272, APPLICATION PX AND C67 FOR FREEZE AND THAW.
2. VEHICULAR BRICK PAVERS - 8" X 4" X 2.75", ENGLISH EDGE FULL RANGE COLOR AS MANUFACTURED BY PINE HALL BRICK OR APPROVED EQUAL.
3. CONCRETE CROSSWALK PATH SHALL BE INTEGRALLY PIGMENTED - MATCH DAVIS COLORS #5237 OR APPROVED EQUAL.



CROSSWALK DETAIL - HOD MAIN STREET - VEHICULAR BRICK PAVER

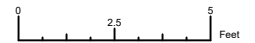

Note

Concrete pavers maybe used in lieu of vehicular brick pavers upon approval by City Staff

L/KLA 12.11.18
REV. 1.24.19, 4.8.19

Streetscape Elements

CROSSWALK - HOD MAIN STREET - IMPRESSED PREFORMED THERMOPLASTIC ON ASPHALT SURFACE

Description

Pressed onto an asphalt base, the preformed thermoplastic layer is positioned on the non-stamped, prepared asphalt surface. Material is heated to embed anti-skid elements and then the selected pattern is stamped into the material and the top layer of asphalt.

Style

- Special crosswalk treatment for key intersections on Main Street

Size

- Crosswalk as dimensioned in detail

Materials and Color

- Ennis-Flint Traffic PatternsXD® at 150-mil thickness
- Center of crosswalk thermoplastic; color - sand
- Walk bounded by impressed preformed thermoplastic border patterns: basketweave and stacked bound; color - cocoa

Location and Setbacks

- HOD Active Street Type 1 - Main Street and its intersections between East and West Streets

Requirements

- Per visibility standards
- Application to be done by Certified Applicator for Ennis-Flint

Source

Ennis-Flint or approved equal
<https://www.ennisflintamericas.com/>



TrafficPatternsXD® installed Danville, CA, multi-color and texture

Photo Credit: Ennis-Flint

Streetscape Elements

NOTES:

1. ENNIS-FLINT TRAFFIC PATTERNS - XD
THERMOPLASTIC CROSSWALK FOR ASPHALT
2. 150-MIL THICKNESS
3. APPLICATION BY CERTIFIED APPLICATOR

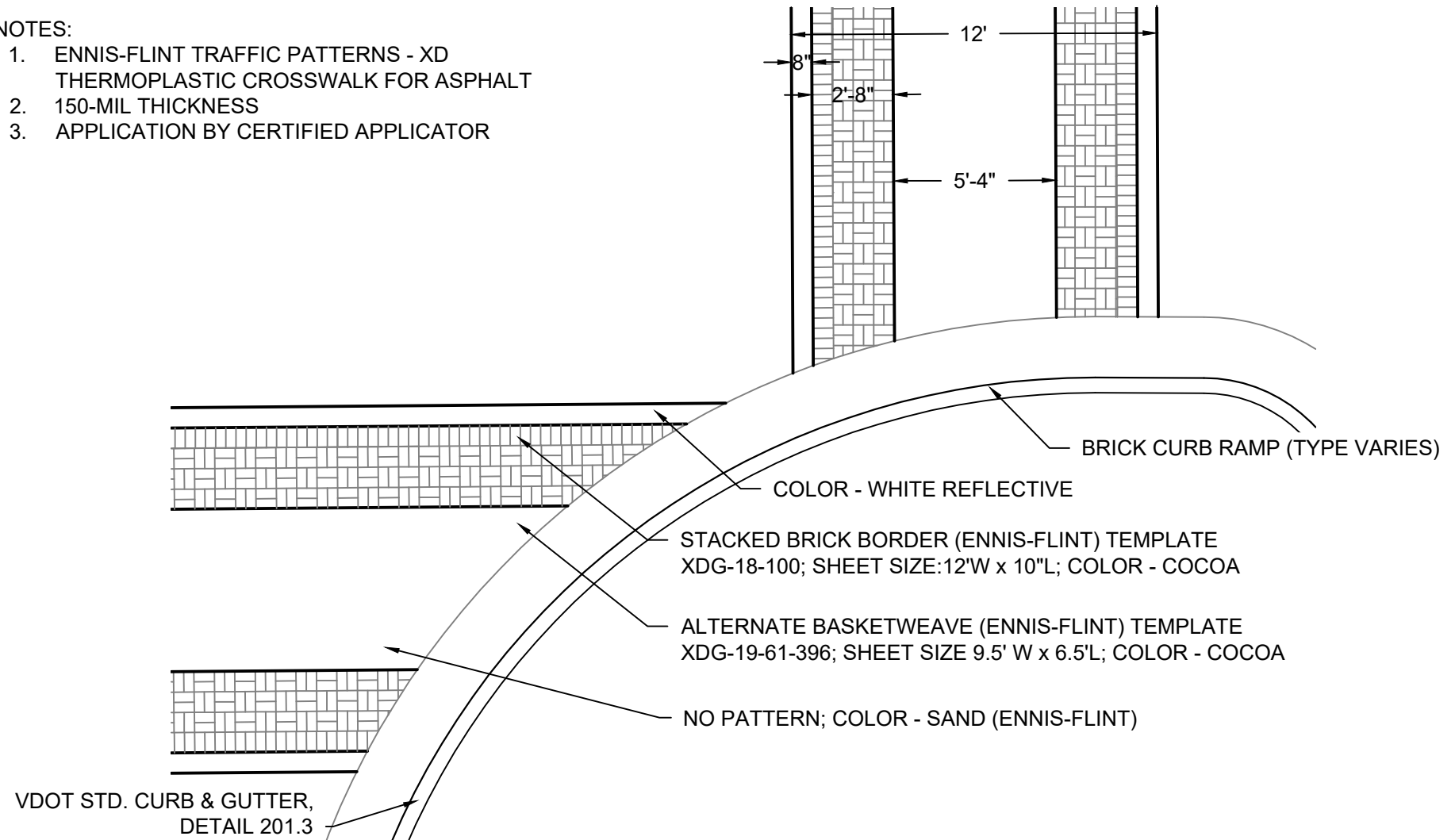

CROSSWALK DETAIL - HOD MAIN STREET - IMPRESSED PREFORMED THERMOPLASTIC ON ASPHALT

0 2.5 5 Feet
L/KLA 12.11.18
REV. 1.24.19, 4.8.19

Streetscape Elements

CURB RAMP - BRICK

Description

Curb ramps located on brick paver sidewalks and within the HOD can be paved with brick, allowing appropriate space for the required dome tiles per regulations.

Style

- Brick pavers with paving pattern to match existing sidewalk basket weave/parquet City of Fairfax Public Facilities Manual (PFM)

Size

- Size will vary dependent upon space available and required grades

Materials and Color

- Match to the surrounding brick paver size, color, and pattern
- City sidewalk standard: Old Smokie by Glen-Gery

Location and Setbacks

- Street Types 1 and 2

Requirements

- Adhere to ADAAG Public Rights-of-way guidance

Source

Glen-Gery Brick or equal
<https://www.glengery.com>



Brick curb ramp

Streetscape Elements

NOTES:

1. PEDESTRIAN BRICK SHALL CONFORM TO ASTM C902, CLASS SX, TYPE I, APPLICATION PX AND ASTM C67 FOR FREEZE/THAW.
2. PEDESTRIAN BRICK PAVERS - 8' X 4" X 2.25", K&W OLD SMOKIE PAVER AS MANUFACTURED BY GLEN-GERY BRICK OR APPROVED EQUAL.
3. TRUNCATED DOME ADA PAVERS SHALL COMPLY WITH THE ADA REQUIREMENT FOR DETECTABLE WARNING FOR USE IN THE PUBLIC ROW ACCORDING TO R304 GUIDELINES.
4. TRUNCATED DOME ADA PAVERS - 8' X 4" X 2.25", DARK ACCENT COLOR AS MANUFACTURED BY PINE HALL BRICK OR APPROVED EQUAL.

*RAMP FLARE AT 10:1 IF MIN. 4' LEVEL LANDING IS PROVIDED AT THE TOP OF THE RAMP. IF 4' MIN. LANDING CANNOT BE ACHIEVED, FLARE SHOULD HAVE A MAX. SLOPE OF 12:1.

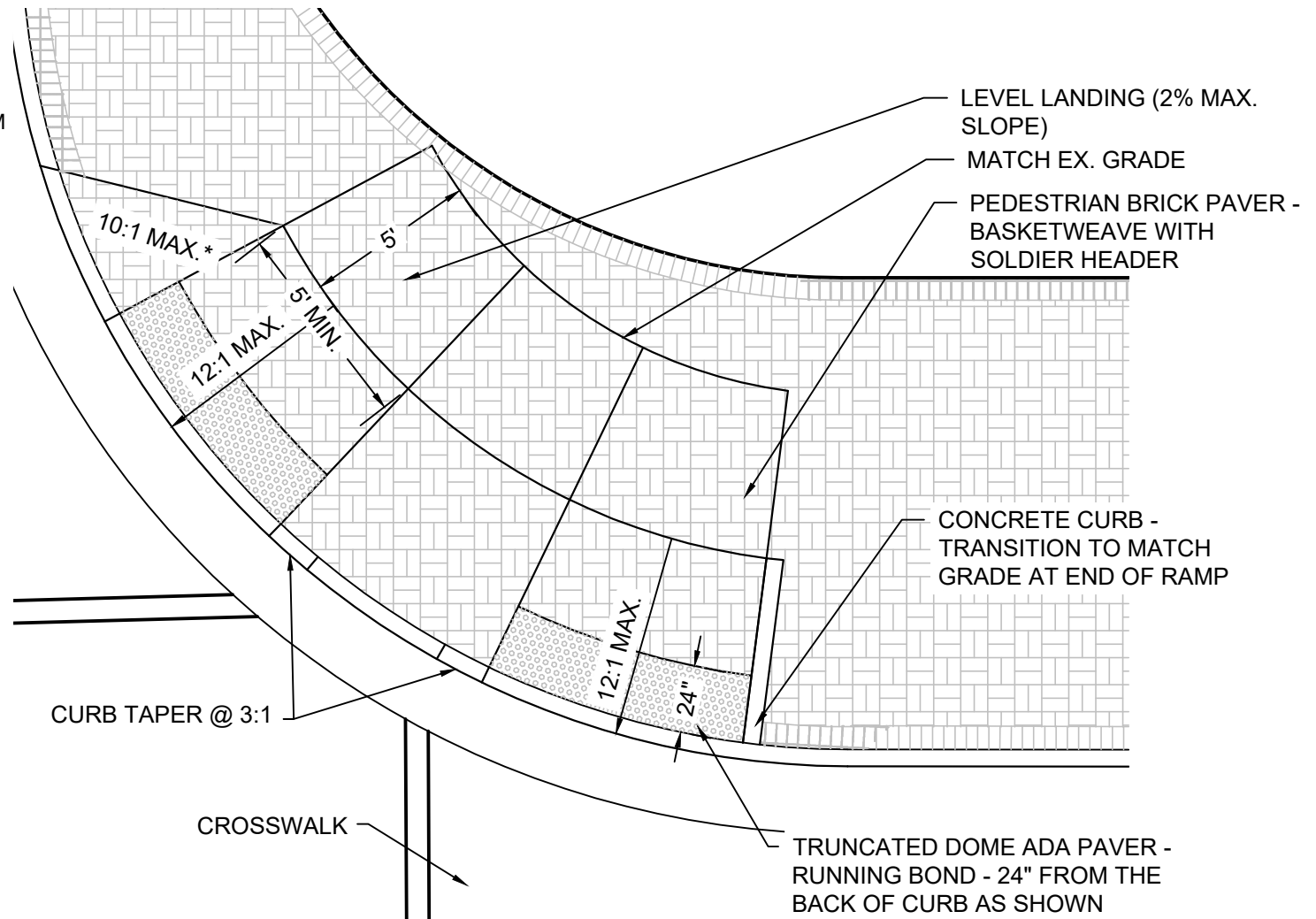

CURB RAMP - BRICK OPTION A

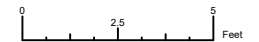

L/KLA 12.10.18
REV. 1.24.19, 4.18.19

Streetscape Elements

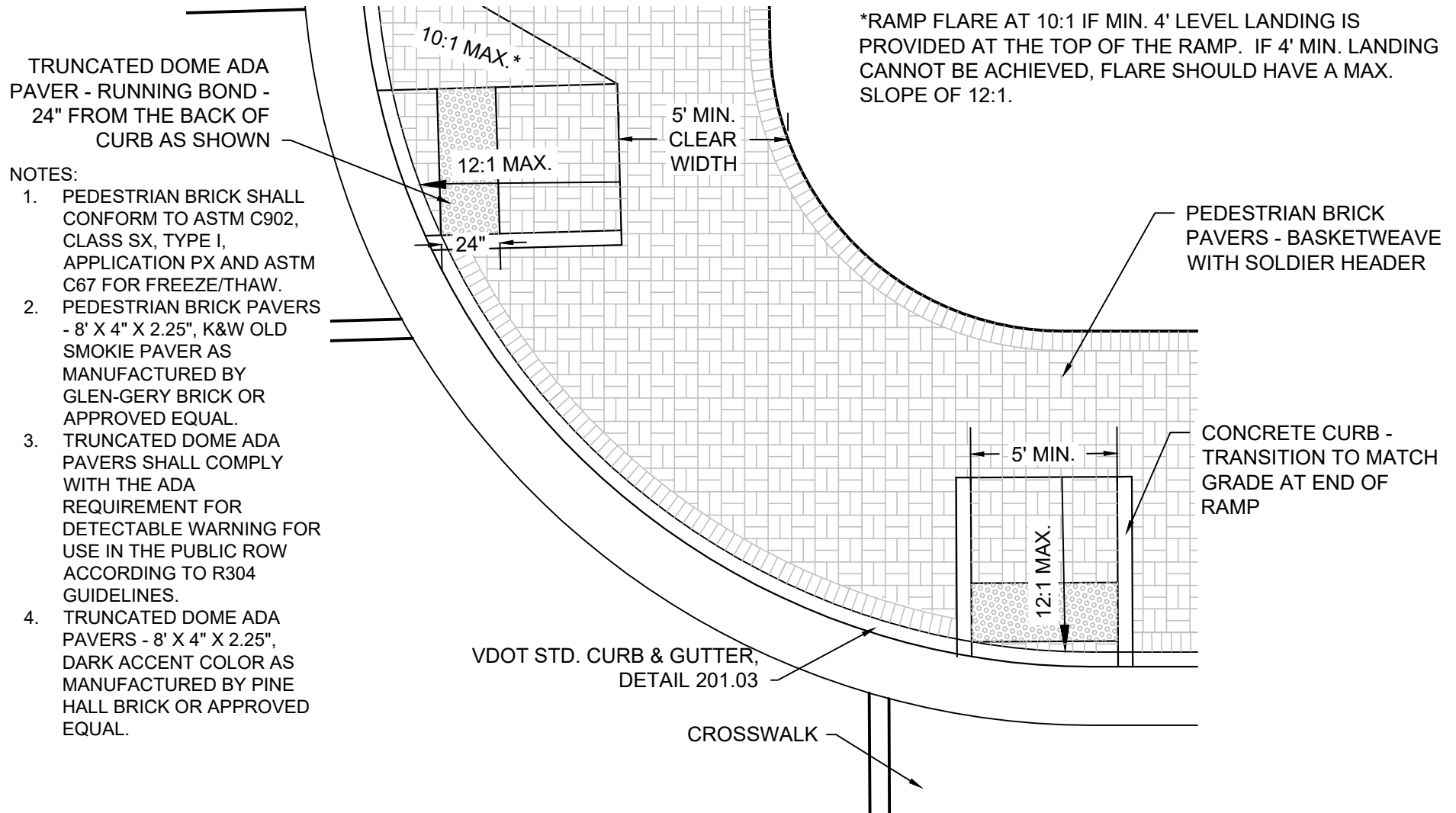

CURB RAMP - BRICK OPTION B

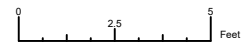

L/KLA 12.10.18
REV. 4.5.19, 4.18.19

Streetscape Elements

NOTES:

1. PEDESTRIAN BRICK SHALL CONFORM TO ASTM C902, CLASS SX, TYPE I, APPLICATION PX AND ASTM C67 FOR FREEZE/THAW.
2. PEDESTRIAN BRICK PAVERS - 8' X 4" X 2.25", K&W OLD SMOKIE PAVER AS MANUFACTURED BY GLEN-GERY BRICK OR APPROVED EQUAL.
3. TRUNCATED DOME ADA PAVERS SHALL COMPLY WITH THE ADA REQUIREMENT FOR DETECTABLE WARNING FOR USE IN THE PUBLIC ROW ACCORDING TO R304 GUIDELINES.
4. TRUNCATED DOME ADA PAVERS - 8' X 4" X 2.25", DARK ACCENT COLOR AS MANUFACTURED BY PINE HALL BRICK OR APPROVED EQUAL.

*RAMP FLARE AT 10:1 IF MIN. 4' LEVEL LANDING IS PROVIDED AT THE TOP OF THE RAMP. IF 4' MIN. LANDING CANNOT BE ACHIEVED, FLARE SHOULD HAVE A MAX. SLOPE OF 12:1.

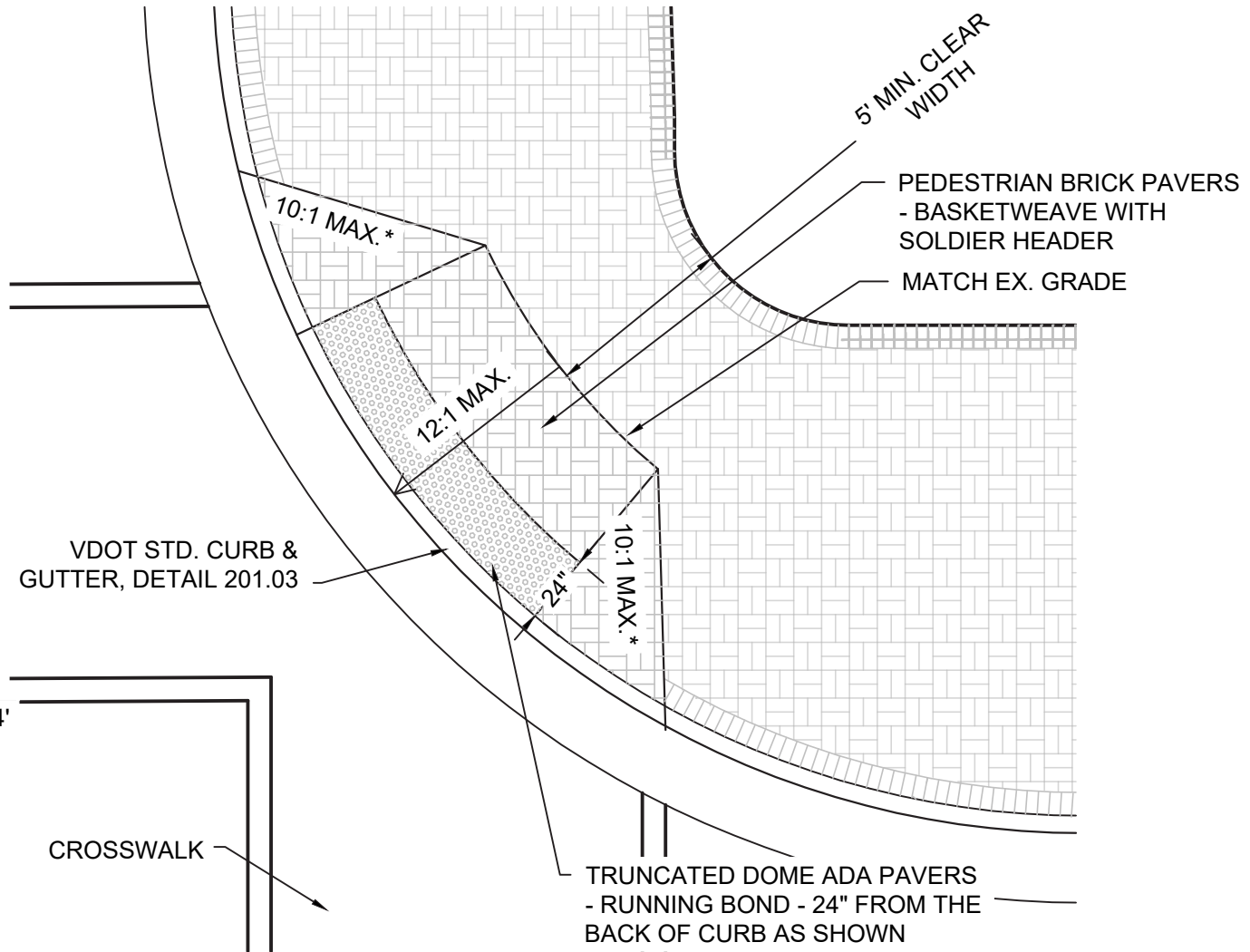

CURB RAMP - BRICK OPTION C

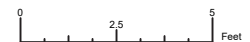

L/KLA 12.10.18
REV. 1.24.19, 4.18.19

Streetscape Elements

INTERSECTION - HOD MAIN STREET VEHICULAR BRICK PAVER

Description

This detail is applicable where special paving is called for within the center of an intersection

Style

- Masonry vehicular pavers within bounds of crosswalks

Size

- Vehicular brick paver 8 inch x 4 inch x 2.75 inches

Materials and Color

- Pine Hall Brick vehicular brick paver color English Edge Cocoa
- Intersection pattern - diagonal herringbone with soldier header

Location and Setbacks

- Active Street Type 1, University Drive and Main Street

Requirements

- Vehicular paver to conform to ASTM C1272 application PX and C67 for freeze and thaw

Source

Pine Hall Brick or equal
<https://www.pinehallbrick.com>

Note

Concrete pavers maybe used in lieu of vehicular brick pavers upon approval by City Staff

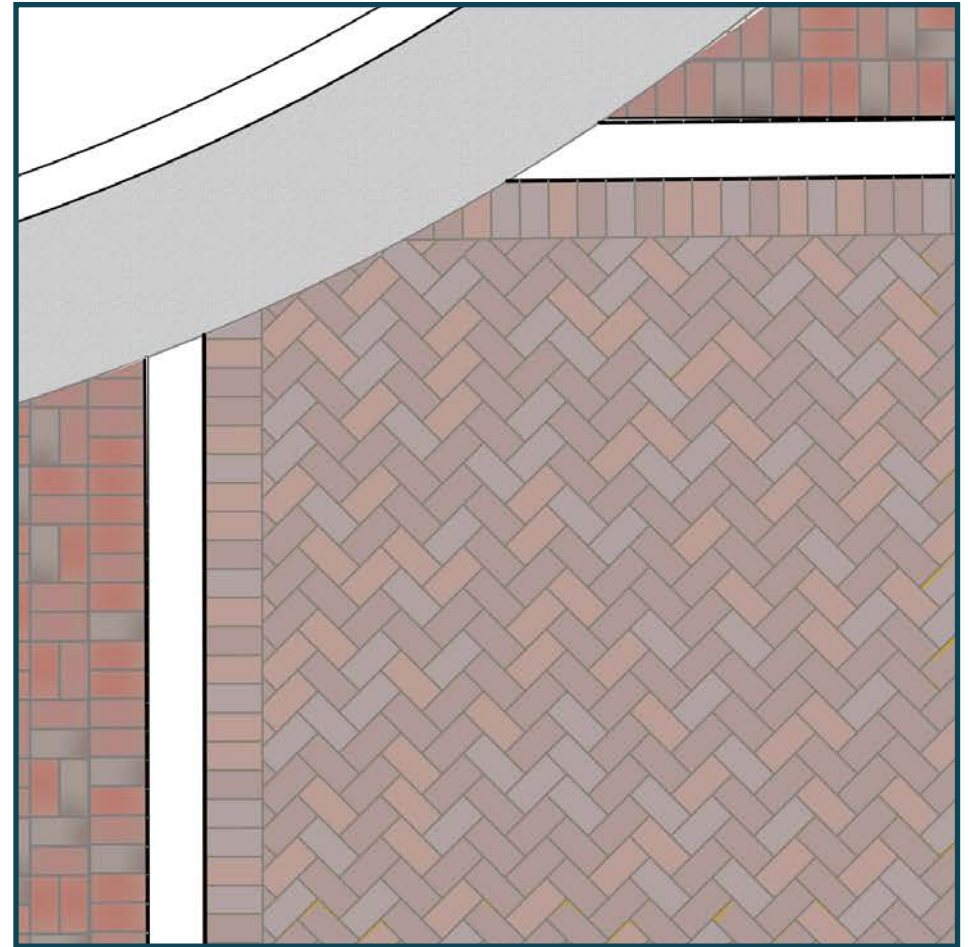
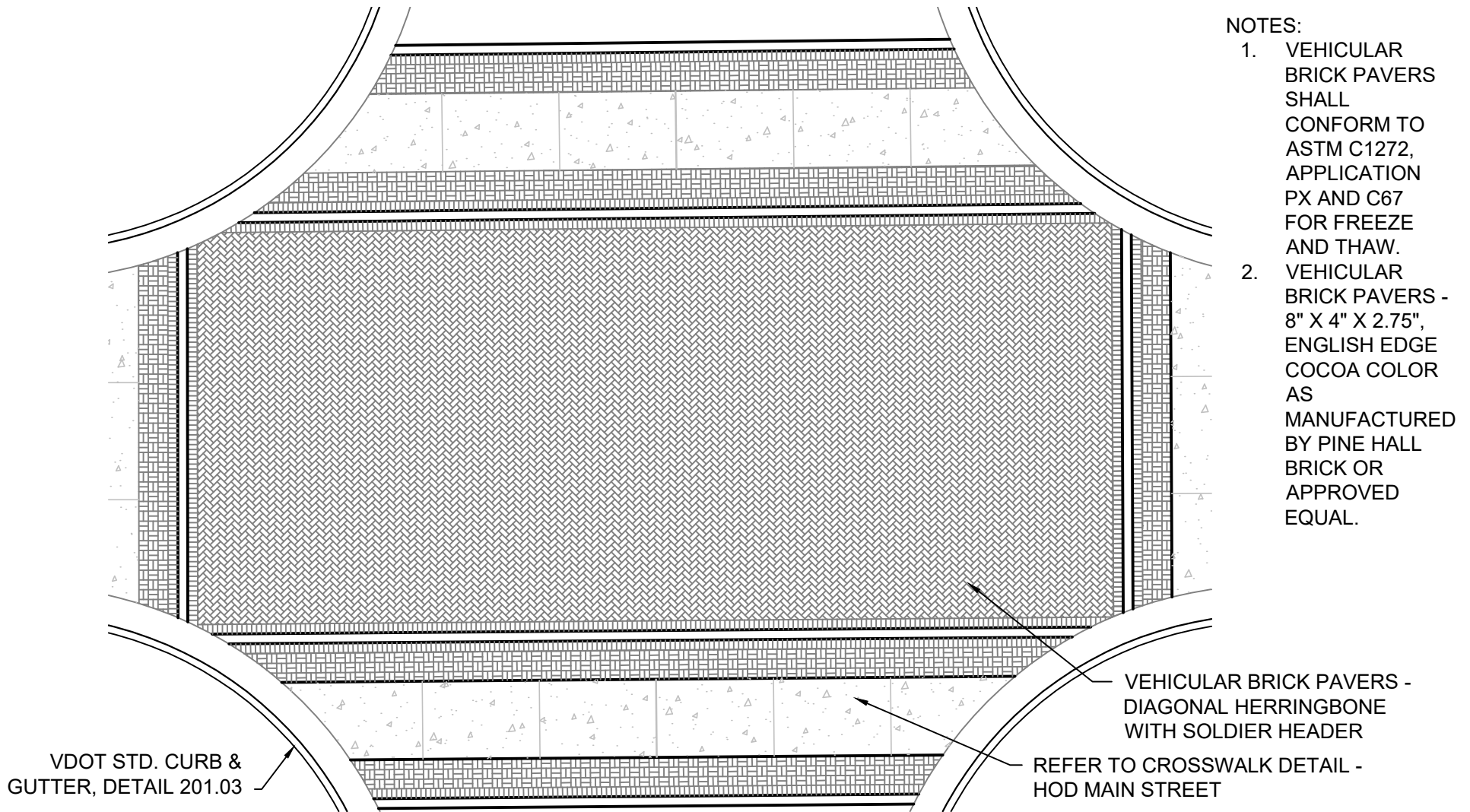

Illustration of proposed vehicular pavers for HOD Main Street intersection paving

Streetscape Elements



INTERSECTION - HOD MAIN STREET VEHICULAR BRICK PAVER



Note

Concrete pavers maybe used in lieu of vehicular brick pavers upon approval by City Staff

L/KLA 12.11.18
REV. 1.24.19, 4.8.19

Streetscape Elements

INTERSECTION - HOD MAIN STREET IMPRESSED PREFORMED THERMOPLASTIC ON ASPHALT SURFACE

Description

This detail is applicable where special paving is called for within the center of an intersection. Pressed onto an asphalt base, the preformed thermoplastic layer is positioned on the non-stamped, prepared asphalt surface. Material is heated to embed anti-skid elements and then the selected pattern is stamped into the material and the top layer of asphalt.

Style

- Diagonal herringbone pattern
- Edge treatment: string course on either side of an internal curb/edge restraint

Size

- Full intersection

Materials and Color

- Ennis-Flint Traffic PatternsXD® at 150-mil thickness
- Color and pattern per detail

Location and Setbacks

- Active Street Type 1, University Drive and Main Street

Requirements

- Application to be done by Certified Applicator for Ennis-Flint

Source

Ennis-Flint or approved equal
<https://www.ennisflintamericas.com>



TrafficPatternsXD® installed on Broad Street, Philadelphia, diagonal herringbone pattern

Photo Credit: Ennis-Flint

Streetscape Elements

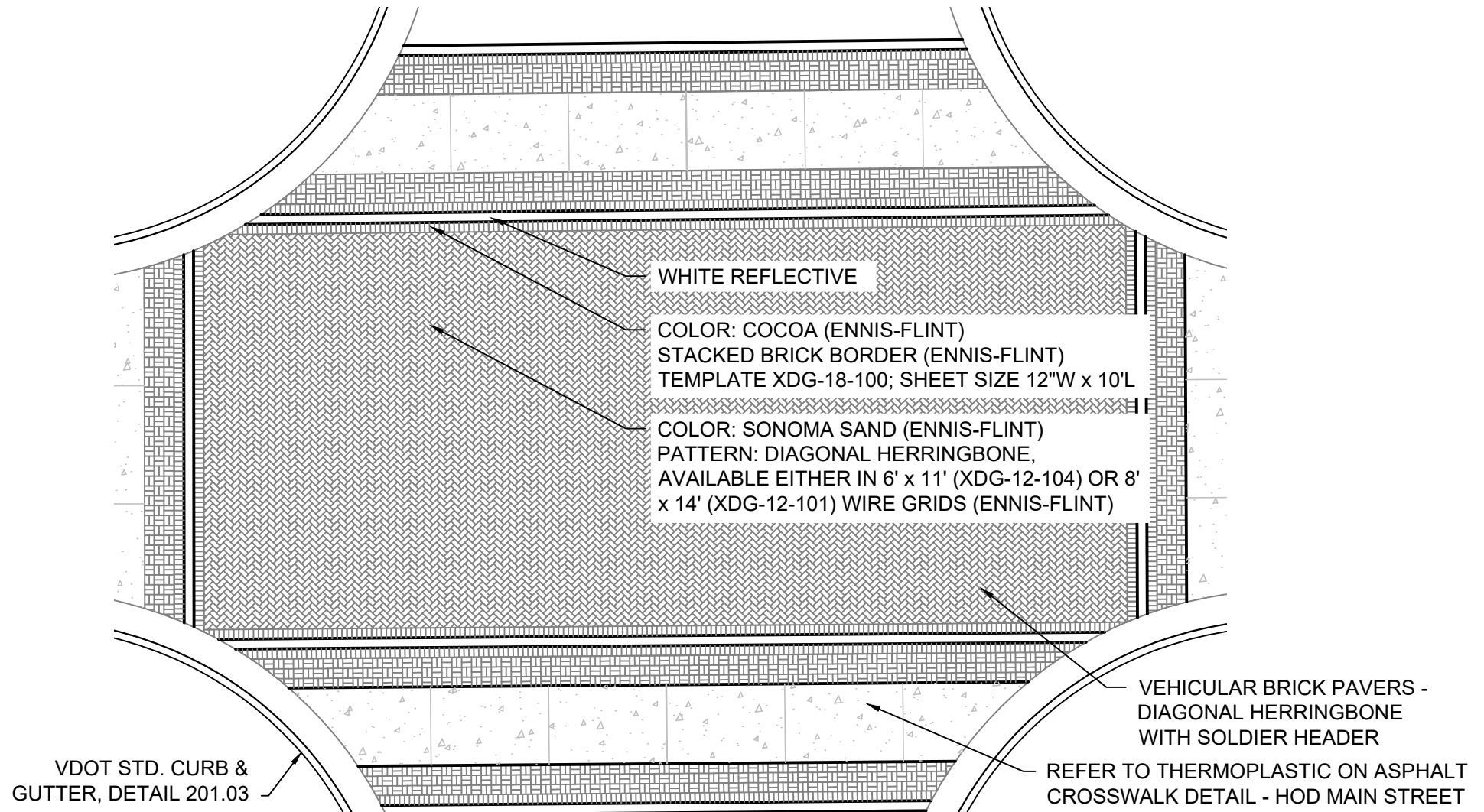

INTERSECTION - HOD MAIN STREET IMPRESSED PREFORMED THERMOPLASTIC ON ASPHALT SURFACE

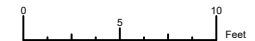

L/KLA 12.11.18
 REV. 1.24.19, 4.8.19

Streetscape Elements

LOADING ZONE/PARKING SPACE MARKINGS - HOD MAIN STREET VEHICULAR BRICK PAVER

Description

In very specific locations, most commonly located along Main Street and University Drive, loading zones may be marked with paving stones, bricks, or paint to distinguish the zone from the travel and turn lanes of the street.

Style

- Masonry vehicular pavers

Size

- Vehicular brick paver 8 inch x 4 inch x 2.75 inches

Materials and Color

- Pine Hall Brick vehicular brick paver color English Edge Cocoa
- Pattern - diagonal herringbone with soldier header

Location and Setbacks

- On-street loading zones/parking spaces on Main Street and University Drive within the HOD

Requirements

- Vehicular paver to conform to ASTM C1272 application PX and C67 for freeze and thaw

Sources

Pine Hall Brick or equal
<https://www.pinehallbrick.com>

Note

Concrete pavers maybe used in lieu of vehicular brick pavers upon approval by City Staff

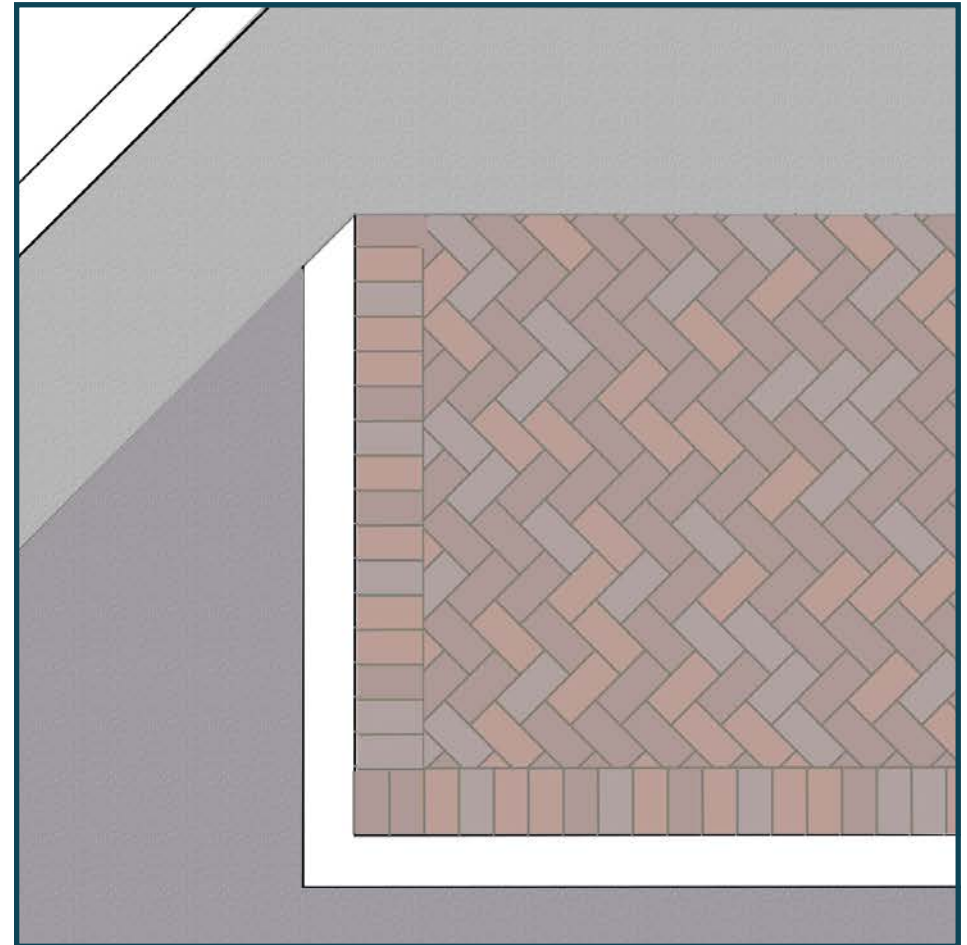
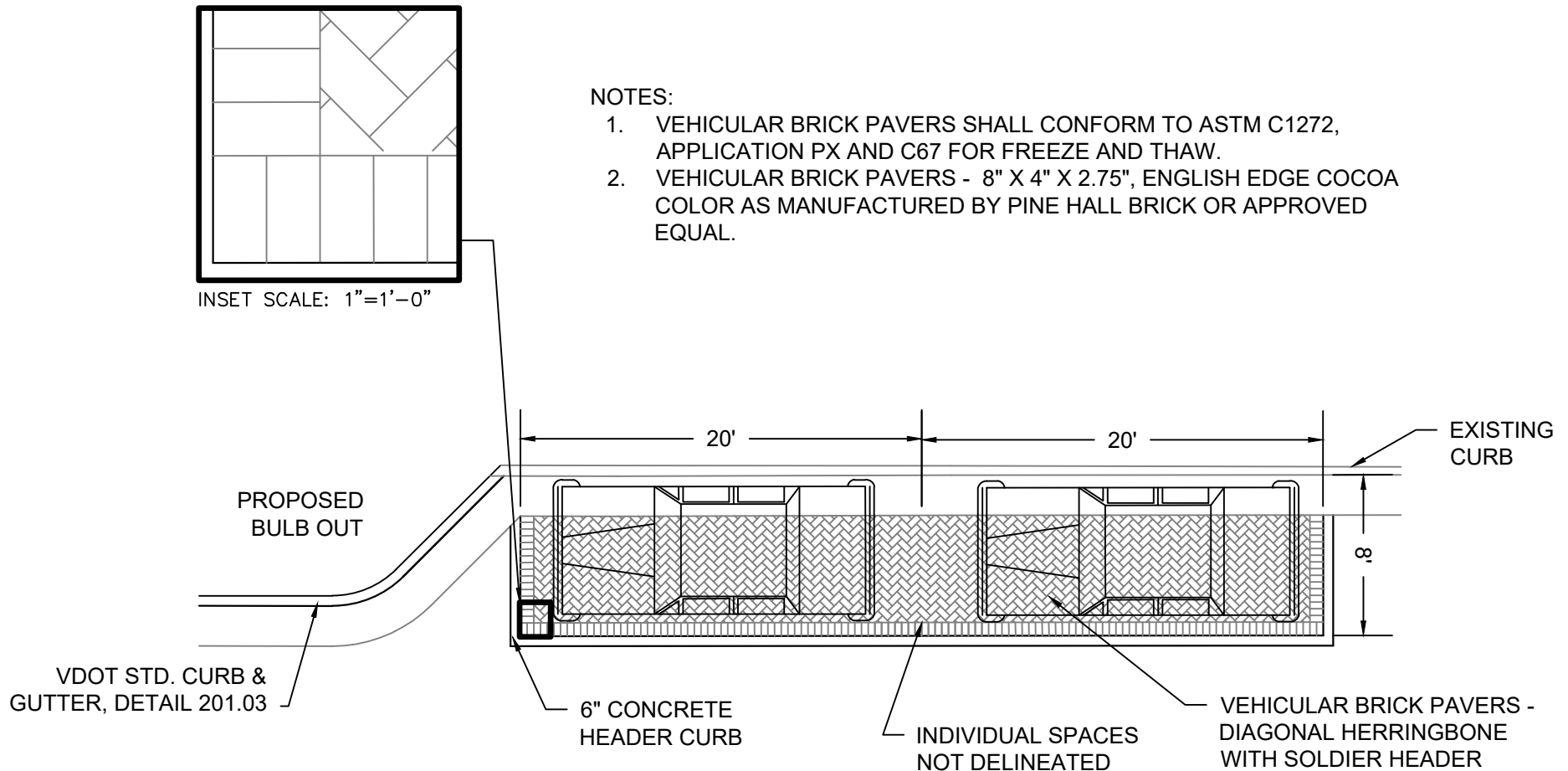

Illustration of proposed vehicular pavers for loading zone/parking space markings

Streetscape Elements



LOADING ZONE/PARKING SPACE - HOD MAIN STREET

VEHICULAR BRICK PAVER



L/KLA 12.11.18
REV. 1.24.19, 4.18.19

Note

Concrete pavers maybe used in lieu of vehicular brick pavers upon approval by City Staff

Streetscape Elements

LOADING ZONE/ PARKING SPACE MARKINGS - HOD MAIN STREET IMPRESSED PREFORMED THERMOPLASTIC ON ASPHALT SURFACE

Description

Pressed onto an asphalt base, the preformed thermoplastic layer is positioned on the non-stamped, prepared asphalt surface. Material is heated to embed anti-skid elements and then the selected pattern is stamped into the material and the top layer of asphalt.

Style

- Diagonal herringbone pattern
- Edge treatment: string course on either side of an internal curb/edge restraint

Size

- Individual spaces are not marked

Materials and Color

- Ennis-Flint Traffic PatternsXD® at 150-mil thickness
- Color: sienna
- Stamp: diagonal herringbone with standard border as shown on detail

Location and Setbacks

- Active Street Type 1 on Main Street between West and East Streets and University Drive
- Per City practice, individual spaces are not striped, all contiguous spaces contained within a white boundary edge

Requirements

- Adhere to ADA guidelines for accessible space provision, location, and dimensions
- 2009 MUTCD Virginia Supplement Section 3B.19
- Application to be done by Certified Applicator for Ennis-Flint

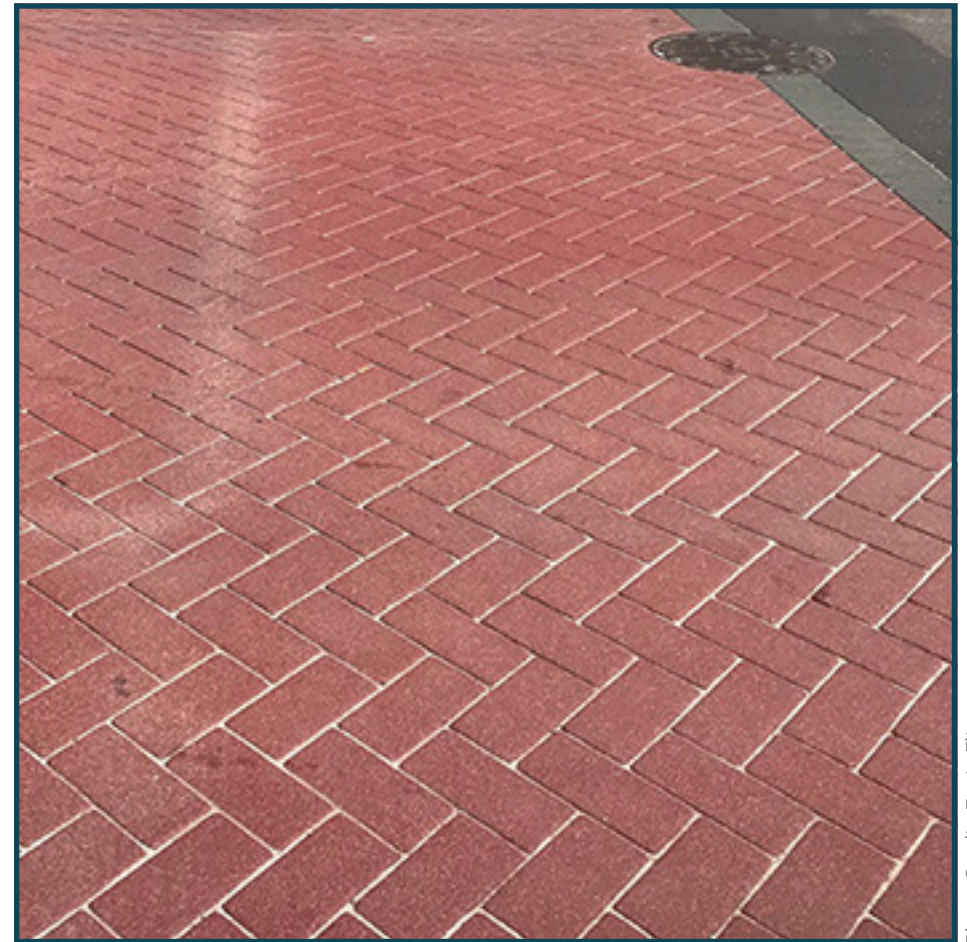

*TrafficPatternsXD® installed on Broad Street, Philadelphia,
diagonal herringbone pattern*

Photo Credit: Ennis-Flint

Sources

Ennis-Flint or approved equal
<https://www.ennisflintamericas.com>

Streetscape Elements

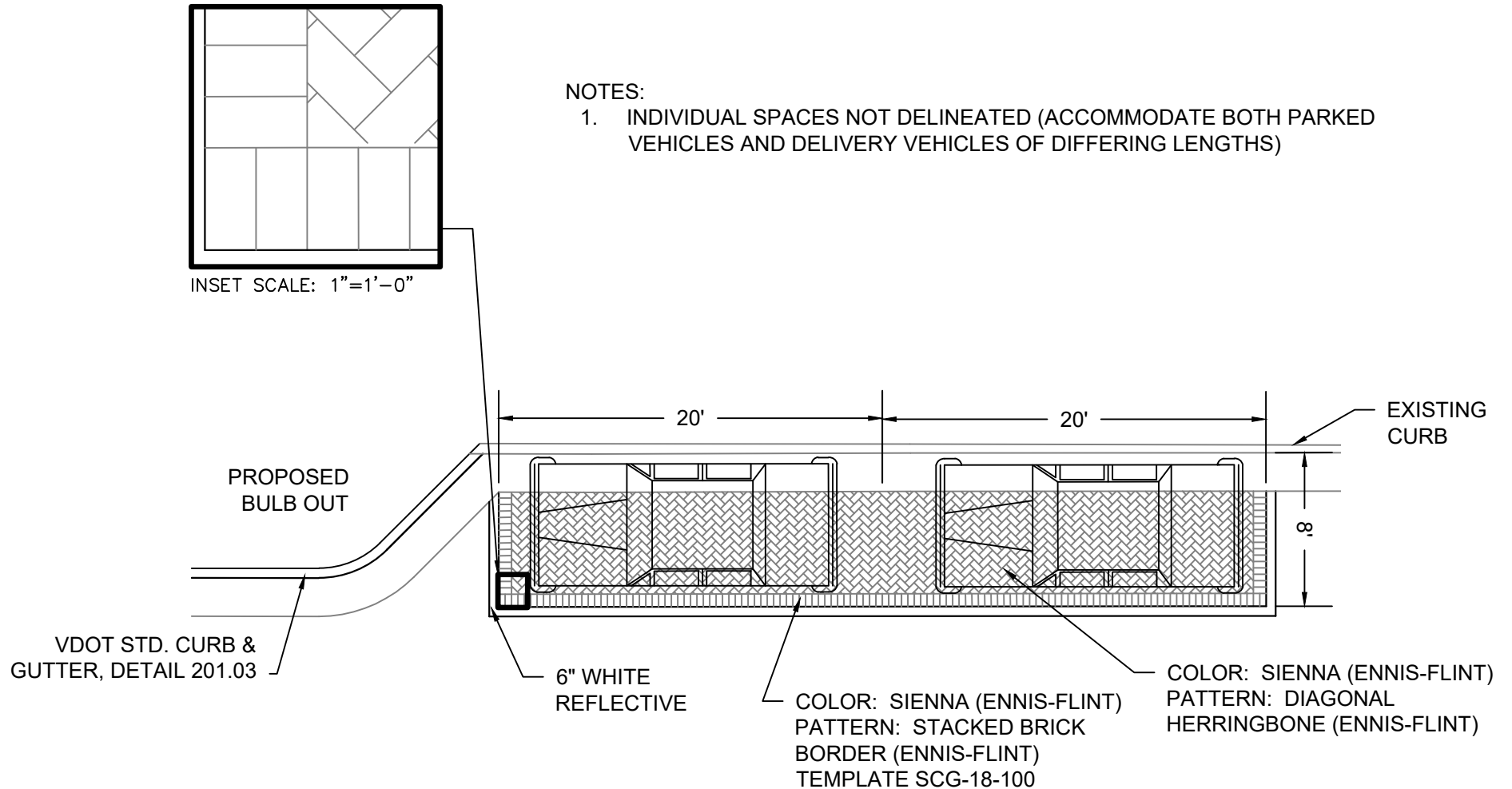

LOADING ZONE/PARKING SPACE - HOD MAIN STREET

IMPRESSED PREFORMED THERMOPLASTIC ON ASPHALT SURFACE



L/KLA 12.11.18
REV. 1.24.19, 4.18.19

Streetscape Elements

PLANTS

DIVISION MATRIX SHEET

- Planting Detail - Evergreen tree
- Planting Detail - Groundcover
- Planting Detail - Tree pit - Linear pit
- Planting Detail - Tree pit - Soil cells
- Planting Detail - Tree pit - Structural soil
- Planting Detail - Single-stem tree upright
- Planting Detail - Single-stem tree
- Planting Detail - Multi-stem
- Planting Detail - Shrub, Container and B&B
- Planting Detail - Plug
- Planting Detail - Standard tree protection
- Planting Detail - Root pruning

Legend:

- Active Street Type 1
- Active Street Type 2
- Active Street Type 3
- HOD Streetscape Standard
- Other Standard

PLANTING DETAIL - EVERGREEN TREE

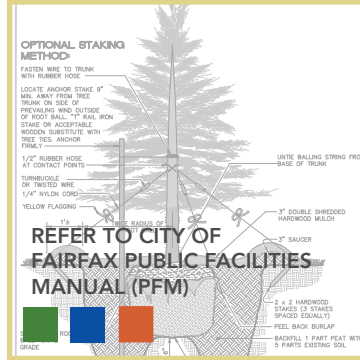

PLANTING DETAIL - GROUNDCOVER

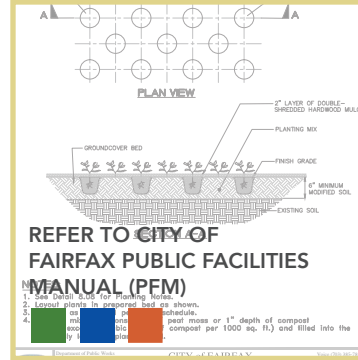

PLANTING DETAIL - TREE PIT - LINEAR PIT

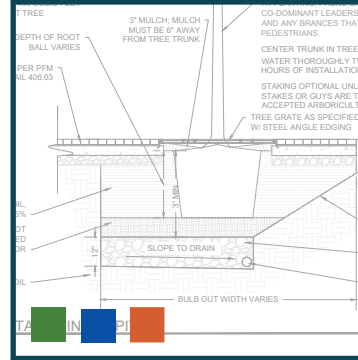

PLANTING DETAIL - TREE PIT - SOIL CELLS

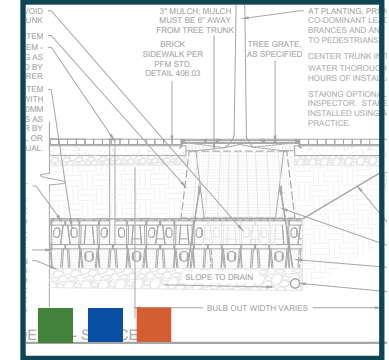

PLANTING DETAIL - TREE PIT - STRUCTURAL SOIL

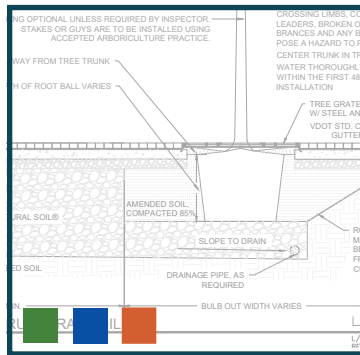

PLANT DETAIL - SINGLE STEM TREE UPRIGHT

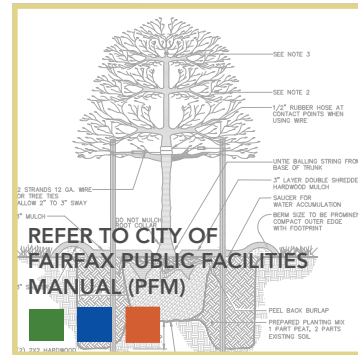

PLANTING DETAIL - SINGLE STEM TREE

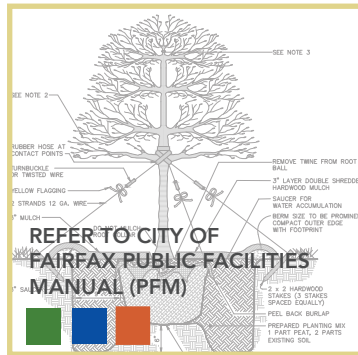

PLANTING DETAIL - MULTI-STEM TREE

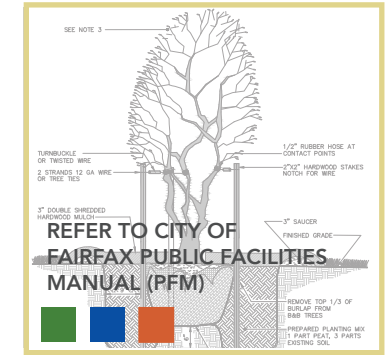

PLANTING DETAIL - SHRUB, CONTAINER AND B&B

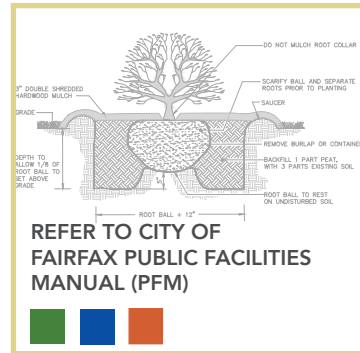

PLANTING DETAIL - PLUG

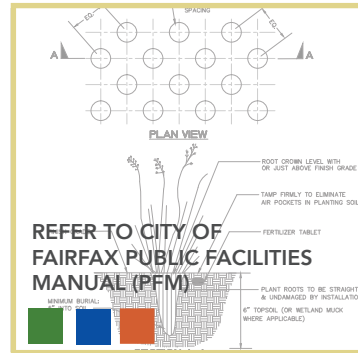

PLANTING DETAIL - STANDARD TREE PROTECTION

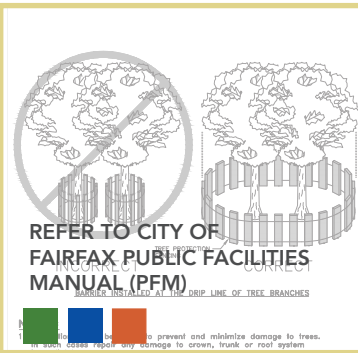

PLANTING DETAIL - ROOT PRUNING

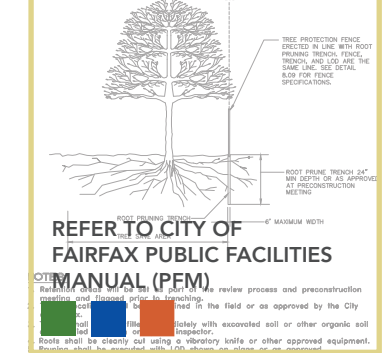

Streetscape Elements

PLANTS DIVISION MATRIX SHEET

- Plant List - Groundcovers
- Plant List - Hanging/hayrack basket
- Plant List - Planter pot
- Plant List - Shrubs
- Plant List - Additional Sources

PLANT LIST -
GROUNDCOVERS



PLANT LIST - HANGING/
HAYRACK BASKET



PLANT LIST - PLANTER
POT

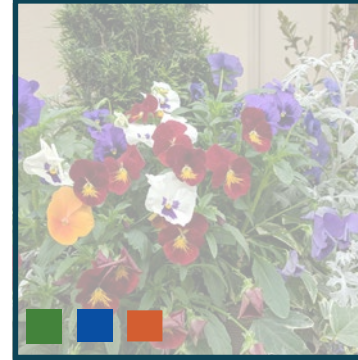

PLANT LIST - SHRUBS



ADDITIONAL SOURCES -
PLANT LISTS

REFER TO CITY OF FAIRFAX
DESIGN GUIDELINES FOR
PLANT LISTS FOR

- BIORETENTION
- SCREENING
- TRANSITIONAL YARDS
- URBAN STREET TREES
- UTILITY CORRIDORS
- VEGETATED WALLS



Legend:

Active Street Type 1



Active Street Type 2



Active Street Type 3



HOD Streetscape
Standard



Other Standard

Streetscape Elements

TREE PIT - LINEAR PIT

Description

Urban trees need access to greater soil volume than often was provided in earlier urban street tree plantings. One technique to expand the soil volume is to plant in a linear pit with the width of the pit varying between 6 and 8 feet wide and the length variable and dependent upon adjacent uses such as on-street curbside parking. The total cubic foot (cf) volume must provide 450 cf per tree if a single tree is planted and 350 cf per tree if multiple trees share a pit.

Size

- Pit width and length may vary, maximum depth of soil is 3 feet
- Provide a minimum of 450 cf of soil/tree, or 350 cf of soil each if two or more trees are planted in the same linear pit

Materials and Color

- The linear pit is only visible on its surface - surface treatments may vary from the use of a tree grate as pictured to the right, plantings, mulch, or other pervious material

Requirements

- Meet 3 foot maximum depth when calculating width and length of pit to achieve 450 cf/single tree or 350 cf/multiple tree
- Adhere to ADA guidelines for accessible space provision, location, and dimensions



Linear tree pit planting covered by tree grate

Photo Credit: Ironsmith

Streetscape Elements

NOTE: SOIL VOLUME 450 CUBIC FEET
MINIMUM PER STREET TREE

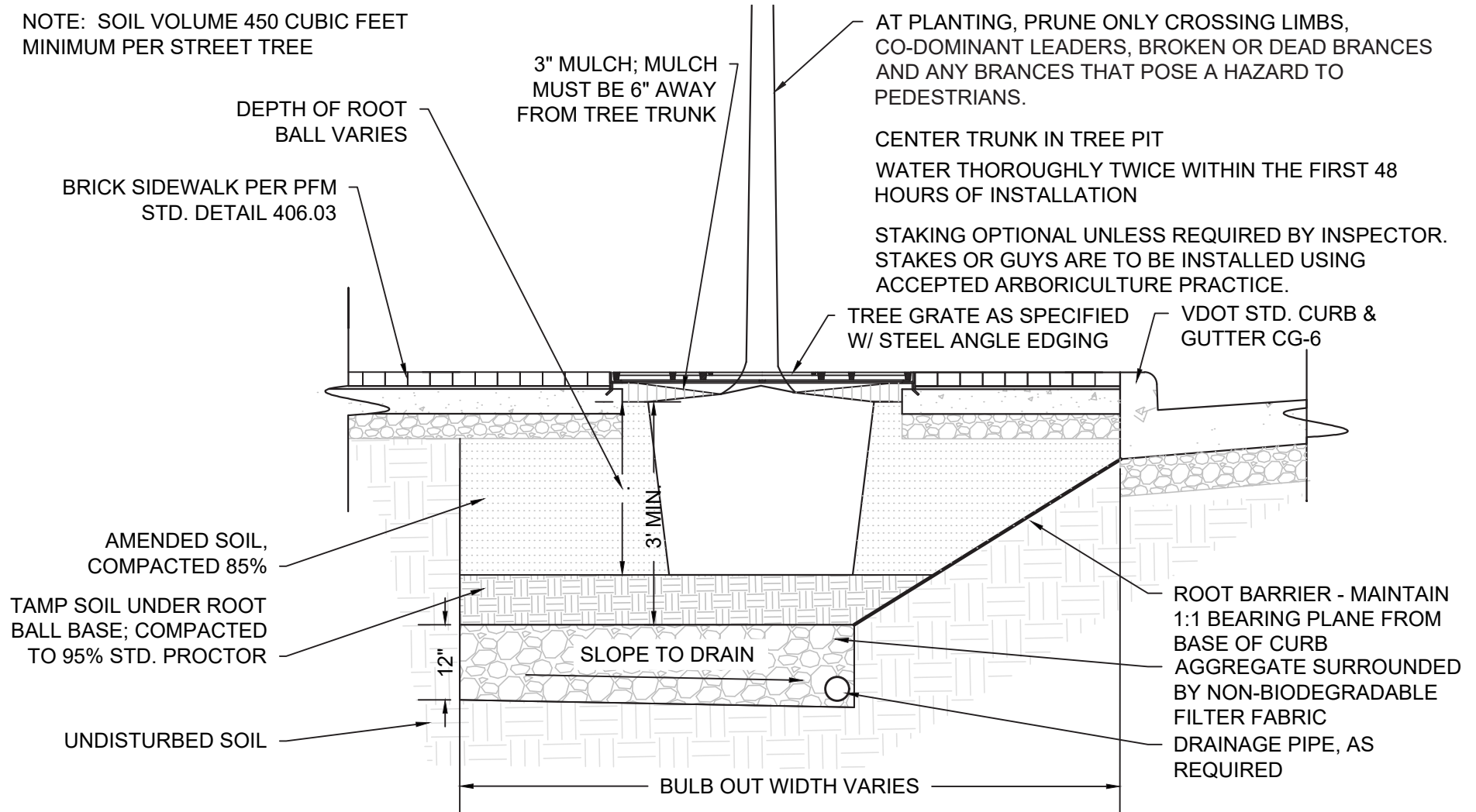

TREE PIT DETAIL - LINEAR PIT



L/KLA 12.11.18
REV. 1.24.19, 4.8.19

Streetscape Elements

TREE PIT - SOIL CELLS

Description

A modular system of load-bearing honeycomb structures (boxes, cells, spacers, or similar) placed under the pavement surface to provide structure and space for additional soil volume, the spread of tree roots, and stormwater treatment while supporting the sidewalk or surface pavement. If used for infiltration purposes, soil in structural soil cells must be a minimum of 30 inches of bioretention soil or per the manufacturer's specifications and must comply with other City standards and regulations for stormwater management.

Size

- Varies by manufacturer

Materials and Color

- Varies by manufacturer

Requirements

- Meet City dimensional requirements
- Adhere to ADA guidelines for accessible space provision, location, and dimensions

Sources

GreenBlue Urban
1-866-282-2743
4405 Anderson Road
Knoxville, TN 37918
United States
www.greenblue.com

Citygreen USA
515 S. Flower Street, 36th
Floor,
Los Angeles, CA 90071
Phone: (+1) 888 999-3990
Email: info@citygreen.com

Silva Cell/Deep Root
DeepRoot Green Infrastructure, LLC
101 Montgomery Street, Suite 2850
San Francisco, CA 94104
info@deeproot.com
Tel: 415 781 9700
Toll Free: 800 458 7668
www.deeproot.com



Soil cell system

Photo Credit: GreenBlue Urban

Streetscape Elements

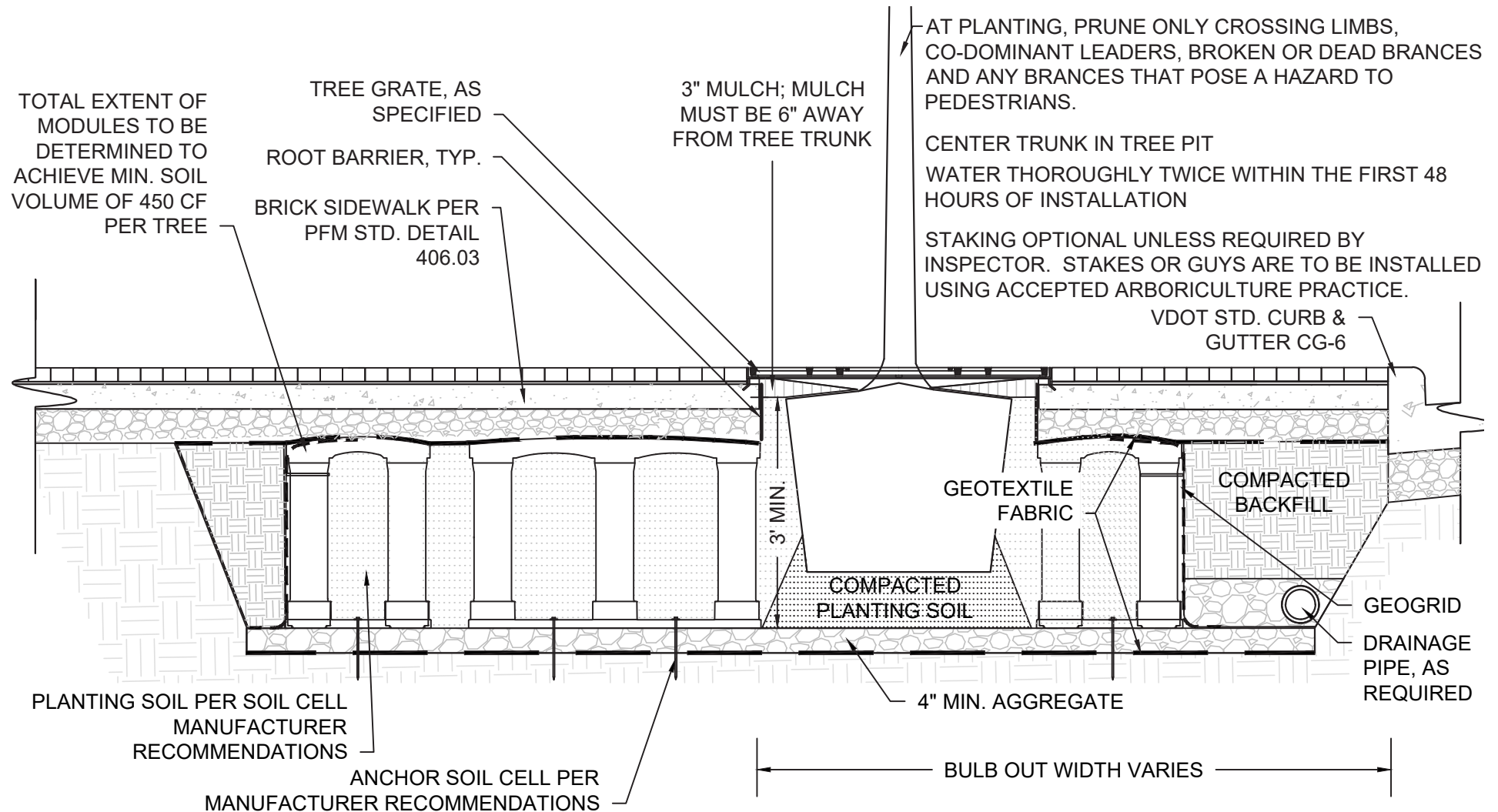

TREE PIT DETAIL - SOIL CELLS



L/KLA 12.11.18
REV. 1.24.19, 5.1.19

Streetscape Elements

TREE PIT - STRUCTURAL SOIL

Description

Structural soil was initially developed at Cornell University - CU-Structural Soil®. Formed from angular stone sized from 3/4 to 1-1/2 inches in size and soil, the product has load bearing capacity via the stone and soil volume to support tree growth. Placed under pavement, it provides a continuous and large volume of soil. CU soil is a patented product and can only be obtained from licensed facilities. It is not to be used in conjunction with stormwater infiltration.

Size

- CU-Structural Soil® has a proprietary specification that spells out stone size and shape, soil type, and mix

Materials and Color

- Angular stone and soil, (20 percent clay)

Requirements

- Meet CU-Soil® specifications or equal

Sources

CU-Soil® is a proprietary material patented by Cornell University and marketed under the trademarked names CU-Structural Soil® or CU-Soil®. By obtaining this material from an Amereq-licensed company, it assures that the material has been produced and tested to meet research-based specifications.

<http://www.amereq.com/>



Structural soil

Photo Credit: Amereq

Streetscape Elements

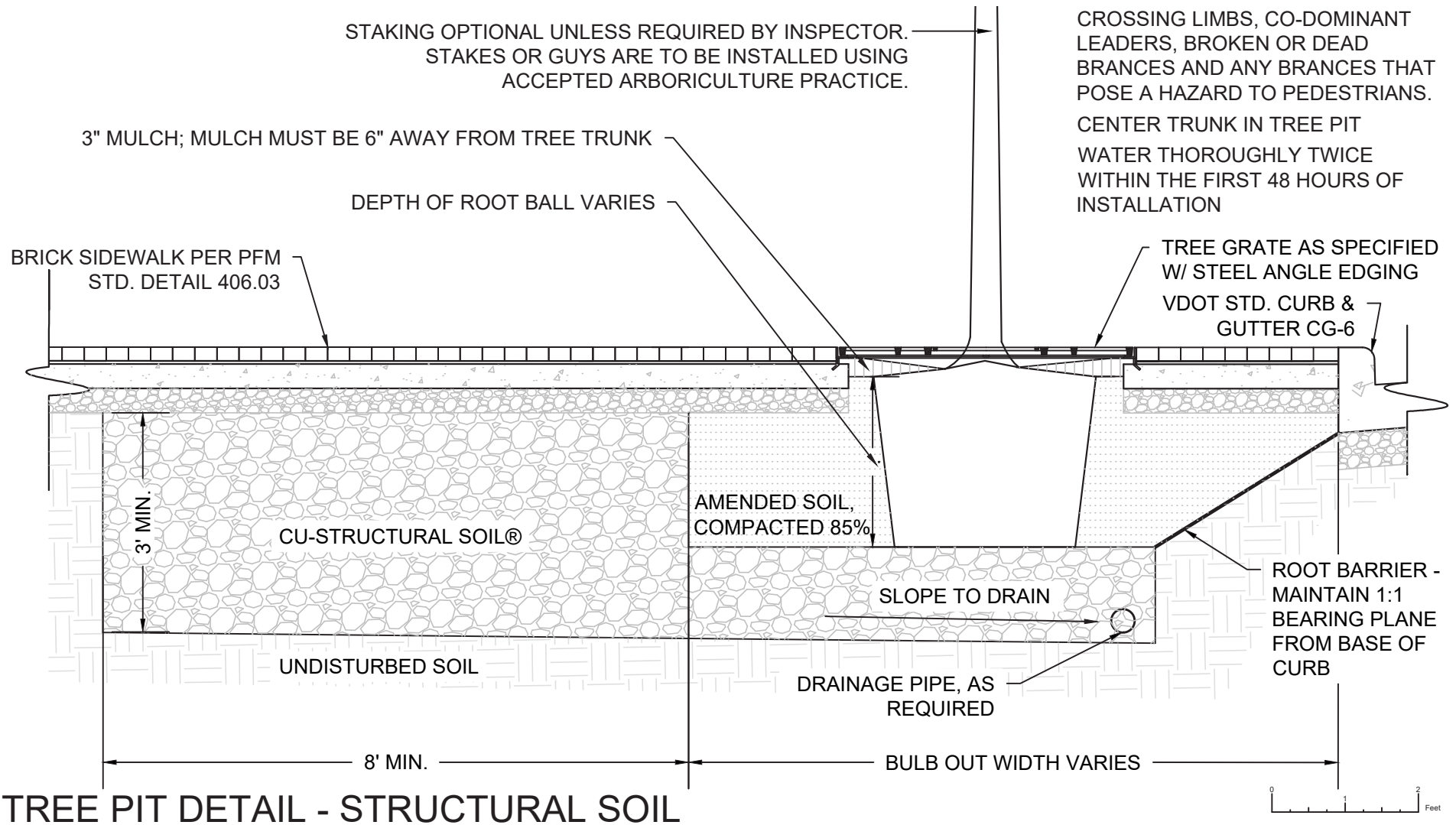

L/KLA 12.11.18
REV. 1.24.19, 4.8.19

Streetscape Elements

PLANT LIST FOR GROUNDCOVERS FOR USE IN TREE PITS, BULB OUTS, AND POTS

Liriope spicata

Rosa wichuiana

Hypericum calycinum

Cerastium tomentosum

Ajuga reptans

Galium odoratum

Asarum canadense

Lilyturf

Memorial Rose

St. John's Wort

Snow-in-Summer

Bugleweed

Sweet Woodruff

Wild Ginger



Ajuga reptans

Streetscape Elements

PLANT LIST FOR HANGING BASKET/HAYRACK BASKET

Spring

- Pansies
- Grape Hyacinth
- Snow Drops

Summer

- Roses (assorted)
- Petunias
- Grasses (variety of species such as Fountain Grass)
- Russian Sage
- Ice Plant
- Fuchsia
- Geranium
- Impatiens
- Ivy Geranium
- Lantana
- Lobelia
- Verbena Cascading
- Vinca Trailing
- Succulents

Fall

- Japanese anemone
- Sedum

Winter

- Erica
- Ornamental Kale
- Red Osier Dogwood branches
- Birch branches
- Evergreen cuttings
- Primrose
- Winter Jasmine
- Christmas fern (evergreen)



Photo Credit: Garden Artisans, LLC

Hayrack basket

Streetscape Elements

PLANT LIST FOR PLANTER POT

Spring

- Pansies
- Grape Hyacinth
- Snow Drops
- Crocus
- Daffodil/Narcissus varieties
- Dusty Miller
- Tulip
- Blue Sedge (ornamental native grass)

Summer

- Roses (assorted)
- Petunias
- Grasses (variety of species such as Fountain Grass)
- Russian Sage
- Ice Plant
- Fuchsia
- Geranium
- Impatiens
- Ivy Geranium
- Lantana
- Lobelia
- Verbena Cascading
- Vinca Trailing
- Aromatic Aster
- Calibrochoa (Million bells)
- Persian Shield
- Blue Mist (native)
- Black-eyed Susan (native)
- Threadleaf Blue Star (native, good through fall)
- Bacopa
- Purple coleus
- Sweet Potato Vine
- Succulents

Fall

- Japanese anemone
- Sedum
- Summer ongoing

Winter

- Erica
- Ornamental Kale
- Red Osier Dogwood branches
- Birch branches
- Evergreen cuttings
- Primrose
- Winter Jasmine
- Christmas fern (evergreen)

Choices are not limited to these recommendations, other selections may be made.



Pansies, Dusty Miller, ornamental ivy, and evergreen plantings

Streetscape Elements

PLANT LIST FOR SHRUBS FOR USE IN TREE PITS, BULB OUTS, AND POTS

Hamamelis virginiana

Witch Hazel

Ilex verticillata

Common Winterberry

Itea virginica

Virginia Sweetspire

Forsythia arnoldi

Arnold Dwarf Forsythia

Potentilla fruticosa

Bush Cinquefoil

Rhus aromatica

Fragrant Sumac

Spiraea japonica

Japanese Spiraea

Vaccinium angustifolium

Lowbush Blueberry

Jasminum nudiflorum

Winter Jasmine

Choices are not limited to these recommendations, other selections may be made.



Shrub planting with texture and color

Streetscape Elements

PLANTING GUIDANCE

Plant Selection

- Give preference to native, hardy, low maintenance plant materials
- Select salt tolerant plants, particularly if to be located within the Furnishings Zone
- Refer to the list of [Preferred Native Species for Urban Street Trees](#) in the *City of Fairfax Design Guidelines*

Soil Volume

- Ensure a minimum volume of 350 cf of planting medium for each street tree, with a maximum depth in calculating that volume of 3 feet
- If adequate soil volume is not available, use alternate techniques for street tree planting support such as soil cells, structural soil, suspended pavement, or linear pits connected under pavement; alternative techniques must be approved by City staff

Irrigation

- Where possible, fixed supplemental irrigation for pots and hanging baskets is desired - reservoirs or other alternative mechanisms

Location

- Provide clear distance for plant materials or pots from curb when located next to on-street parking (door swing)

Requirements

- Adhere to the City of Fairfax PFM's plant notes



Streetscape Elements

IDENTIFIERS

DIVISION MATRIX SHEET

- Gateway - Major
- Gateway - Minor
- Historic Markers
- Public Art Examples
 - Utility box wrap
- Wayfinding
 - Kiosks

Legend

-  Active Street Type 1
-  Active Street Type 2
-  Active Street Type 3

 HOD Streetscape Standard

 Other Standard

GATEWAY - MAJOR



GATEWAY - MINOR



HISTORIC MARKERS



PUBLIC ART EXAMPLES

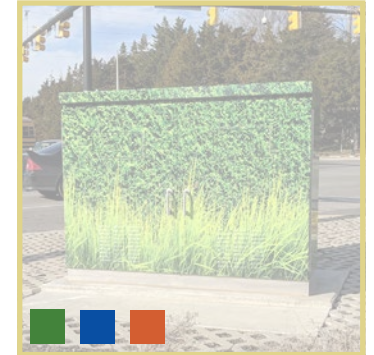

WAYFINDING FOR PARKING AND PEDESTRIANS



Streetscape Elements

GATEWAY - MAJOR

Description

Signifier of entry to the HOD and historic downtown Fairfax

Style

- Public art
- Landscape plantings
- Sign
- Lighting

Size

- Approximately 12 feet wide by 8 feet deep to provide adequate space for plantings, art, sign, and lighting

Materials and Color

- Breakaway posts for any signs

Location and Setbacks

- Northwest corner of intersection of West/North and Main Streets
- Southwest corner of East and Main Streets

Requirements

- Adhere to ADA guidelines for accessible space provision, location, and dimensions
- 2009 MUTCD Virginia Supplement Section 3B.19
- VDOT Standards and Details



Gateway Sign from 2008 Wayfinding Plan

Streetscape Elements

GATEWAY - MINOR

Description

Secondary entry identifier and welcome

Style

- City's current Old Town Fairfax Welcome sign

Size

- Match existing

Materials and Color

- Match existing
- Place in lawn or mulch bed

Location and Setbacks

- Locate within median where possible
- University Drive and North Street intersection
- Old Lee Highway and North Street intersection
- East Street and Sager Avenue intersection
- University Drive and edge of HOD boundary south of South Street
- Chain Bridge Road and Sager Avenue

Requirements

- Adhere to ADA guidelines for accessible space provision, location, and dimensions
- 2009 MUTCD Virginia Supplement Section 3B.19
- VDOT Standards and Details

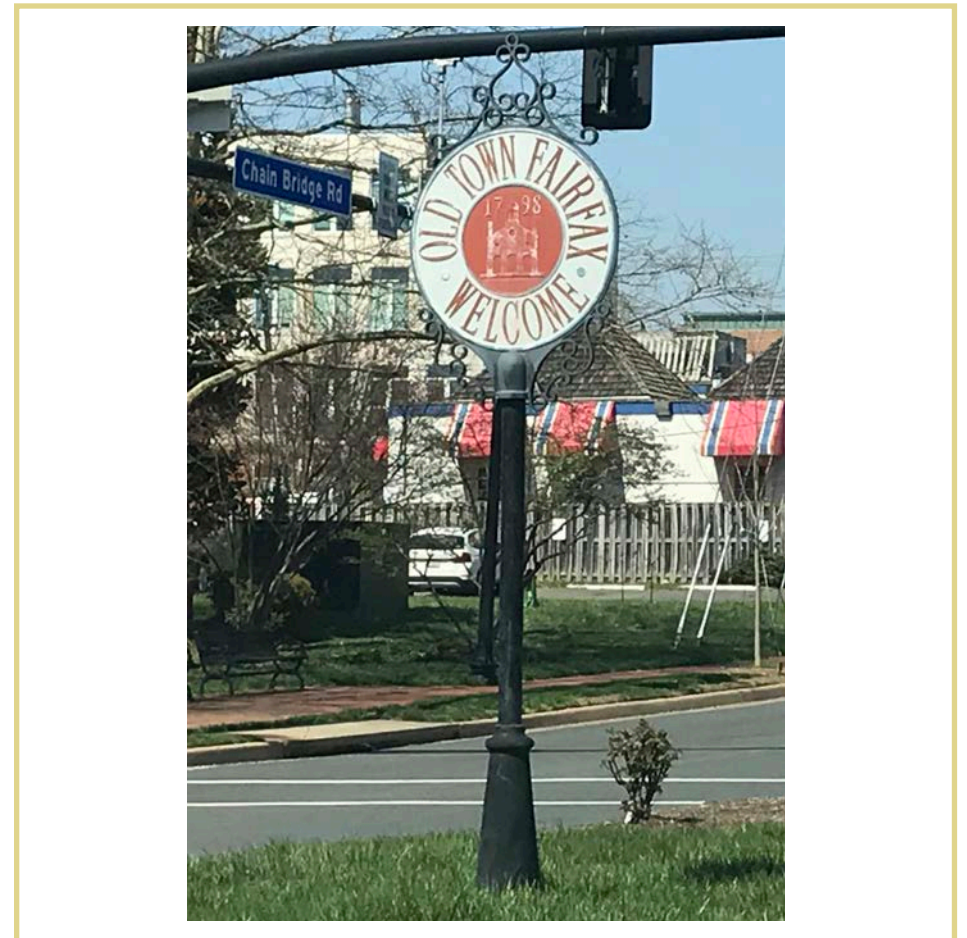

Minor Gateway Welcome sign

Streetscape Elements

HISTORIC MARKERS

Description

Interpretive and historic signs

Style

- Vary, from plaques to traditional Virginia signs (pictured) to interpretive panels or kiosks

Size

- Varies

Materials and Color

- Varies

Location and Setbacks

- Varies

Requirements

- Adhere to ADA guidelines for accessible space provision, location, and dimensions
- 2009 MUTCD Virginia Supplement Section 3B.19
- VDOT Standards and Details



Historic sign

Streetscape Elements

PUBLIC ART

Description

Public art enlivens, entertains and educates the observer

Style

- Varies

Size

- Varies

Materials and Color

- Varies

Location and Setbacks

- Varies

Requirements

- Selection criteria and process - City of Fairfax Commission on the Arts



*Utility wrap sponsored by the City of Alexandria's Public Art program
King Street/Braddock Road/Quaker Lane traffic island*

Streetscape Elements

WAYFINDING FOR PARKING AND PEDESTRIANS

Description

Ten years ago, a comprehensive custom wayfinding sign plan for the downtown area of the City of Fairfax was prepared by Frazier Associates. The design process at that time explored options and the final design was selected by the City with the help of citizens. The Planning Department managed the project. Since that time, some of the system has been implemented.

Parking directional signs, while located on the custom wayfinding, is also located on other directional signage throughout the downtown. One of the key goals of wayfinding is to direct visitors to key destinations and more visitor information. Consistent signage is not in place to support visitors getting to key destinations in the downtown, to find parking and then to find their way to downtown destinations on foot.

Style

- A range of appropriate pedestrian and parking oriented wayfinding signs are included in the Streetscape Standards

Size

- Varies with sign, as illustrated on the following pages

Materials and Color

- Varies with sign, as illustrated on the following pages although color and materials continue the sign and wayfinding vocabulary established in the 2008 wayfinding sign plan; final colors of symbols to be determined by City staff

Location and Setbacks

- Varies, all sign placements must adhere to the City's regulations and setback criteria
- HOD and TOD

Requirements

- Adhere to ADA guidelines for accessible space provision, location, and dimensions

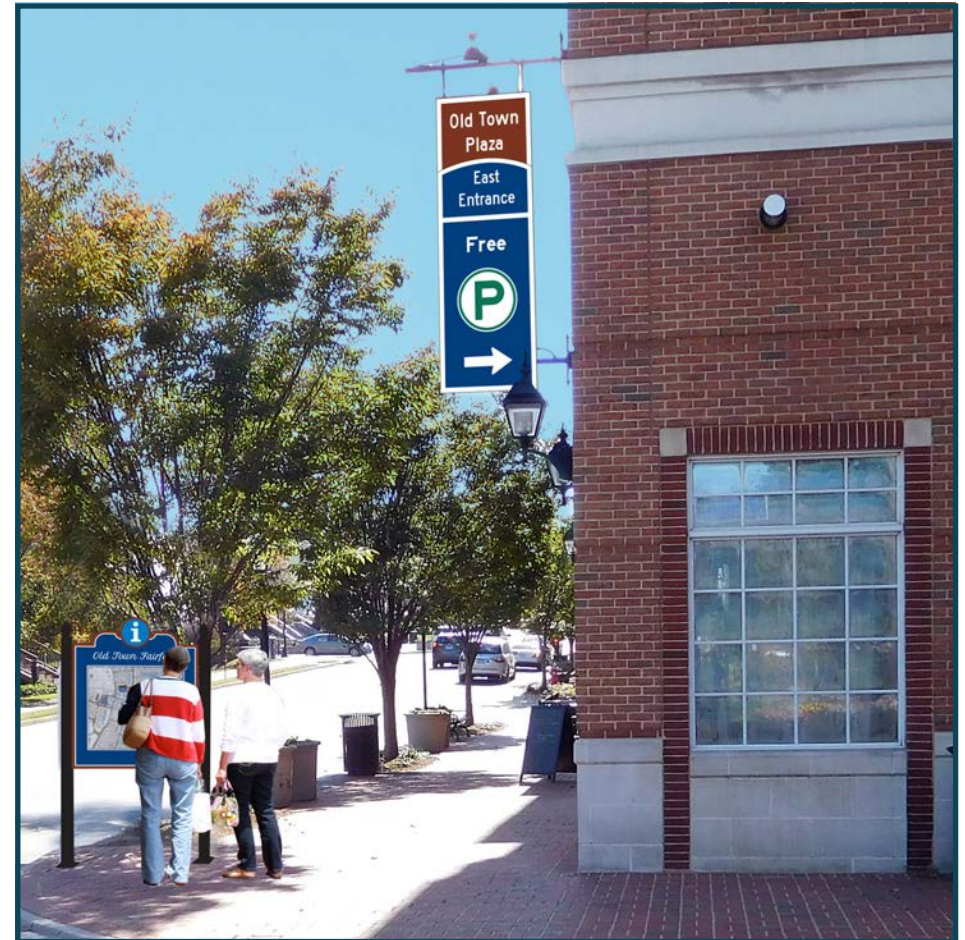

Proposed wayfinding sign for parking garage

Streetscape Elements

HOD PARKING DESIGN IDENTIFICATION SIGNS AND PEDESTRIAN WAYFINDING

Design

The design addresses the issue of visibility and readability of the parking signs to enhance motorists ability to find parking.

- **Parking Directional/Identification Signs:** This design uses the current custom wayfinding system, but reverses the colors so that the dark blue is the background color of the sign while the rust/brown is the accent color at the top. Changing the background color to blue helps provide more contrast and “pop” of the signs color against the brick buildings in the downtown landscape. The size of the parking icon is increased and “free” is removed making it more eye-catching and easier to read. The post and panel parking identification sign has the parking icon breaking the top of the sign panel to enhance maximum attention.
- The ‘P’, although shown in green, can be changed to blue per City staff recommendation.
- **Pedestrian Information Kiosk:** The existing white “Free Public Parking” kiosk signs that use blue type and maps on low post and panel sign type are more conducive to pedestrian information kiosks as motorist are not conditioned to look for parking directional information on kiosks. Typically, once a motorist has parked their car and gotten out they need help getting oriented and directed to walkable destinations. In this design, the existing parking kiosk is refurbished into the pedestrian information kiosk because the location of the existing parking kiosk signs are in perfect locations for pedestrian access to information. The parking information can remain on the sign. The design of the kiosk uses the same colors used in parking directional/identification signs above.

Location Recommendation

Parking identification/regulatory signs oriented parallel to the roadway should be reoriented perpendicular to the roadway and increased in size to a scale that motorist can easily read.

- General landscaping maintenance is required for optimal visibility of the parking signs and the projecting parking identification signs.

Programming

The content for the parking directional signs requires updates to provide a clear and cohesive system. Some existing conditions and proposed changes include the following.

- Some current parking directional signs, particularly on University Drive going north from North St, cause confusion as to where to turn to get to the parking decks. For instance to the left after the wayfinding street sign is a large vehicular opening into the Old Town Plaza that is actually a service entrance. The left turn to access public parking is further down at the end of the building, but the building sign is hidden by trees and the entrance is recessed and not visible to the motorist. The street sign needs to be redesigned and building signage upgraded.
- The library parking deck does not have clear identification or regulatory information regarding public parking. The directional sign should say, for instance, “Library Parking,” not “Free Public Parking” at this location given the limited general public parking times allowed.
- New parking identification signs should replace existing parking identification kiosk signs at all public parking surface lots/garages.

Streetscape Elements

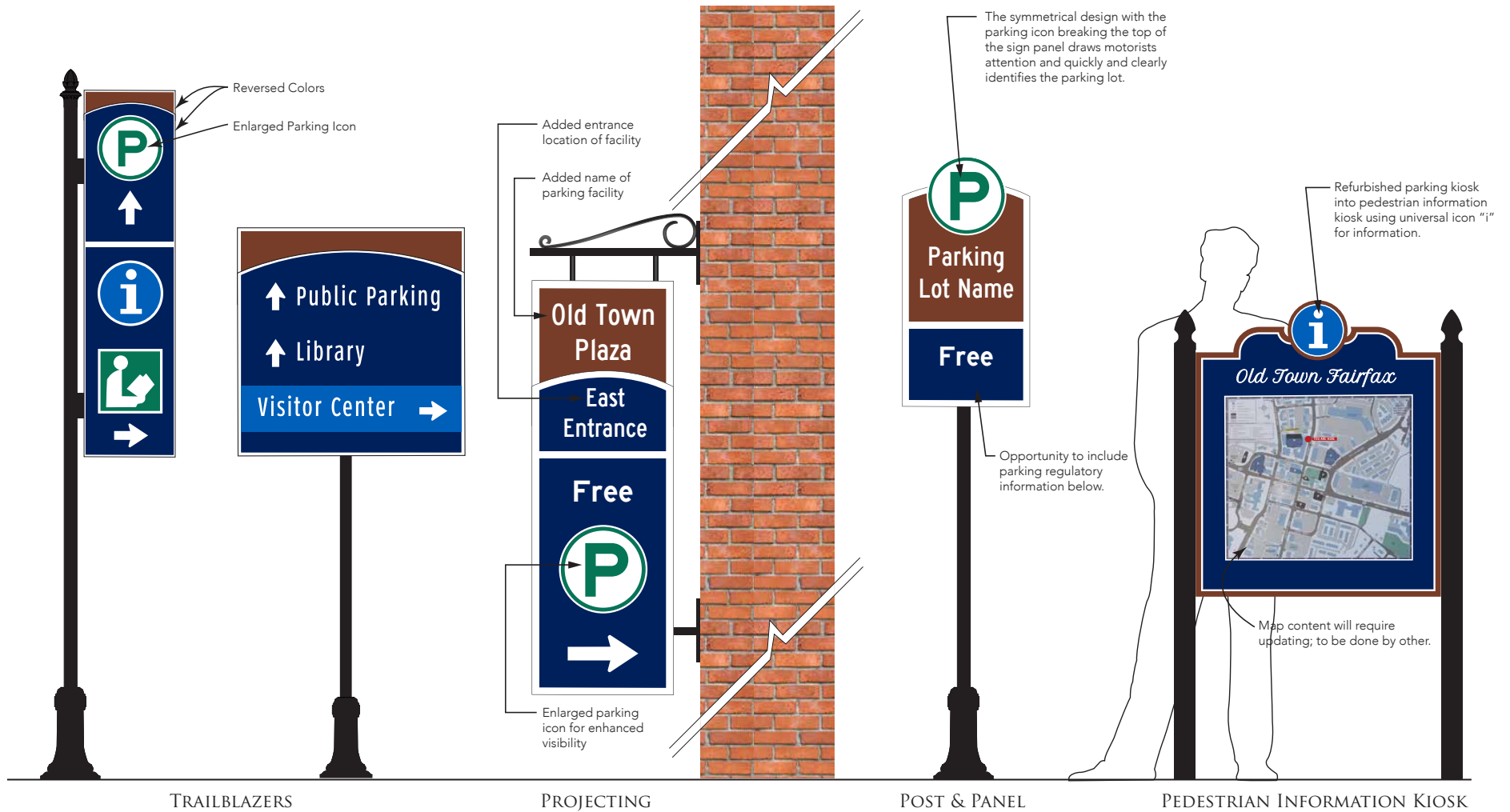

WAYFINDING SIGNS FOR PEDESTRIAN AND PARKING IDENTIFICATION

Note: The "P", shown in green, can be modified and produced in blue per City staff direction.

Streetscape Elements



Existing conditions and signs

Streetscape Elements



Illustration of proposed pedestrian information kiosk and projected parking sign



APPENDIX

Appendix

ABBREVIATIONS AND ACRONYMS

AASHTO	American Association of State Highway and Transportation Officials
ADA	Americans with Disabilities Act
ADAAG	ADA Accessibility Guidelines
ANSI	American National Standards Institute
HOD	Historic Overlay District
IESNA	Illuminating Engineering Society
LF	Linear Feet
MUTCD	Manual on Uniform Traffic Control Devices
NRHP	National Register of Historic Places
OD	Outside Diameter
PFM	City of Fairfax Public Facilities Manual
PROWAG	Public Rights-of-Way - United States Access Board
TOD	Transition Overlay District
VDOT	Virginia Department of Transportation
VLR	Virginia Landmarks Register
ZO	City of Fairfax Zoning Ordinance

REFERENCES AND DEFINITIONS

City of Fairfax Public Facilities Manual

www.fairfaxva.gov/government/public-works/public-facilities-manual

The Public Facilities Manual for the City of Fairfax is available online in portable document format (PDF). This manual was prepared to facilitate ease of use by both the design engineers and the contractors. The various elements that comprise this manual have been compiled from adopted policies and procedures, both current and new standard details, specifications, and practices. This manual contains the information needed by design engineers, developers, and contractors to facilitate design, development, and construction within the City of Fairfax service area.

City of Fairfax's Design Guidelines

www.fairfaxva.gov/government/community-development-planning/community-development

The Design Guidelines publication is an official policy document that expands upon the concepts of the design principles set forth in the Comprehensive Plan as mentioned above. While the guidelines provide specific recommendations for development, they cannot, and are not intended to, cover all circumstances.

Rather, the structure and content of the manual are meant to give owners, developers, designers and reviewers the perspective to address the unique conditions of each project and the flexibility to develop designs that meet the intent, principles and spirit of the guidelines.

The intent of the guidelines is to guide design decisions within the districts, not dictate them. These are a set of principles, not a set of strictly followed laws. City staff, the Board of Architectural Review and City Council should follow the intent of the guidelines but interpret them generally and not substitute them for common sense and good judgment.

IESNA American Standard Practice for Roadway Lighting (RP-8-14)

<https://www.ies.org/product/roadway-lighting/>

The primary purpose of this Standard Practice is to serve as the basis for design of fixed lighting for roadways, streets, adjacent bikeways, and pedestrian ways. The Standard Practice deals entirely with lighting design and does not give

Appendix

advice on construction. Its primary purpose is to provide recommended practices for designing new continuous lighting systems for roadways and streets. It is not intended to be applied to existing lighting systems until such systems are completely redesigned. It has been prepared to advance the art, science, and practice of roadway and street lighting in North America. Roadway and street lighting includes pedestrian and bikeway lighting when it is associated with the public right-of-way.

This document has been discontinued and its content is now included in RP-8-18.

Virginia Department of Transportation (VDOT) Road and Bridge Standards

http://www.virginiadot.org/business/locdes/2016_road_and_bridge_standards.asp

Construction details and standards for improvements within the VDOT right-of-way, including standard curb details.

Virginia Department of Transportation (VDOT) Road Design Manual

<http://www.virginiadot.org/business/locdes/rdmanual-index.asp>

Appendices include geometric design standards for various street types, clear zone/offset guidelines, and intersection and interchange design guidelines.