

Ladder Truck FFX

	feet
Width	: 10.42
Track	: 8.50
Lock to Lock Time	: 6.0
Steering Angle	: 33.3

N.T.S.

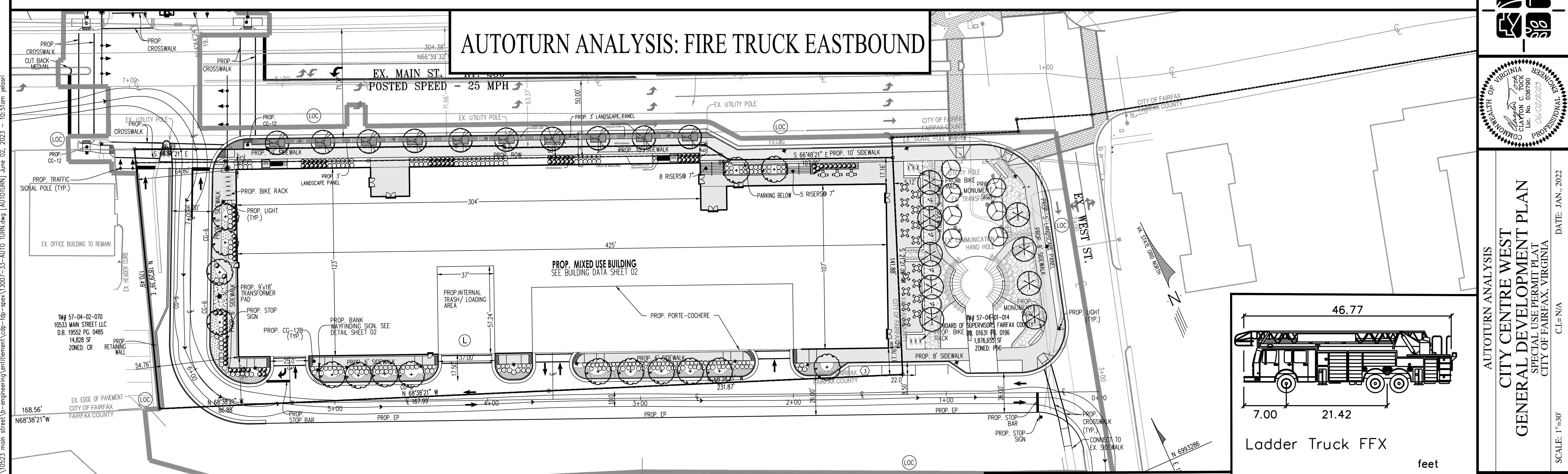

Ladder Truck FFX

	feet
Width	: 10.42
Track	: 8.50
Lock to Lock Time	: 6.0
Steering Angle	: 33.3

N.T.S.

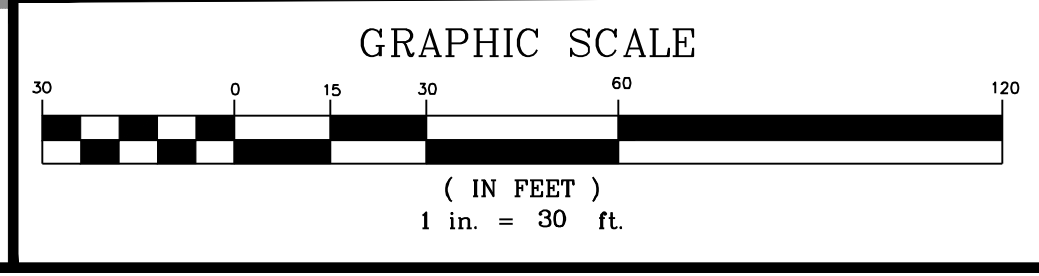

PLANDATE 01-18-22 04-20-22 06-02-23	No. DATE DESCRIPTION REVISIONS
<p style="font-size: small;">Urban, Ltd. 4000 TECHNOLOGY CT. CHANTILLY, VA. 20151 TEL. 703.642.2306 FAX 703.642.1888 www.urban-lltd.com</p>	
<p style="font-size: x-small;">Professional Engineer Clayton C. Brock Lic. No. 008790 06/02/2023</p>	
AUTOTURN ANALYSIS <b>CITY CENTRE WEST</b> GENERAL DEVELOPMENT PLAN SPECIAL USE PERMIT PLAN CITY OF FAIRFAX, VIRGINIA	
SCALE: 1"=30' DATE: JAN., 2022 C.I.= N/A	
SHEET 23 OF 51 FILE No. RZ-13007	

Urban, Ltd. - J:\085\10523 main street\engineering\mittinen\cap-dp-spec\13007-33-AUTO TURN.dwg [AUTOTURN] June 02, 2023 - 10:51am, yellow

# AUTOTURN ANALYSIS: BANK

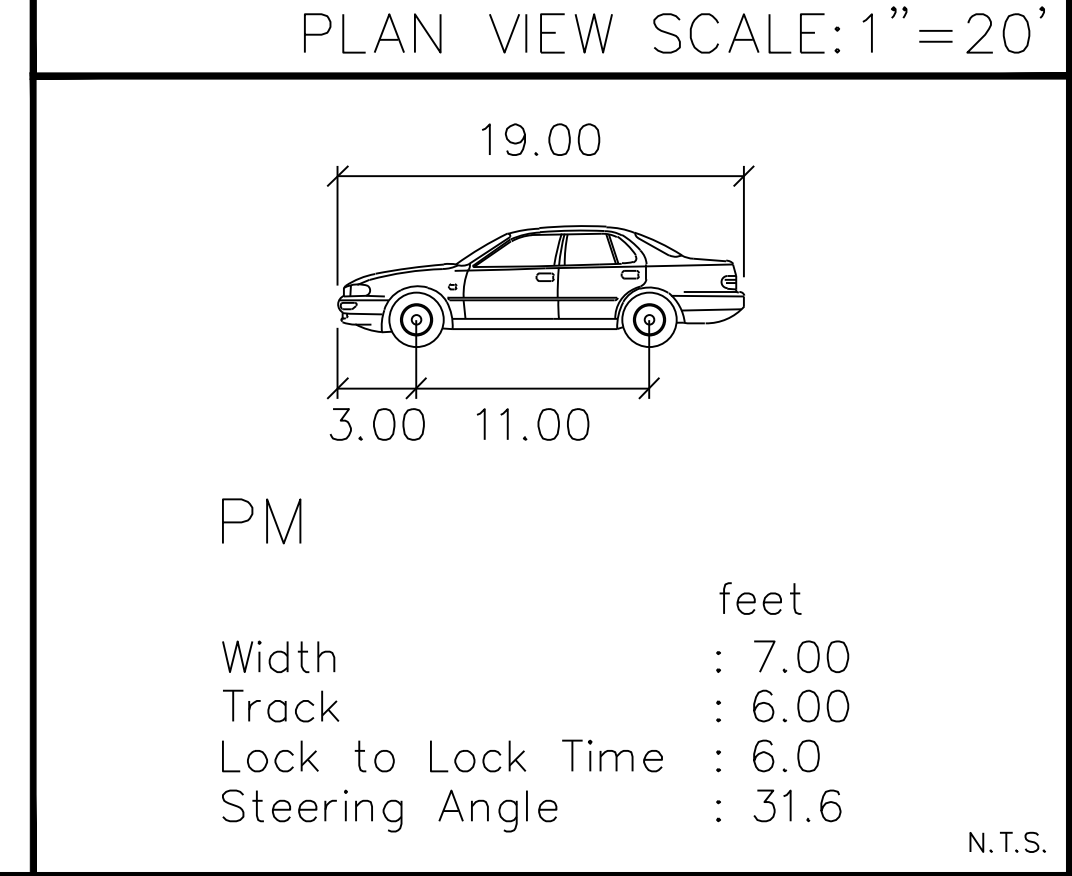
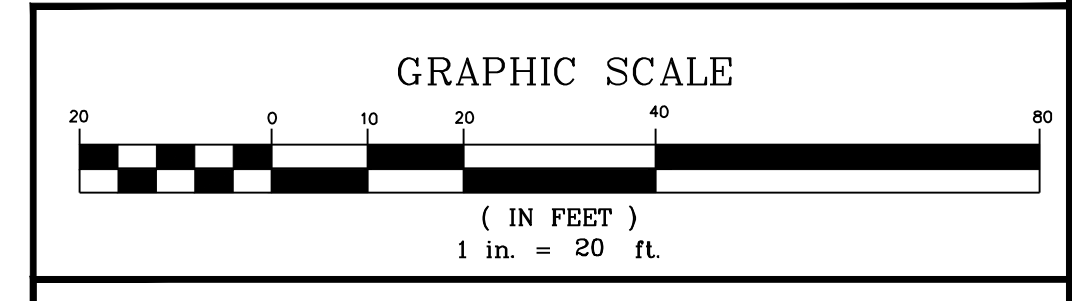
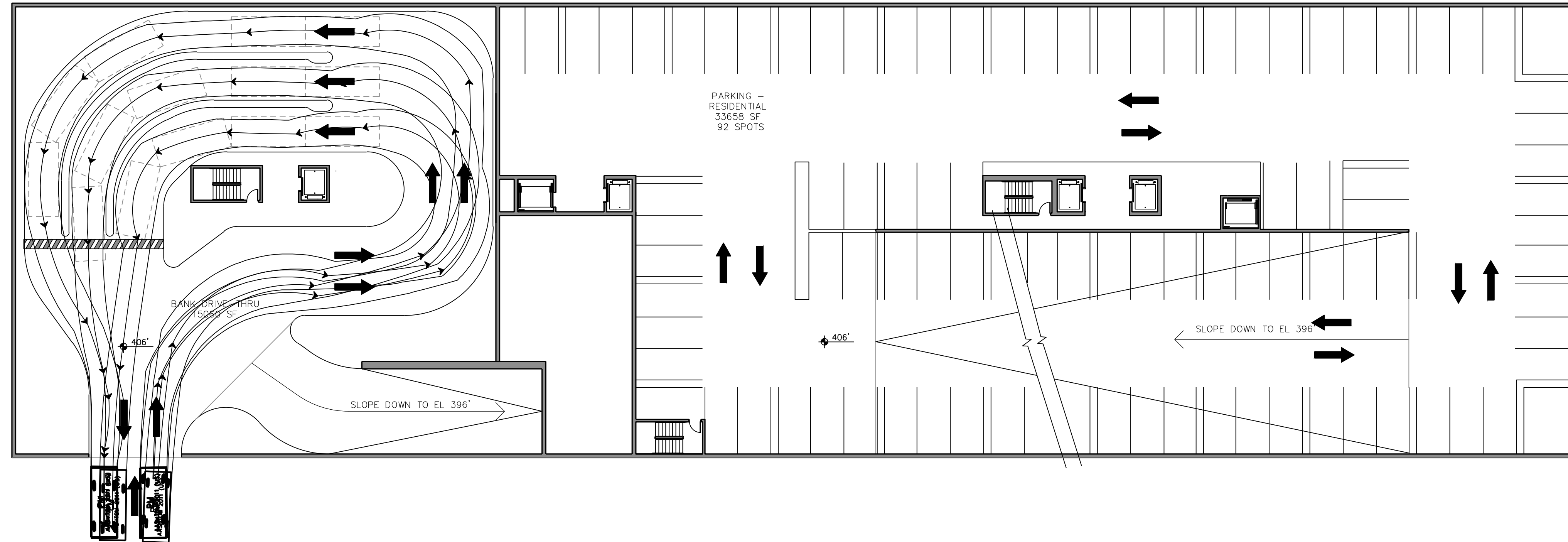

Urban, Ltd. - J:\0851\0523 main street\p-engineering\autoturn\autoturn.dwg [AUTOTURN (2)] June 02, 2023 - 10:51am yelbar

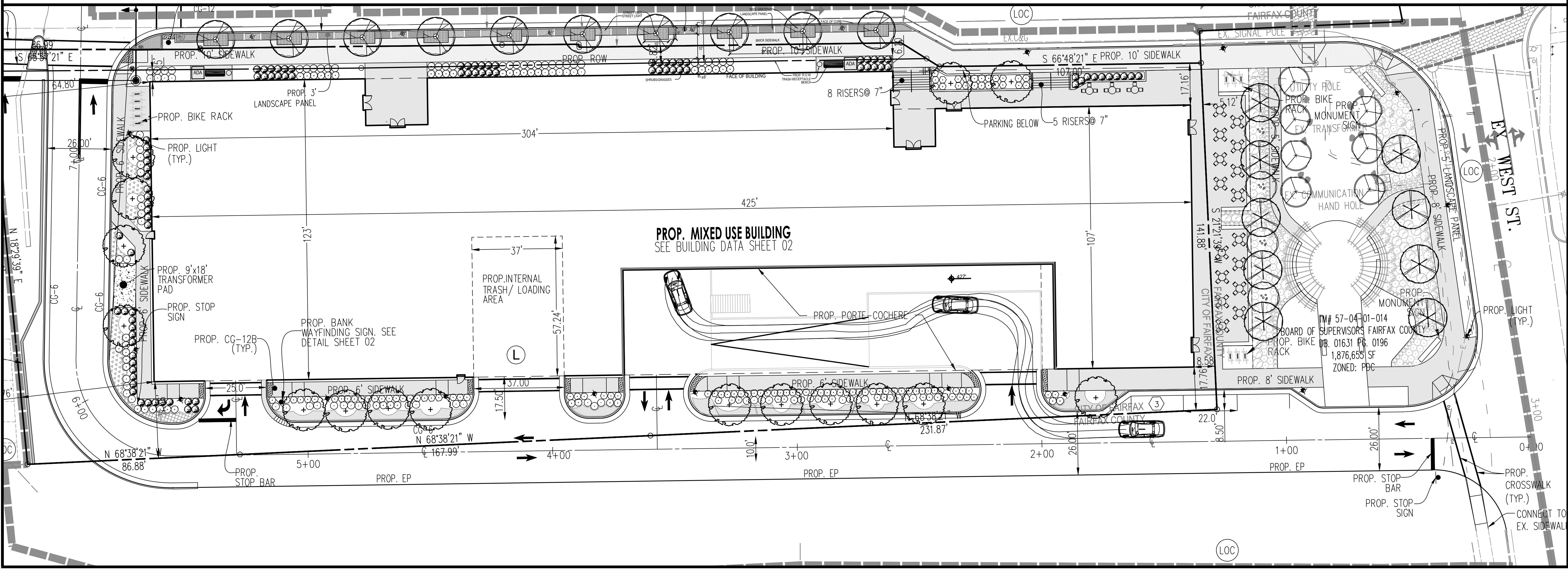

PLN DATE	01-18-22	DESCRIPTION
	04-20-23	
	06-02-23	
No.	DATE	REVISIONS
Urban, Ltd. 4000 TECHNOLOGY CT. CHANTILLY, VA. 20151 TEL. 703.642.2306 FAX 703.642.2308 www.urban-lltd.com		
PLANNERS/ENGINEERS/LANDSCAPE ARCHITECTS/LEAD SERVICES		
AUTOTURN ANALYSIS CITY CENTRE WEST GENERAL DEVELOPMENT PLAN SPECIAL USE PERMIT PLAT CITY OF FAIRFAX, VIRGINIA		
SCALE: AS NOTED	DATE: JAN., 2022	
SHEET 24 OF 51	FILE No. RZ-13007	

### AUTOTURN ANALYSIS: COMMERCIAL TRUCK EASTBOUND

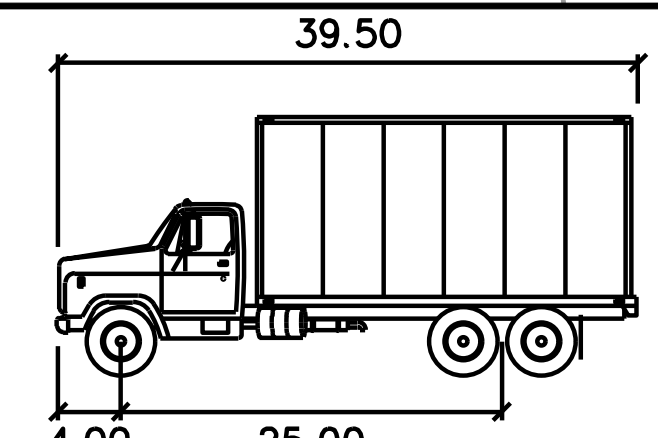
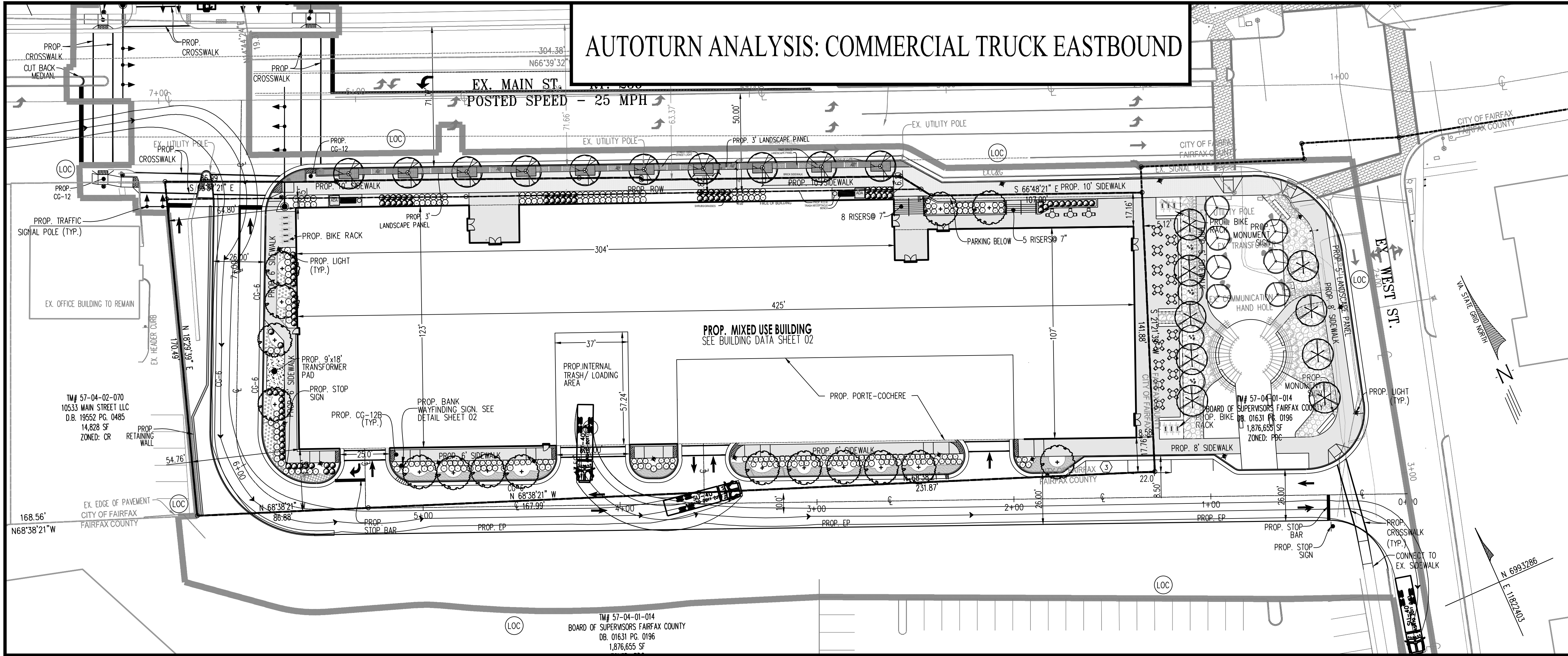

**SU-40**

Width	: 8.00
Track	: 8.00
Lock to Lock Time	: 6.0
Steering Angle	: 31.8

feet

### AUTOTURN ANALYSIS: COMMERCIAL TRUCK WESTBOUND

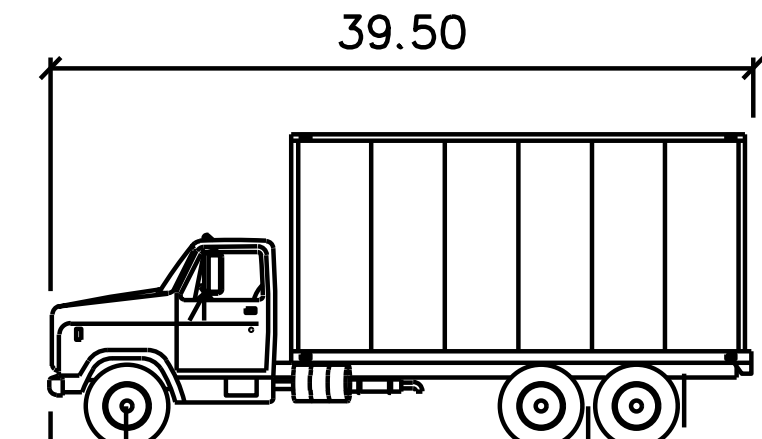
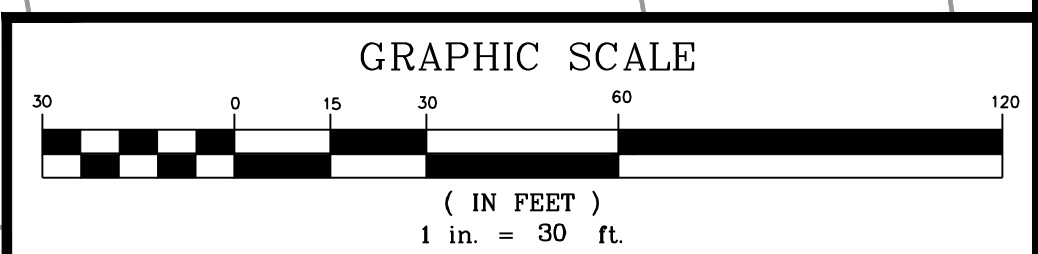
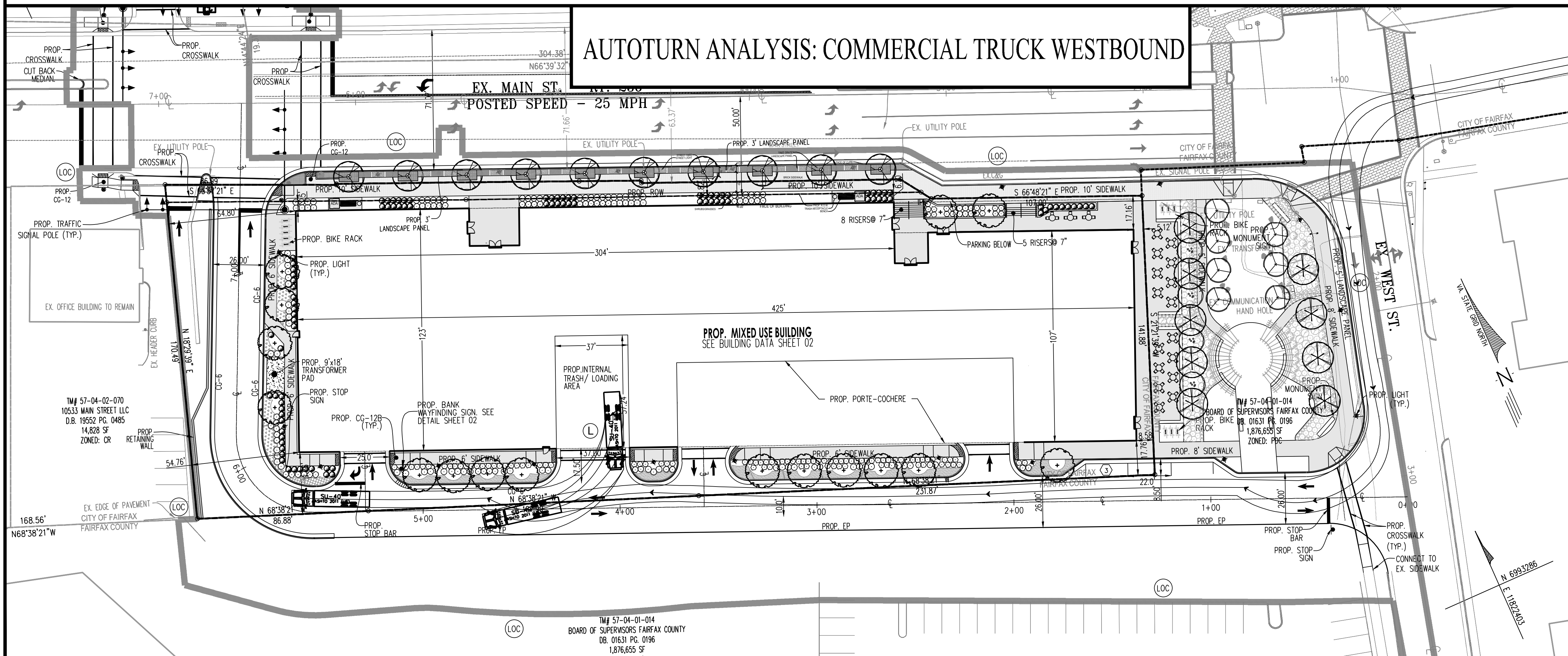

**SU-40**

Width	: 8.00
Track	: 8.00
Lock to Lock Time	: 6.0
Steering Angle	: 31.8

feet

NO.	DATE	REVISIONS	DESCRIPTION

PLAN DATE  
 01-18-22  
 04-20-22  
 06-02-23

Urban, Ltd.  
 4000 TECHNOLOGY CT.  
 CHANTILLY, VA. 20151  
 TEL. 703.642.2306  
 FAX 703.642.2888  
 www.urban-lltd.com

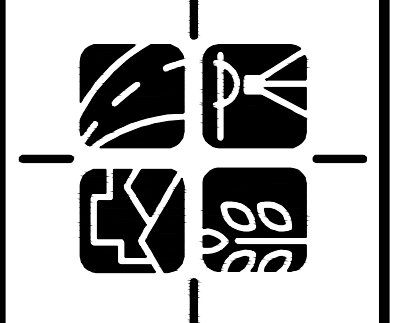
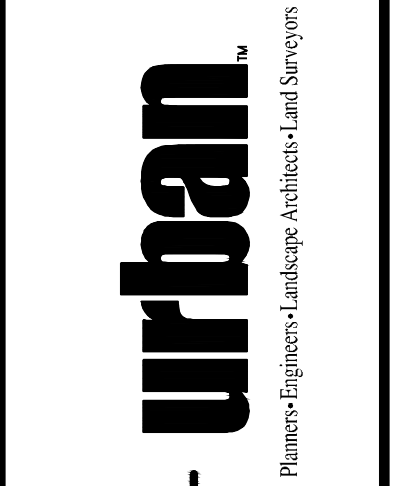

**AUTOTURN ANALYSIS**  
**CITY CENTRE WEST**  
**GENERAL DEVELOPMENT PLAN**  
**SPECIAL USE PERMIT PLAN**  
**CITY OF FAIRFAX, VIRGINIA**

SCALE: 1" = 30'  
 CI. = N/A

DATE: JAN., 2022

SHEET  
 25  
 OF  
 51

FILE No.  
 RZ-13007

N.T.S.

Urban, Ltd. - J:\085\10523 main street\p-engineering\mittent\cap-dpr-spec\13007-33-PED-CIRC.dwg [PED-CIRC] June 02, 2023 - 10:52am veldar

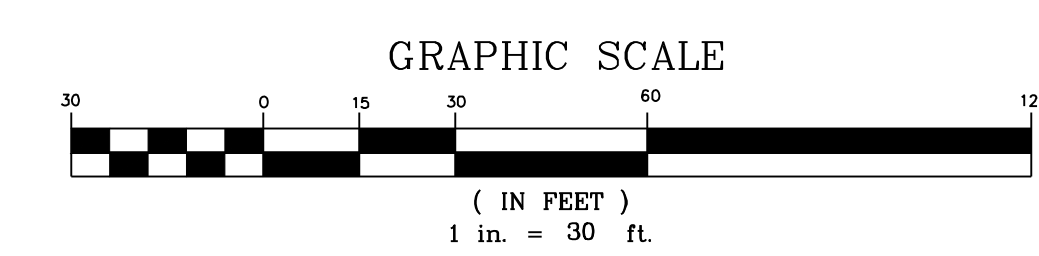
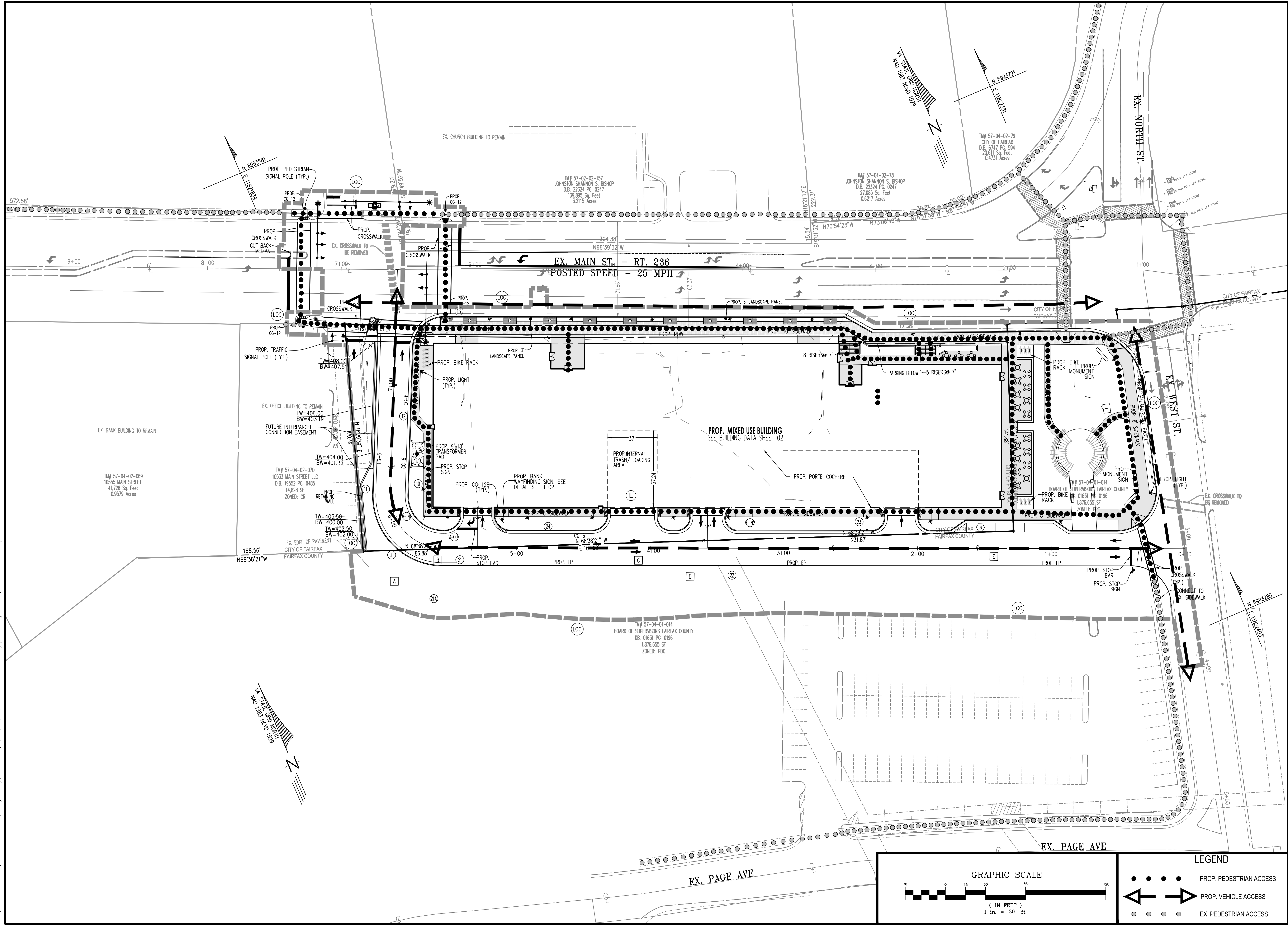

LEGEND	
	PROP. PEDESTRIAN ACCESS
	PROP. VEHICLE ACCESS
	EX. PEDESTRIAN ACCESS

<p><b>SITE CIRCULATION</b></p> <p><b>CITY CENTRE WEST</b></p> <p><b>GENERAL DEVELOPMENT PLAN</b></p> <p>SPECIAL USE PERMIT PLAT</p> <p>CITY OF FAIRFAX, VIRGINIA</p> <p>DATE: JAN., 2022</p> <p>SCALE: 1"=30'</p> <p>C.I.= N/A</p>	<table border="1" style="width: 100%; border-collapse: collapse;"> <tr> <th>PLN DATE</th> <th>NO.</th> <th>DATE</th> <th>DESCRIPTION</th> </tr> <tr> <td>01-18-22</td> <td>1</td> <td>01-18-22</td> <td>ISSUED FOR PERMIT</td> </tr> <tr> <td>04-20-23</td> <td>2</td> <td>04-20-23</td> <td>REVISED</td> </tr> <tr> <td>06-02-23</td> <td>3</td> <td>06-02-23</td> <td>REVISED</td> </tr> </table> <div style="text-align: center;"> <p>urban Planners/Engineers/Landscape Architects/Land Services</p> </div> <div style="text-align: center;"> </div> <p>Urban, Ltd. 4000 D TECHNOLOGY CT. CHANTILLY, VA. 20151 TEL. 703.642.2306 FAX 703.642.2308 www.urban-lltd.com</p>	PLN DATE	NO.	DATE	DESCRIPTION	01-18-22	1	01-18-22	ISSUED FOR PERMIT	04-20-23	2	04-20-23	REVISED	06-02-23	3	06-02-23	REVISED
PLN DATE	NO.	DATE	DESCRIPTION														
01-18-22	1	01-18-22	ISSUED FOR PERMIT														
04-20-23	2	04-20-23	REVISED														
06-02-23	3	06-02-23	REVISED														

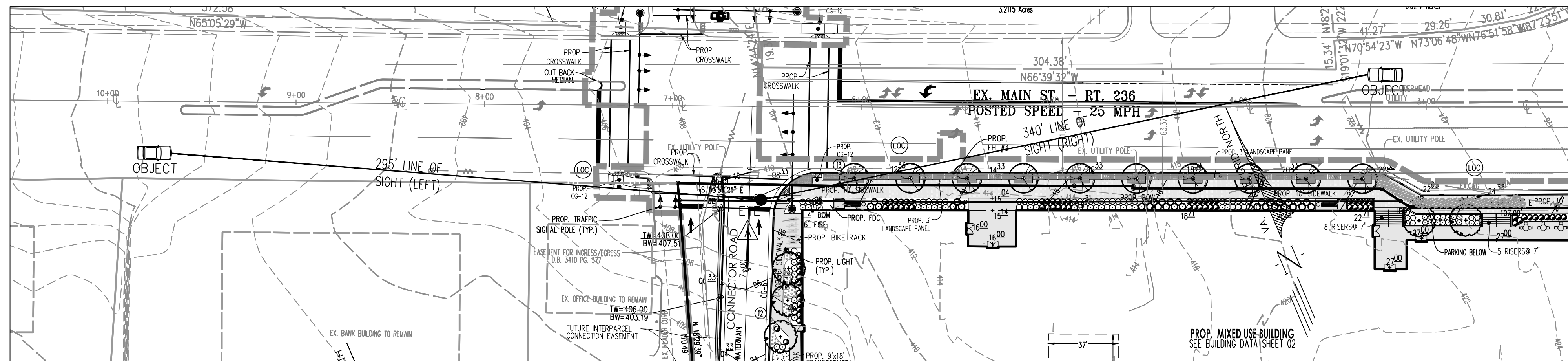

SIGHT DISTANCE PROFILE  
 MAIN ENTRANCE ON MAIN ST.  
 EYE "A"  
 POSTED SPEED = 25 MPH  
 PROFILE SCALE: H:1"=50'; V:1"=5'

PLAN VIEW  
 SCALE: 1"=40'

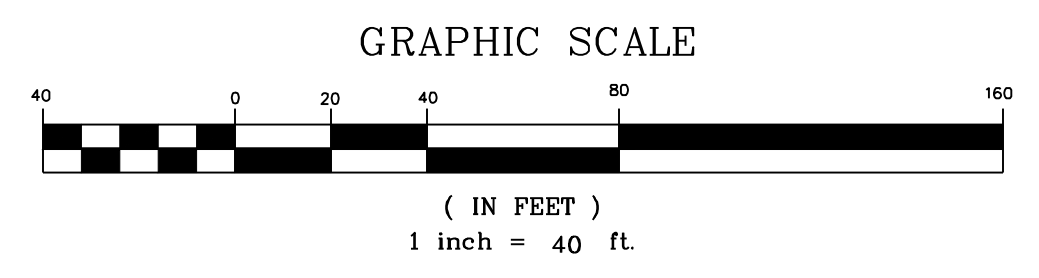
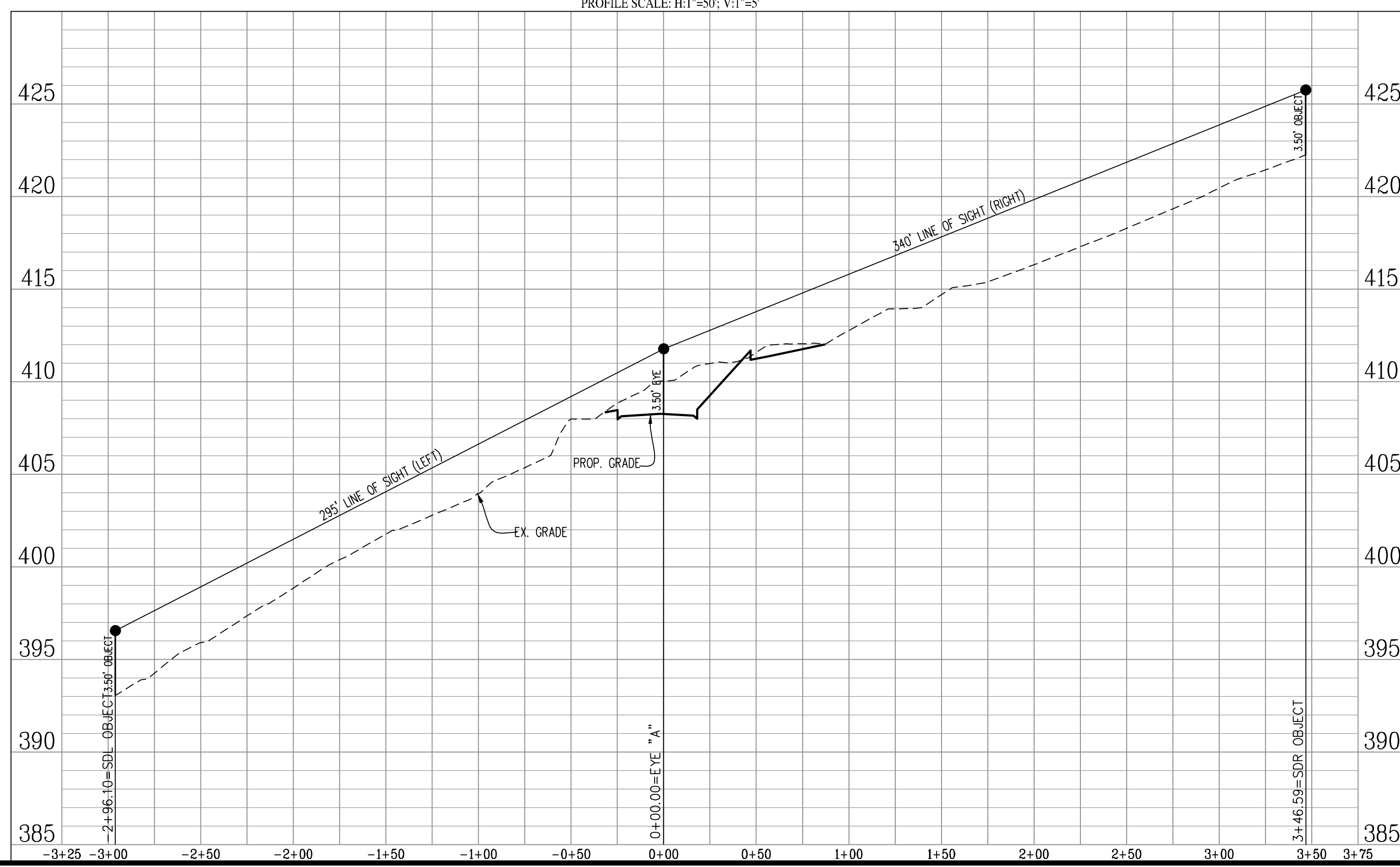

NOTE: TREES AND LANDSCAPING WITHIN THE SIGHT DISTANCE TRIANGLE WILL BE PRUNED AND LIMBED UP TO 6' TO MAINTAIN ADEQUATE SIGHT DISTANCE.

Urban, Ltd. - J:\085\0523 main street\engineering\entitlement\cdp-fdr-spec\13007-31-SIGHT.Dwg [SIGHT] June 02, 2023 - 10:52am yelazi

Urban, Ltd. 4000 TECHNOLOGY CT. CHANTILLY, VA. 20151 TEL: 703.642.2306 FAX: 703.642.2308 www.urban-llc.com	
<b>SIGHT DISTANCE PROFILES</b> <b>CITY CENTRE WEST</b> <b>GENERAL DEVELOPMENT PLAN</b> SPECIAL USE PERMIT PLAN CITY OF FAIRFAX, VIRGINIA	
SHEET 27 OF 51  FILE No. RZ-12907	DATE: JAN., 2022  SCALE: AS NOTED C.I.= 2'
PLAN DATE 01-18-22 04-20-22 06-02-23	REVISIONS No. DATE DESCRIPTION

Urban, Ltd. - J:\085\0523 main street\engineering\entitlement\cdp-fdr-spec\13007-31-SIGHT.Dwg [SIGHT.D] June 02, 2023 - 10:52am veldesi

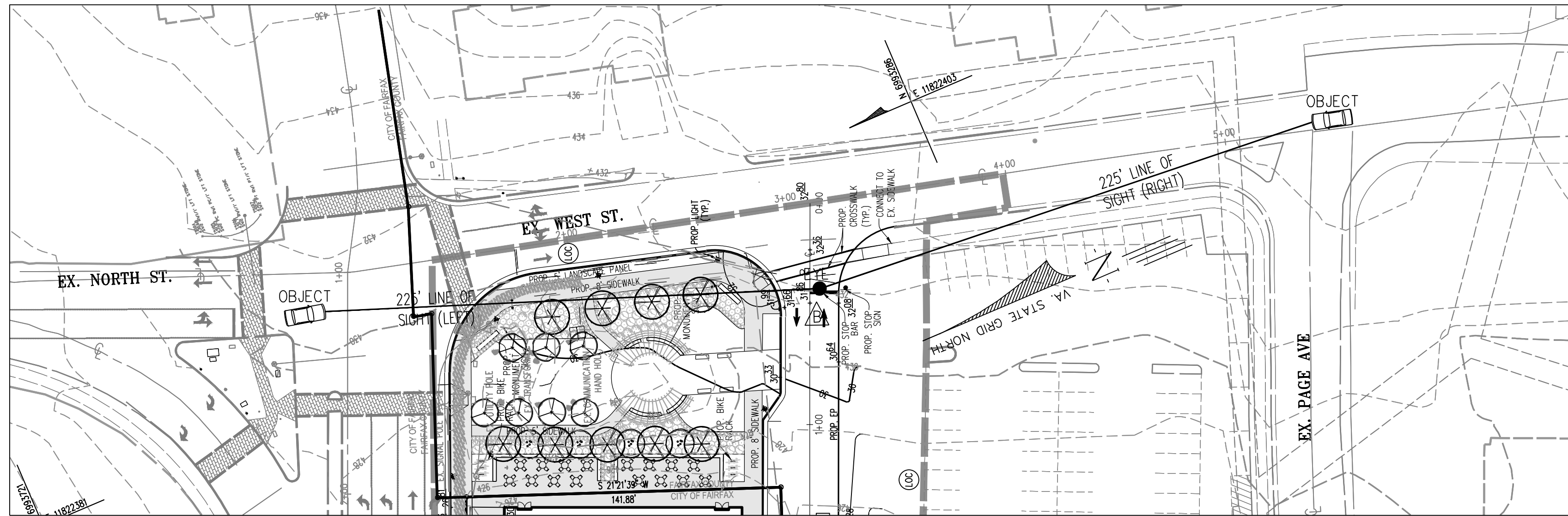

**SIGHT DISTANCE PROFILE**  
**MAIN ENTRANCE ON WEST ST.**  
 EYE "B"  
 POSTED SPEED = 10 MPH  
 PROFILE SCALE: H:1"=50'; V:1"=5'

**PLAN VIEW**  
 SCALE: 1"=40'

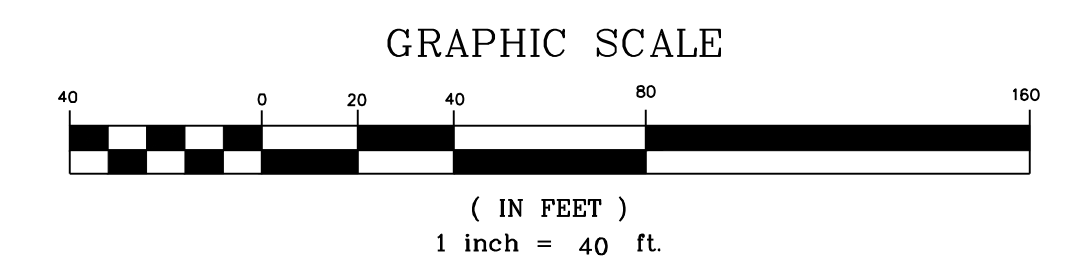
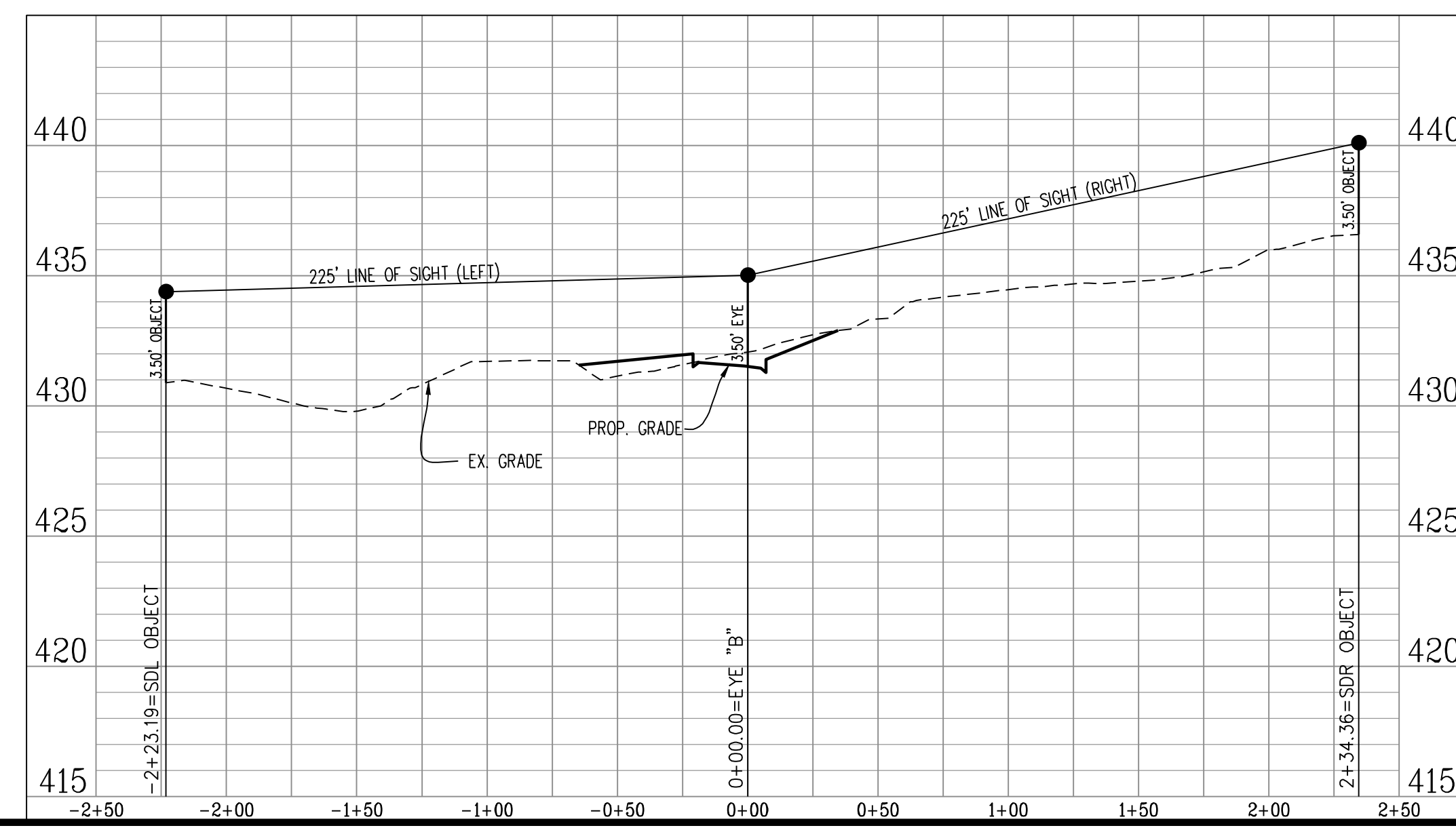

NOTE: TREES AND LANDSCAPING WITHIN THE SIGHT DISTANCE TRIANGLE WILL BE PRUNED AND LIMBED UP TO 6' TO MAINTAIN ADEQUATE SIGHT DISTANCE.

<p><b>SIGHT DISTANCE PROFILES</b>  <b>CITY CENTRE WEST</b>  <b>GENERAL DEVELOPMENT PLAN</b>                  SPECIAL USE PERMIT PLAT                  CITY OF FAIRFAX, VIRGINIA</p>	<p>DATE: JAN., 2022                  SCALE: AS NOTED                  C.I.= 2'</p>																														
<p>SHEET 28 OF 51</p> <p>FILE No. RZ-12907</p>	<p>Urban, Ltd.                  4000 TECHNOLOGY CT.                  CHANTILLY, VA. 20151                  TEL. 703.642.2306                  FAX 703.678.7888                  www.urban-llc.com</p> <p style="text-align: center;"><b>urban</b>                  Planners • Engineers • Landscape Architects • Land Surveyors</p>																														
	<table border="1" style="width: 100%; border-collapse: collapse;"> <thead> <tr> <th style="width: 10%;">No.</th> <th style="width: 10%;">DATE</th> <th style="width: 80%;">DESCRIPTION</th> </tr> </thead> <tbody> <tr> <td> </td> <td> </td> <td> </td> </tr> <tr> <td> </td> <td> </td> <td> </td> </tr> <tr> <td> </td> <td> </td> <td> </td> </tr> <tr> <td> </td> <td> </td> <td> </td> </tr> <tr> <td> </td> <td> </td> <td> </td> </tr> <tr> <td> </td> <td> </td> <td> </td> </tr> <tr> <td> </td> <td> </td> <td> </td> </tr> <tr> <td> </td> <td> </td> <td> </td> </tr> <tr> <td> </td> <td> </td> <td> </td> </tr> </tbody> </table>	No.	DATE	DESCRIPTION																											
No.	DATE	DESCRIPTION																													
<p>PLAN DATE                  01-18-22                  04-20-22                  06-02-23</p>	<p>REVISIONS</p>																														

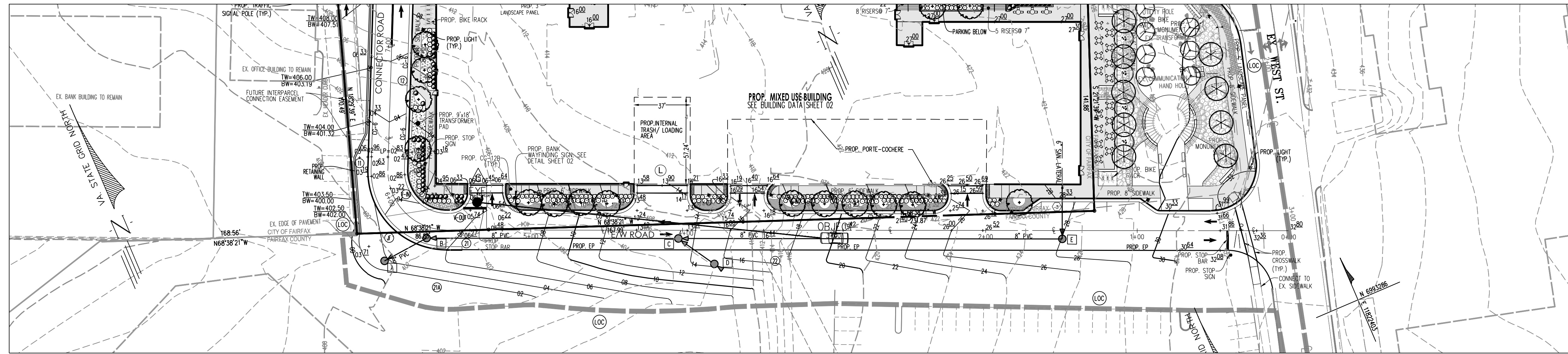

PLAN VIEW  
SCALE: 1"=40'

SIGHT DISTANCE PROFILE  
MAIN ENTRANCE ON WEST ST.  
EYE "C"  
RIGHT TURN ONLY  
POSTED SPEED = 10 MPH  
PROFILE SCALE: H:1"=50'; V:1"=5'

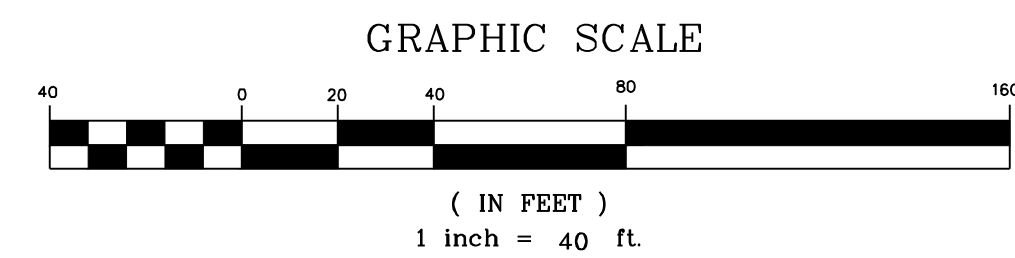
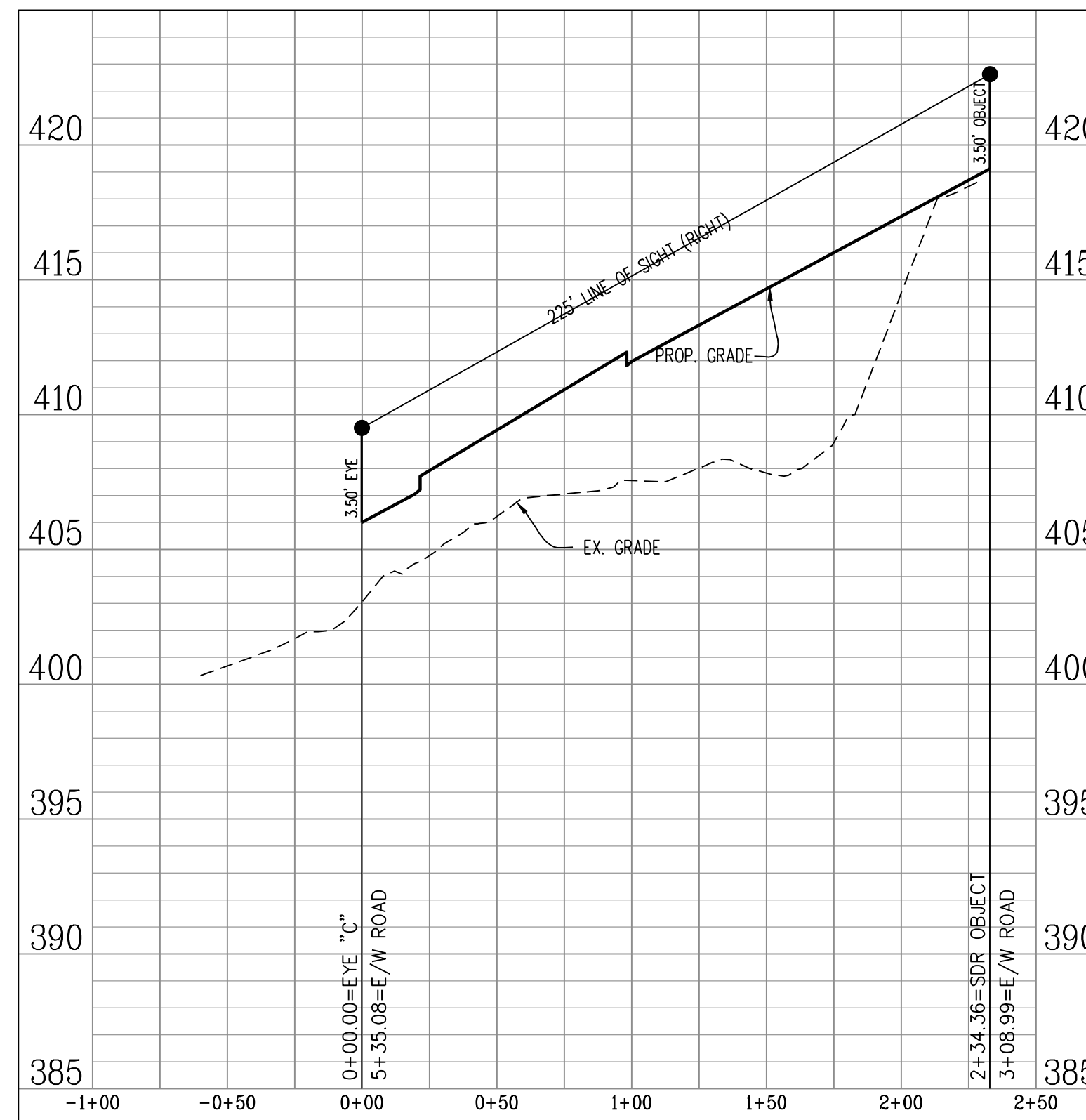

NOTE: TREES AND LANDSCAPING WITHIN THE SIGHT DISTANCE TRIANGLE WILL BE PRUNED AND LIMBED UP TO 6' TO MAINTAIN ADEQUATE SIGHT DISTANCE.

Urban, Ltd. - J:\085\10523 main street\p-engineering\entitlement\cdp-fdr-spec\13007-31-SIGHT.Dwg [SIGHT.D] June 02, 2023 - 10:53am velosr

No.	DATE	DESCRIPTION

PLAN DATE
01-18-22
04-20-23
06-02-23

Urban, Ltd.  
4000 D TECHNOLOGY CT.  
CHANTILLY, VA, 20151  
TEL: 703.642.2306  
FAX: 703.642.1888  
www.urban-lltd.com

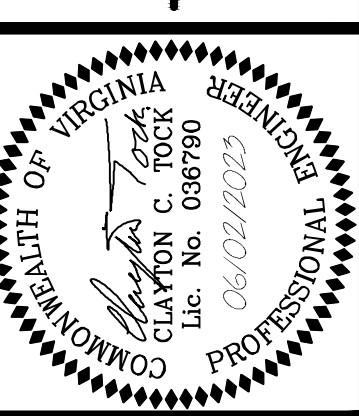
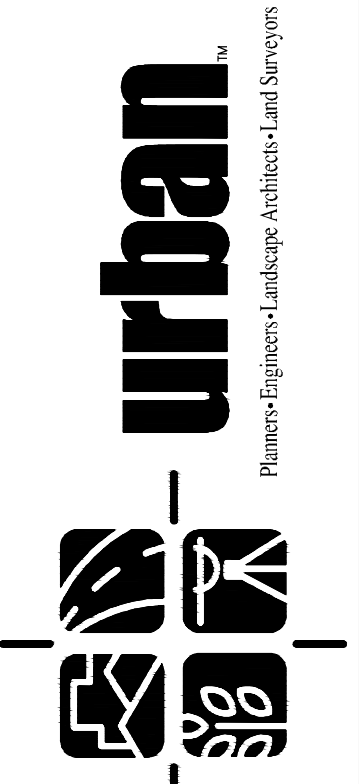

SIGHT DISTANCE PROFILES  
CITY CENTRE WEST  
GENERAL DEVELOPMENT PLAN  
SPECIAL USE PERMIT PLAN  
CITY OF FAIRFAX, VIRGINIA  
SCALE: AS NOTED  
DATE: JAN., 2022  
C.I.= 2'

SHEET  
29  
OF  
51  
FILE No.  
RZ-12907

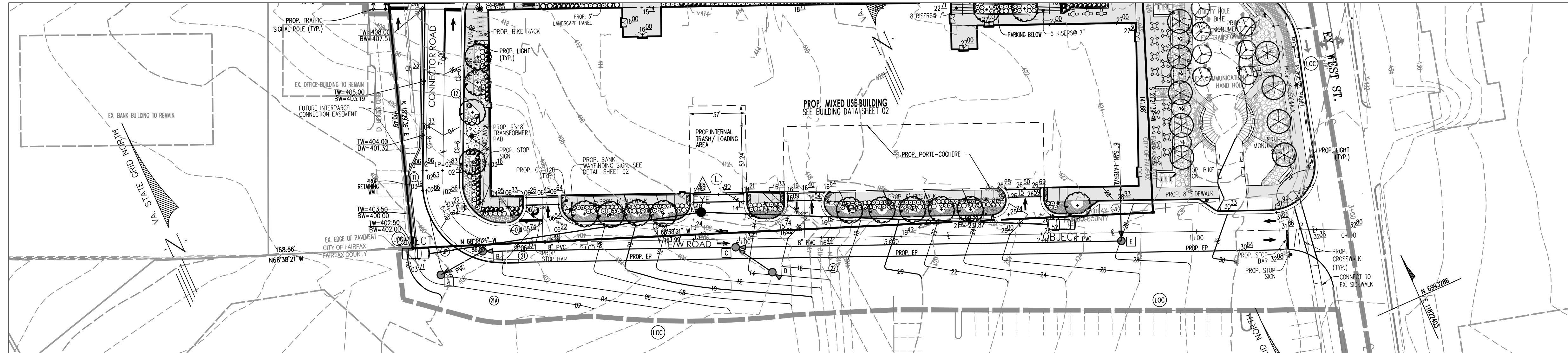

SIGHT DISTANCE PROFILE  
 MAIN ENTRANCE ON WEST ST.  
 EYE "D"  
 POSTED SPEED = 10 MPH  
 PROFILE SCALE: H:1"=50'; V:1"=5'

PLAN VIEW  
 SCALE: 1"=40'

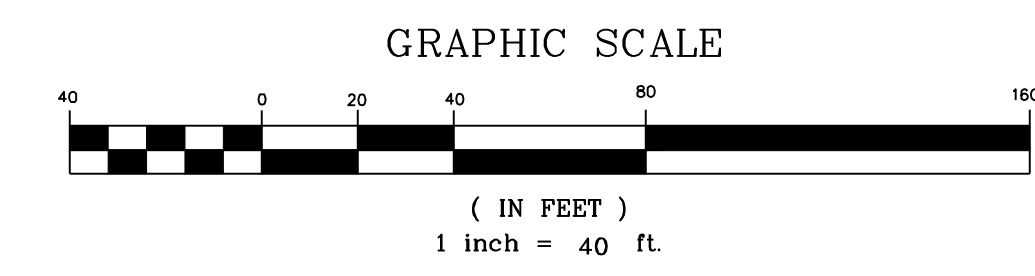
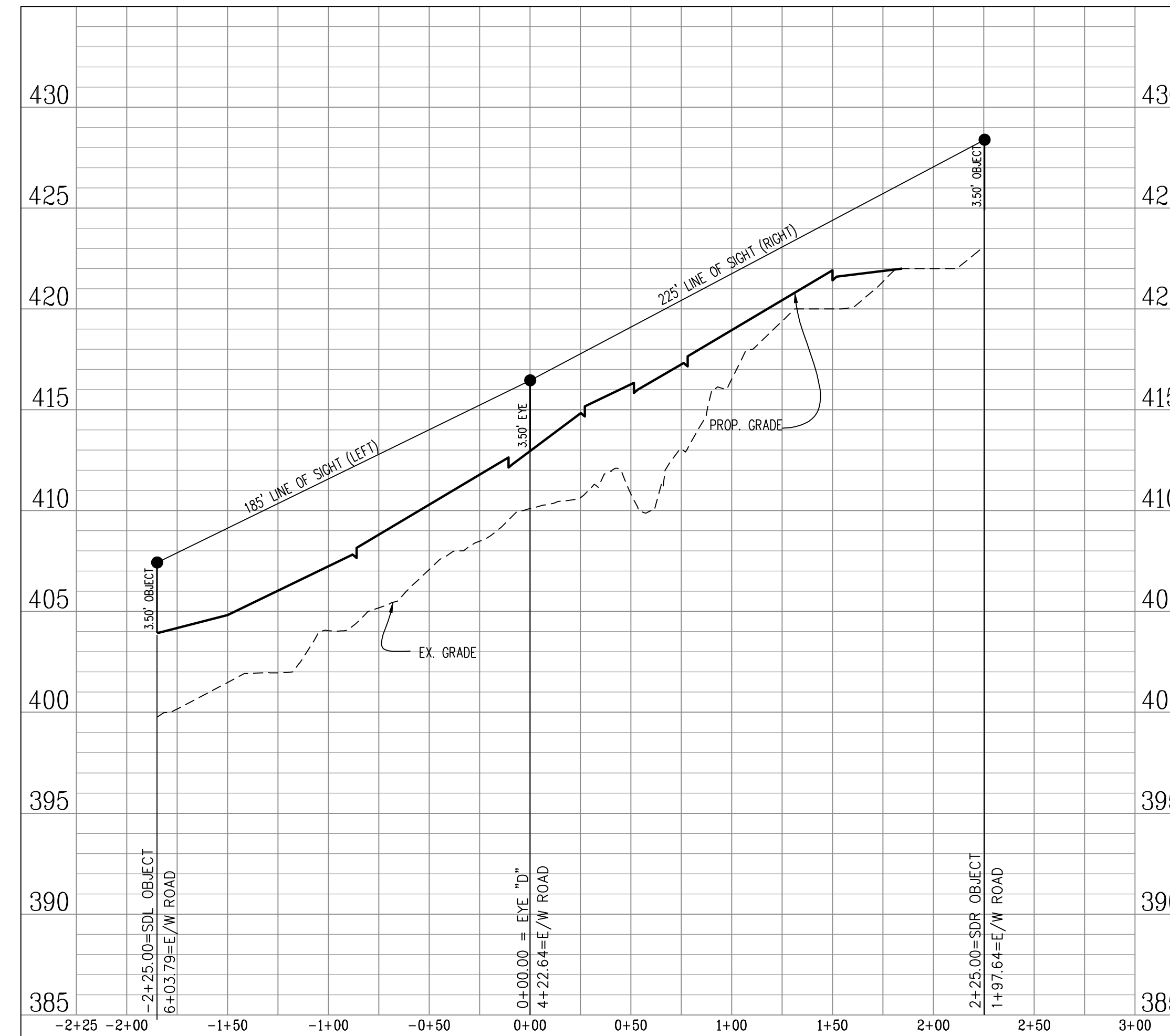

NOTE: TREES AND LANDSCAPING WITHIN THE SIGHT DISTANCE TRIANGLE WILL BE PRUNED AND LIMBED UP TO 6' TO MAINTAIN ADEQUATE SIGHT DISTANCE.

Urban, Ltd. - J:\085\0523 main street\engineering\entitlement\cdp-fdr-spec\13007-31-SIGHT.D.dwg [SIGHT.D (4)] June 02, 2023 - 10:53am velsor

Urban, Ltd. 4000 TECHNOLOGY CT. CHANTILLY, VA. 20151 TEL. 703.642.2306 FAX 703.642.1888 www.urban-llc.com		<b>urban</b> Planners • Engineers • Landscape Architects • Land Surveyors
SIGHT DISTANCE PROFILES <b>CITY CENTRE WEST</b> GENERAL DEVELOPMENT PLAN SPECIAL USE PERMIT PLAT CITY OF FAIRFAX, VIRGINIA		
SCALE: AS NOTED C.I.= 2'		DATE: JAN., 2022
SHEET 30 OF 51		REVISIONS No. DATE DESCRIPTION
FILE No. RZ-12907		



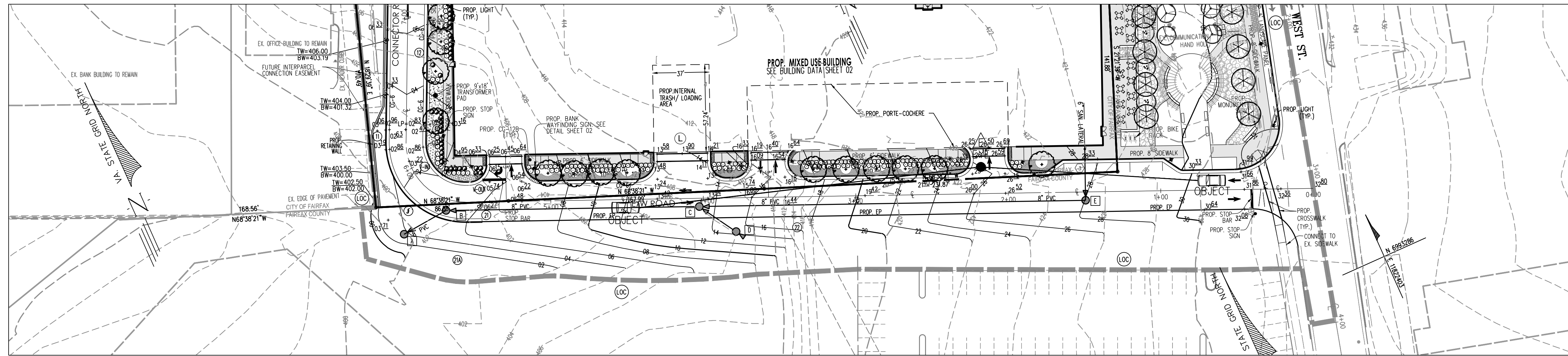

PLAN VIEW  
SCALE: 1"=40'

SIGHT DISTANCE PROFILE  
MAIN ENTRANCE ON WEST ST.  
EYE "E"  
POSTED SPEED = 10 MPH  
PROFILE SCALE: H:1"=50'; V:1"=5'

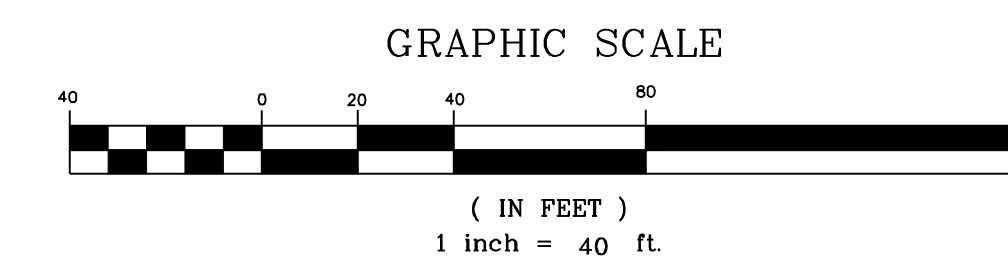
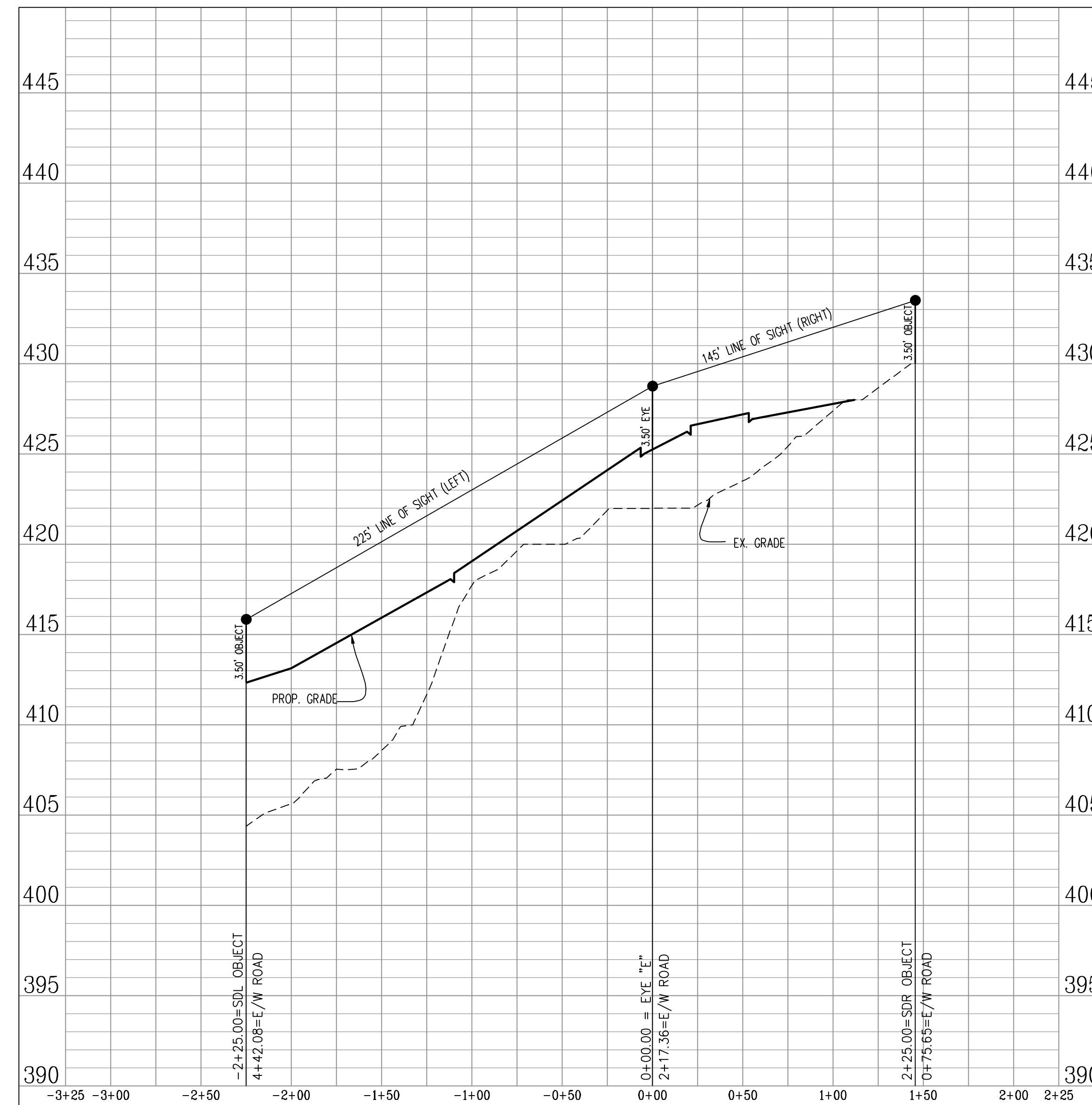

NOTE: TREES AND LANDSCAPING WITHIN THE SIGHT DISTANCE TRIANGLE WILL BE PRUNED AND LIMBED UP TO 6' TO MAINTAIN ADEQUATE SIGHT DISTANCE.

Urban, Ltd. - J:\085\10523 main street\engineering\entitlement\cdp-fdr-spec\13007-31-SIGHT.Dwg [SIGHT.DWG] June 02, 2023 - 10:53am velsor

<p>Urban, Ltd. 4000 TECHNOLOGY CT. CHANTILLY, VA, 20151 TEL: 703.642.2306 FAX: 703.678.1888 www.urban-llc.com</p> <p><b>urban</b> Planners • Engineers • Landscape Architects • Land Surveyors</p>							
<p>PLAN DATE 01-18-22 04-20-23 06-02-23</p>	<p>REVISIONS</p> <table border="1"> <thead> <tr> <th>No.</th> <th>DATE</th> <th>DESCRIPTION</th> </tr> </thead> <tbody> <tr> <td> </td> <td> </td> <td> </td> </tr> </tbody> </table>	No.	DATE	DESCRIPTION			
No.	DATE	DESCRIPTION					
<p>COMMONWEALTH OF VIRGINIA CLAYTON C. TOCK Lic. No. 098790 06/02/2023 PROFESSIONAL ENGINEER</p>							
<p>SIGHT DISTANCE PROFILES CITY CENTRE WEST GENERAL DEVELOPMENT PLAN SPECIAL USE PERMIT PLAT CITY OF FAIRFAX, VIRGINIA</p>							
<p>SCALE: AS NOTED</p>	<p>DATE: JAN., 2022</p>						
<p>SHEET 31 OF 51</p>	<p>FILE No. RZ-12907</p>						

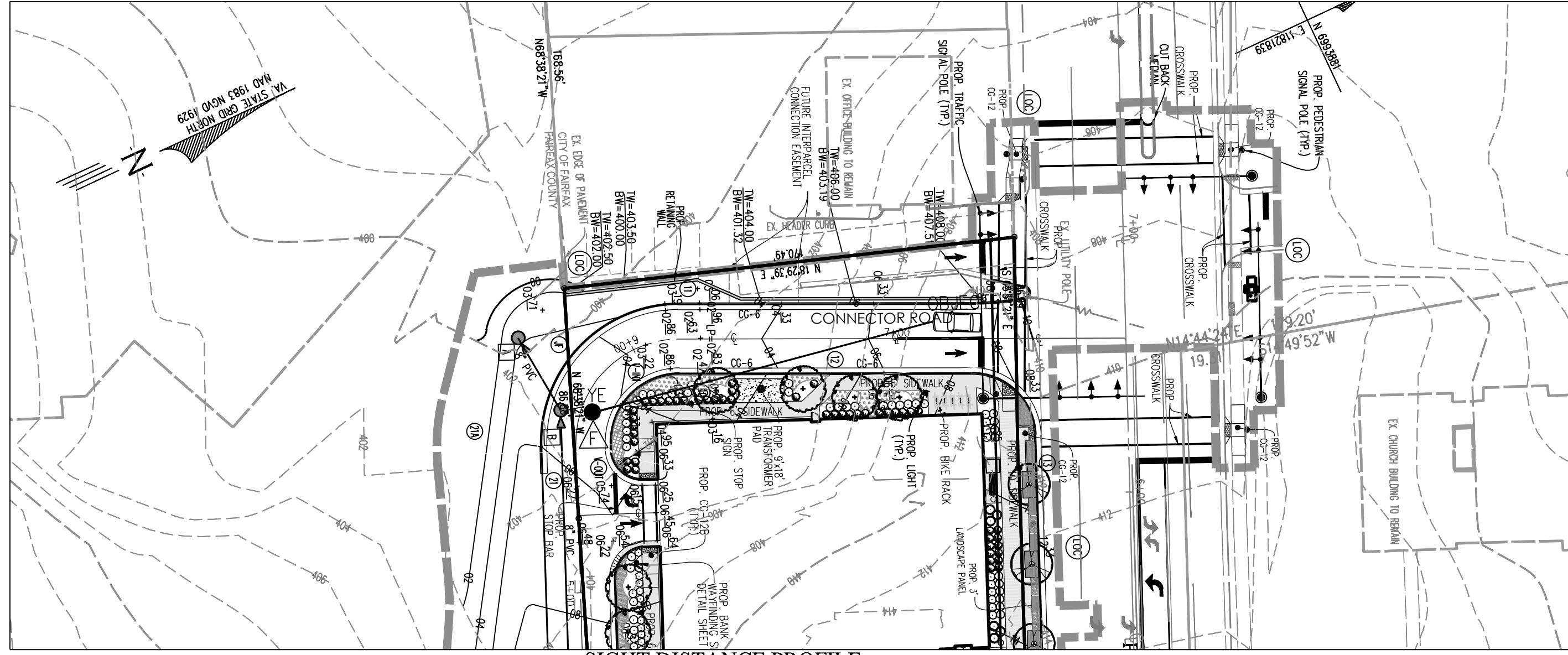

**SIGHT DISTANCE PROFILE  
MAIN ENTRANCE ON WEST ST.**

EYE "F"  
POSTED SPEED = 10 MPH  
PROFILE SCALE: H:1"=50'; V:1"=5'

**PLAN VIEW  
SCALE: 1"=40'**

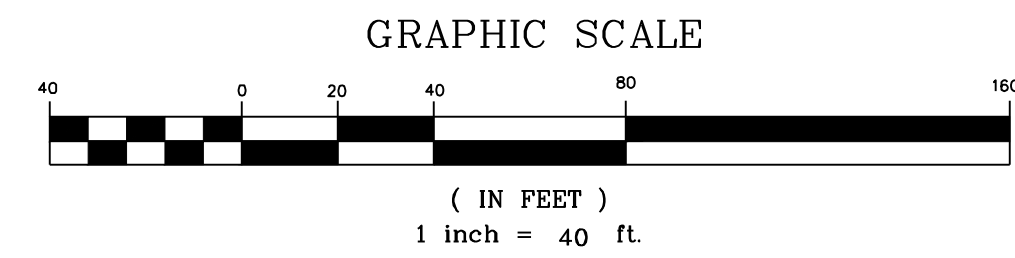
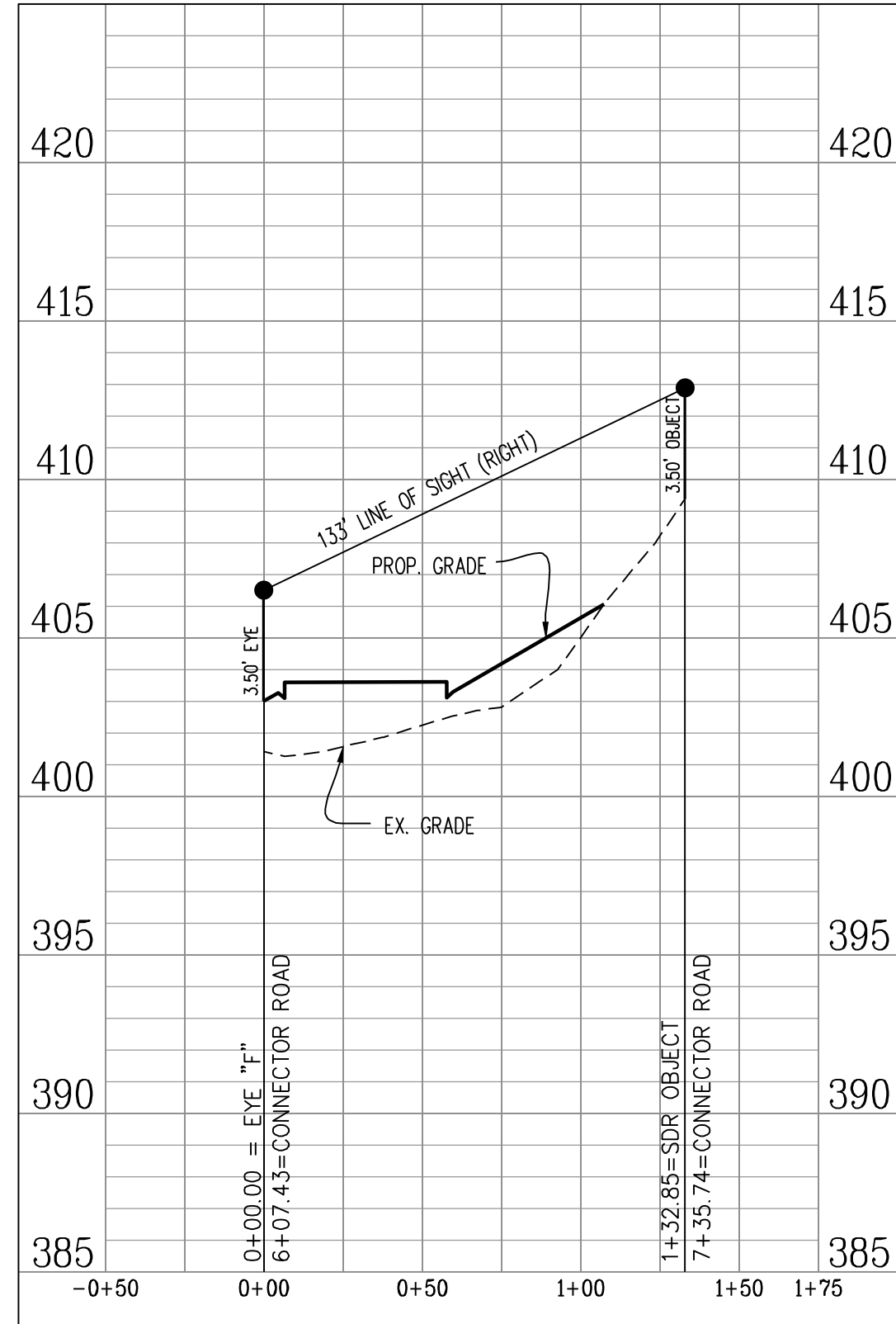

NOTE: TREES AND LANDSCAPING WITHIN THE SIGHT DISTANCE TRIANGLE WILL BE PRUNED AND LIMBED UP TO 6' TO MAINTAIN ADEQUATE SIGHT DISTANCE.

**SIGHT DISTANCE PROFILES  
CITY CENTRE WEST  
GENERAL DEVELOPMENT PLAN  
SPECIAL USE PERMIT PLAT  
CITY OF FAIRFAX, VIRGINIA**

SCALE: AS NOTED C.I.= 2' DATE: JAN., 2022

SHEET  
32  
OF  
51

FILE No.  
RZ-12907

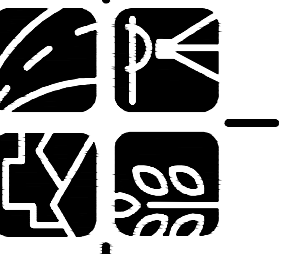
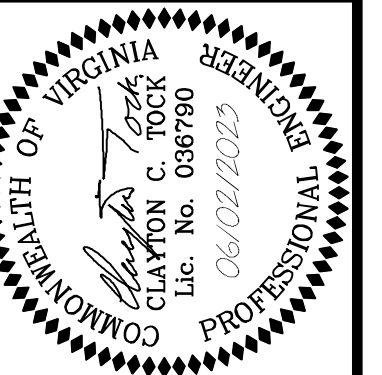

**urban**  
Planners • Engineers • Landscape Architects • Land Services

Urban, Ltd.  
4000 D TECHNOLOGY CT.  
CHANTILLY, VA, 20151  
TEL: 703.642.2306  
FAX: 703.642.2308  
www.urban-lltd.com

PLAN DATE	DESCRIPTION
01-18-22	
04-20-23	
06-02-23	

No.	DATE	DESCRIPTION

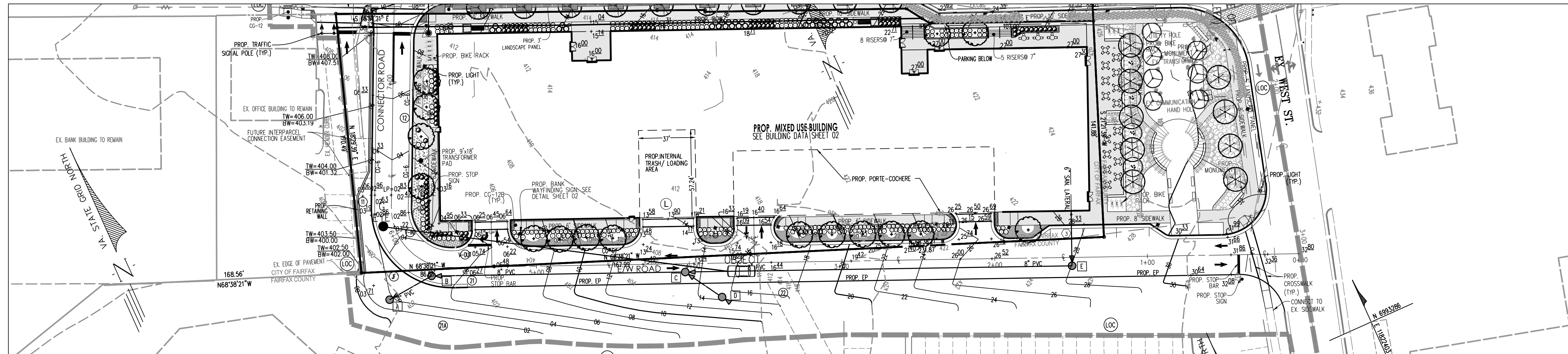

SIGHT DISTANCE PROFILE  
MAIN ENTRANCE ON WEST ST.

EYE "G"  
POSTED SPEED = 10 MPH  
PROFILE SCALE: H:1"=50'; V:1"=5'

PLAN VIEW  
SCALE: 1"=40'

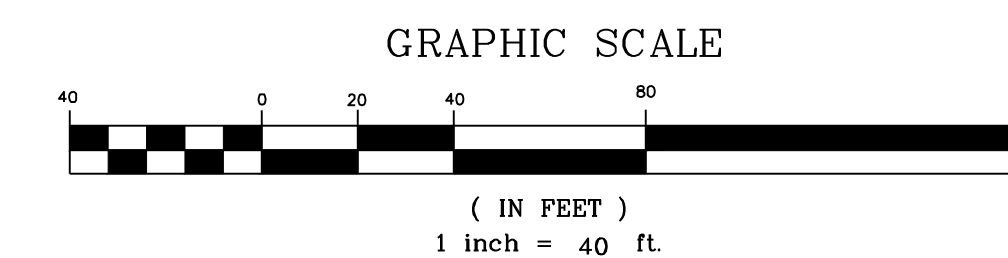
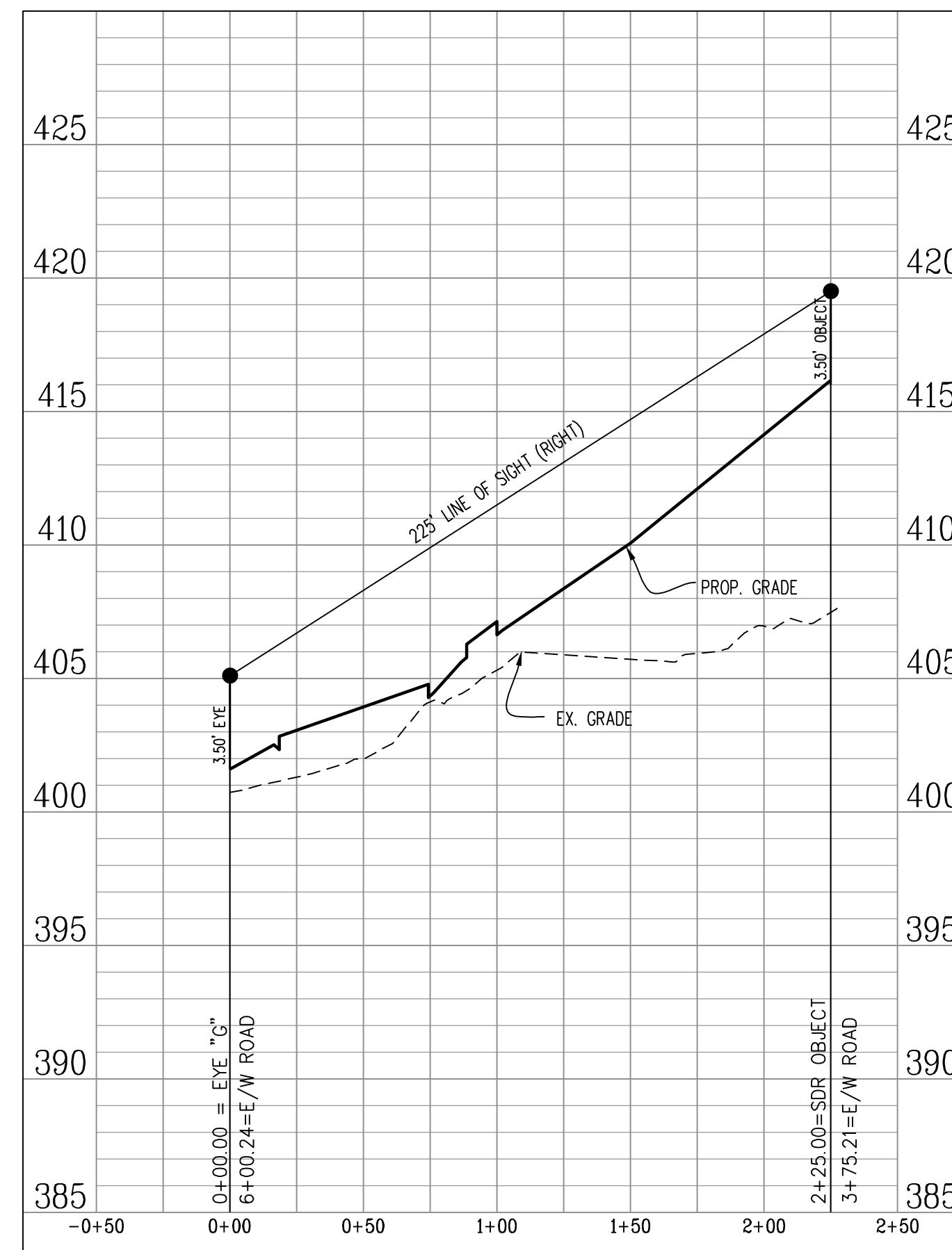

NOTE: TREES AND LANDSCAPING WITHIN THE SIGHT DISTANCE TRIANGLE WILL BE PRUNED AND LIMBED UP TO 6' TO MAINTAIN ADEQUATE SIGHT DISTANCE.

Urban, Ltd. - J:\085\10523 main street\engineering\entitlement\cdp-fdr-spec\13007-31-SIGHT.Dwg [SIGHT.D] June 02, 2023 - 10:53am velsor

No.	DATE	DESCRIPTION

PLAN DATE
01-18-22
04-20-22
06-02-23

Urban, Ltd.  
4000 TECHNOLOGY CT.  
CHANTILLY, VA, 20151  
TEL: 703.642.2306  
FAX: 703.642.1888  
www.urban-lltd.com

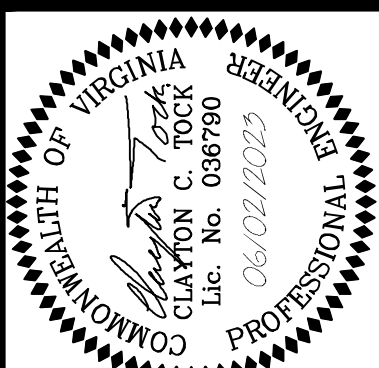
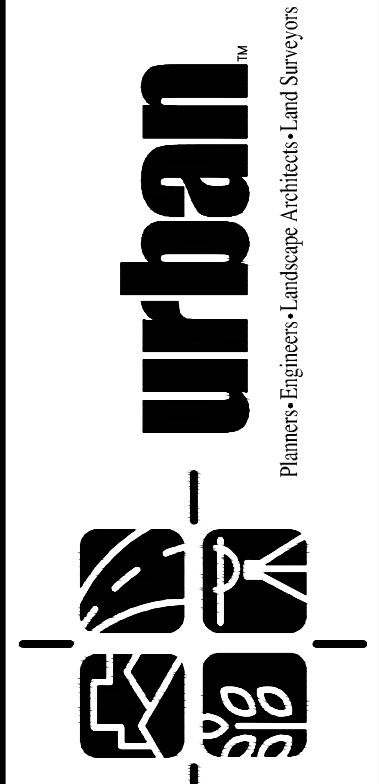

SIGHT DISTANCE PROFILES  
CITY CENTRE WEST  
GENERAL DEVELOPMENT PLAN  
SPECIAL USE PERMIT PLAT  
CITY OF FAIRFAX, VIRGINIA

SCALE: AS NOTED  
DATE: JAN., 2022  
C.I.= 2

SHEET  
33  
OF  
51  
FILE No.  
RZ-12907