



CITY
CENTRE
WEST

AN OX HILL PROPERTY

CERTIFICATE OF APPROPRIATENESS

Material and Fixture Product Information



A1

A2

CALCIUM SILICATE BRICK

Our unique brick story.

Brick. A natural, enduring and beloved building material made using clay all over the world. But Arriscraft brick is different. We make our calcium silicate brick using the same unique process as our Building Stone; we combine sand and lime that bonds naturally into an inherently strong and beautiful product. The result? A high-performance brick with through-body color and a distinct fine grain finish.

Our manufacturing expertise lets us offer a wide range of brick styles, from very long and modern to traditionally sized, tumbled options.

Residences at Pier 4 | SHoP Architects
Architectural Linear Series Opal
Photo: SHoP Architects

Brick





Denizen Bushwick | ODA New York
Architectural Linear Series Brick Charcoal
Photo: ODA Architecture

ARCHITECTURAL LINEAR SERIES BRICK

A distinctive brick with a weathered finish that is quickly making its mark. Explore a range of designer colors, creative installation options and a split face finish option.

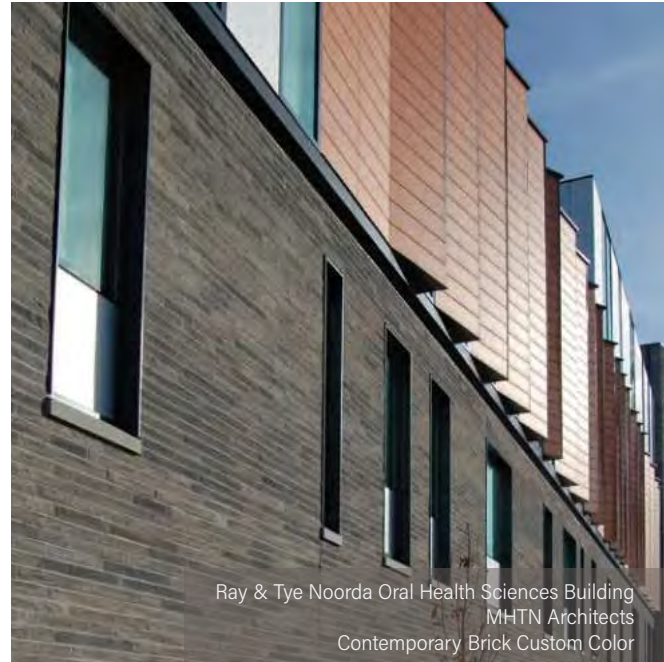

Ray & Tye Noorda Oral Health Sciences Building
MHTN Architects
Contemporary Brick Custom Color

CONTEMPORARY BRICK

Create long, modern lines with this gorgeous over-sized brick available in a wide color range from very dark to white. Combine colors for an eye-catching finish.



Tumbled Vintage Brick Mystic Grey
Photo: Langen Studios

TUMBLED VINTAGE BRICK

For an elegant yet charming aesthetic, choose our Tumbled Vintage Brick. Naturally tumbled edges offer extra authenticity to your traditional designs.



Tumbled Georgia Brick Sandy Shore

TUMBLED GEORGIA BRICK

Our newest brick introduction, this standard brick size features our distinct fine grain finish and comes in two trendy colors.



The Chestnut at University City | SITIO architecture + urbanism
Linear Series Obsidian Split & Smooth
Photo: Powelton Digital Media Group



PRODUCT DESCRIPTION

BASIC USE Calcium Silicate Masonry Products used in full-bed masonry veneer construction. For interior and exterior use in residential, commercial and institutional applications.

For thin-clad calcium silicate products, refer to refer to **ARRISCRAFT•DATA** 04 43 13.16 Thin-Clad Adhered Masonry Veneer Assembly—Thin-Clad Units.

COMPOSITION AND MATERIAL Calcium Silicate Masonry Products describes Renaissance® Masonry Units, Evolution Masonry Units, Calcium Silicate Building Stone, and Calcium Silicate Brick. Calcium Silicate Masonry Products are manufactured calcium silicate units containing no Portland cement. They are pressure-formed and autoclave cured, resulting in high-density, severe weathering modular units, with one or more finished faces. Refer to **ARRISCRAFT•NOTE – Calcium Silicate Masonry Units** for further information. The units may be site cut, trimmed and finished to custom lengths, shapes or sizes, as required on site.

SHAPES AND SIZES Cambridge produced Renaissance® Masonry Units are available in a variety of standard shapes and sizes:

Code	Height	Length	Bed
REN358	3-5/8"	23-5/8"	3-5/8"
REN758	7-5/8"	23-5/8"	3-5/8"
REN1158	11-5/8"	23-5/8"	3-5/8"

Renaissance® Masonry Units are also available in custom shapes and sizes, up to a maximum length of 23-5/8" and face rise of 11-5/8". Bed depths are limited to a maximum of 3-5/8" with rocked faced finishes and 4-5/8" with smooth faced finishes. Profiles such as margins, chamfers, notches and bullnoses are available at a premium price. Refer to the Renaissance® Custom Profile Guide for further information or contact your local Arriscraft representative or dealer.

A factory applied coating may be present on the long mortar beds of the units. Consider the need to order finished beds for application where they may be exposed.

Evolution Masonry Units are available in a variety of standard sizes:

Code	Height	Length	Bed
ELN35	3-5/8"	31-5/8"	3-5/8"
ELN75	7-5/8"	31-5/8"	3-5/8"

Evolution Masonry Units are also available in custom shapes and sizes, up to a maximum length of 31-5/8" and face rise of 7-5/8". Bed depths are limited to a maximum of 3-5/8" with smooth faced finishes. Profiles such as margins, chamfers, notches and bullnoses are available at a premium price. Contact your local Arriscraft representative or dealer for further information.

Calcium Silicate Building Stone (Cambridge, Ontario) is available in a variety of standard sizes:

Code	Height	Length	Bed
Citadel® Building Stone		Texture: Tumbled finish	
CIT/FRE23	2-3/8"	Various lengths up to 23-5/8"	3-5/8"
CIT36	3-13/16"	Various lengths up to 23-5/8"	3-5/8"
CIT52	5-1/4"	Various lengths up to 23-5/8"	3-1/2"
CIT81	8-1/8"	Various lengths up to 23-5/8"	3-1/2"
Edge Rock Building Stone		Texture: Split-faced finish	
SHA/UL50	4-15/16"	Various lengths up to 31-5/8"	3-1/4" ± 1/4"
EDG102	10-1/4"	Various lengths up to 23-5/8"	3-1/2" ± 1/2"
Fresco Building Stone		Texture: Split-faced and Tumbled finish	
CIT/FRE23	2-3/8"	Various lengths up to 23-5/8"	3-5/8"
FRE52	5-1/4"	Various lengths up to 23-5/8"	3-1/2"
FRE81	8-1/8"	Various lengths up to 23-5/8"	3-1/2"
Laurier Building Stone		Texture: Rocked finish	
LAU23	2-3/8"	Various lengths up to 23-5/8"	3-3/4"
LAU52	5-1/4"	Various lengths up to 23-5/8"	3-1/2"
LAU81	8-1/8"	Various lengths up to 23-5/8"	3-1/2"
LAU11	11"	Various lengths up to 23-5/8"	3-1/2"
Shadow Stone® Building Stone		Texture: Split-faced finish	
SHA/UL22	2-5/16"	Various lengths up to 23-5/8"	3-5/8" ± 1/4"
SHA/UL50	4-15/16"	Various lengths up to 31-5/8"	3-1/4" ± 1/4"
SHA75S	7-5/8"	Various lengths up to 23-5/8"	3-3/8" ± 1/4"
Urban LedgeStone		Texture: Split-faced finish	
SHA/UL22	2-5/16"	Various lengths up to 23-5/8"	3-5/8" ± 1/4"
UL35	3-5/8"	Various lengths up to 31-5/8"	3-1/4" ± 1/4"
SHA/UL50	4-15/16"	Various lengths up to 31-5/8"	3-1/4" ± 1/4"

Calcium Silicate Building Stone (Fort Valley, Georgia) is available in a variety of standard sizes:

Code	Height	Length	Bed
Georgia Citadel® Building Stone		Texture: Tumbled finish	
GC22	2-1/4"	Various lengths up to 23-5/8"	3-7/8"
GC35	3-5/8"	Various lengths up to 23-5/8"	3-5/8"
GC47	4-7/8"	Various lengths up to 23-5/8"	3-1/2"
GC75	7-5/8"	Various lengths up to 23-5/8"	3-3/4"
Coastal Building Stone		Texture: Split or Sawn Finish	
COA21	2-1/8"	Fragmented lengths up to 23-5/8"	2-7/8" ± 1/8"
COA35	3-5/8"	Fragmented lengths up to 23-5/8"	2-7/8" ± 1/8"
COA62	6-1/8"	Fragmented lengths up to 23-5/8"	2-7/8" ± 1/8"
Highfalls LedgeStone		Texture: Split-faced Finish	
HFL22	2-1/4"	Various lengths up to 23-5/8"	3-13/16"
HFL47	4-7/8"	Various lengths up to 23-5/8"	3-13/16"
HFL75	7-5/8"	Various lengths up to 23-5/8"	3-13/16"
Matterhorn Building Stone		Texture: Split-faced Finish	
MAT50	4-15/16"	Various lengths up to 23-5/8"	3-7/16" ± 1/2"
MAT102	10-1/4"	Various lengths up to 23-5/8"	3-1/2" ± 1/2"
Midtown Building Stone		Texture: Split or Sawn Finish	
MID21	2-1/8"	Fragmented lengths up to 23-5/8"	2-7/8" ± 1/8"
MID35	3-5/8"	Fragmented lengths up to 23-5/8"	2-7/8" ± 1/8"
MID57	5-7/8"	Fragmented lengths up to 23-5/8"	2-7/8" ± 1/8"
Old Country Building Stone		Texture: Split-faced finish	
OC22	2-1/4"	Various lengths up to 23-5/8"	3-13/16"
OC35	3-5/8"	Various lengths up to 23-5/8"	3-13/16"
OC47	4-7/8"	Various lengths up to 23-5/8"	3-13/16"

Shipped material also includes a percentage of shorter random length units which can be used by the installer in creating the ashlar bond patterns and around openings and at internal corners. Contact your local Arriscraft representative or dealer for additional information.

Calcium Silicate Brick is available in a variety of standard sizes:

Cambridge, Ontario produced Brick

Code	Height	Length	Bed
Contemporary Brick		Texture: Split-faced finish	
CON31	3-1/8"	Various lengths up to 30-3/8"	3-1/2"
Tumbled Vintage Brick		Texture: Tumbled finish	
TVB31	3-1/8"	10-1/8"	3-1/2"
Architectural Linear Series Brick		Texture: Weathered finish	
LS22	2-1/4"	Various lengths up to 23-5/8"	3-3/4"

Fort Valley, Georgia produced Brick

Code	Height	Length	Bed
Tumbled Georgia Brick		Texture: Tumbled finish	
TVB31	2-3/4"	7-5/8"	2-5/8"
Architectural Linear Series Brick		Texture: Weathered finish	
LS22	2-1/4"	Various lengths up to 23-5/8"	3-3/4"

TOLERANCES Calcium Silicate Masonry Products are fabricated to the following tolerances:

Renaissance® Masonry Units and Evolution Masonry Units:

- Unit Height and Length: +/- 1/16".
- Deviation from square, with the measurement taken using the longest edge as the base: +/- 1/16".
- Unit Bed: +/- 1/8".
- **Custom Unit Dimensions: 1/8".**

Finished unit heads can be custom ordered or finished on site by the contractor. With Sandblasted finish, about 15% of units randomly placed on skids come with one acceptable head. Units ordered with finished heads will deviate from the standard dimension. Expected deviations when ordering finished heads are as follows:

Finished Heads		
Finish	Number of Finished Heads	Reduction in Unit Length
Sandblasted*	1-2	3/8"—3/4"
Rocked	1-2	3/4"—1-1/2"

*Evolution Masonry Units supplied in Sandblasted finish only.

Due to the nature of these finishing operations, the custom dimensions tolerance of +/- 1/8" will apply.

Calcium Silicate Building Stone and Calcium Silicate Brick:

- Unit Height: +/- 1/16".
- Unit Bed: +/- 1/8".

Split, rocked, or tumbled units, by the nature of their random finish, may have dimensional variations exceeding these values.

Units shall exhibit a texture approximately equal to the approved sample when viewed under diffused daylight illumination at a 20 foot distance. Minor chipping resulting from shipment and delivery shall not be grounds for rejection. Minor chips shall not be obvious under diffused daylight illumination from a 20 foot distance.

Chips found on *unfinished* faces are not grounds for rejection.

Split and rocked faces are inspected for cracks and blemishes only, as chippage considerations do not apply when the desired surface texture and unit shape are intended to be uneven.

LIMITATIONS Manufactured masonry products are generally intended for above grade installations. Manufactured masonry veneer units, regardless of their composition, are inherently absorptive, and as such, are not intended for use below grade. Manufactured units installed below grade will wick moisture from the soil that is in contact with the masonry units and create a condition known as "rising damp" in the masonry veneer.

In colder climates, masonry walls at grade may become exposed to de-icing compounds. As with other types of manufactured masonry units, calcium silicate masonry units should not be installed where they will be directly exposed to de-icing compounds used to melt snow and ice from pavements.

The function of caps and copings is to prevent moisture from entering the building envelope through the top of the wall. As most manufactured masonry units are produced in relatively short lengths, if they are used as a cap or coping material the more mortar joints are required between the individual



units. These mortar joints are the most likely entry point for moisture to infiltrate the building envelope. As such, it is generally recommended within the industry that longer components, such as quarried stone, cast stone, or metal parapet cap flashing be used to reduce the number of joints thereby limiting the areas that may allow moisture infiltration of the building envelope.

COLORS AND PATTERNS Renaissance® Masonry Units are available in the following standard colors:

Cambridge, Ontario standard colors and finishes

Color		Finish	
		Sandblasted	Rocked
Monochromatic Range	Blacksmith	•	•
	Carbon	•	•
	Wheat	•	•
	White	•	•
Striated	Nutmeg	•	•
	Olive	•	•
Range	Barnboard	•	•
	Birchbark	•	•
	Driftwood	•	•
	Ironstone	•	•
	Sandrift	•	•

Fort Valley, Georgia standard colors and finishes

Color		Finish		
		Smooth	Rocked	Satin
Monochromatic	Champagne	•	•	•
	Limestone	•	•	•
	Tan	•	•	•
Monochromatic Range	Café	•	•	•
Striated	Basalt	•	•	•
	Ginger	•	•	•
	Oak Ridge	•	•	•
Striated Range	Magnolia	•	•	•
	Montecito	•	•	•
	Mountain Ridge	•	•	•
	Redrock	•	•	•
	Sunset	•	•	•

Evolution Masonry Units are available from our Cambridge, Ontario manufacturing facility in the following standard colors:

Color		Finish
		Sandblasted
Monochromatic Range	Carbon	•
	Wheat	•
	White	•
Striated	Nutmeg	•

- Monochromatic colors consist of a single hue.
- Monochromatic range colors consist of a single hue with a subtle distribution of tones that vary from unit to unit.
- Striated colors are a multi-hued blend.
- Striated range colors are a multi-hued blend and will contain a distribution of colors or shades that vary from unit to unit.

Calcium Silicate Building Stone (Cambridge, Ontario) is available in the following standard colors:

Product	Colors
Citadel®	Cashmere, Charcoal, Driftwood, French Country, Infinity, Traditional Grey, Willow Breeze
Edge Rock	*Collingwood, Delta, Glacier, *Steel Grey
Fresco	Eclipse, Greige, Moonstone, Silverado, Traditional Grey, Twilight
Laurier	Charcoal, Ivory White, Mahogany, Midnight Grey, Opal, Walnut
Shadow Stone®	Avalanche, Collingwood, Driftwood, Steel Grey, Tacoma
Urban LedgeStone	Avalanche, Collingwood, Driftwood, Steel Grey, Tacoma

*Edge Rock in colors Collingwood and Steel Grey is offered in a SHAUL50 and EDG102 combination.

Calcium Silicate Building Stone (Fort Valley, Georgia) is available in the following standard colors:

Product	Colors
Georgia Citadel®	Cobble Hill, Indiana Blend, Mocha, Rockport, Savannah, Silver Slate, Weatherwood
Coastal	Amalfi, Baja, Cape Cod, Dark Shore, Monterey, White Cliff
Highfalls LedgeStone	Beech Mountain, Blackrock, Cloudland
Matterhorn	Augusta, Barnwood, Blueridge, Chalet, Cotton Creek, Saddle
Midtown	Abbey Road, Biscayne, Lombard, Manhattan, Newbury, Peachtree
Old Country	Big Horn, Smoky Mountain

Calcium Silicate Brick (Cambridge, Ontario) is available in the following standard colors:

Product	Colors
Contemporary Brick	Blizzard, Ivory White, Mystic Grey, Phoenix, Tofino
Tumbled Vintage Brick	Alpine White, Mystic Grey, Platinum Grey, Silver Mist, Weathered Oak
Architectural Linear Series Brick	Charcoal, Midnight Grey, Obsidian, Opal

Calcium Silicate Brick (Fort Valley, Georgia) is available in the following standard colors:

Product	Colors
Tumbled Georgia Brick	Sandy Shore, Southern Dusk
Architectural Linear Series Brick	Burnt Umber, Cedar Woods, Chateau Brown, Evening Shade, Forged Steel, Harbor Grey, Red Sumac, White Pearl

Refer to actual color samples and panels for final color selection. Colors within each product group may be blended in a wall to achieve a more natural appearance. Information pertaining to common color blends for each product line is available upon request. Not all colors within a product group are available in all sizes. Contact Arriscraft for a detailed listing of colors and sizes available.

Custom colors are also available for all Calcium Silicate Masonry Products on a minimum order basis. Contact your local Arriscraft representative or dealer for additional information.



As a manufactured product, Calcium Silicate Masonry Products are monitored for color consistency. Slight variations between batches may occur, and it is recommended that the installer mix units from different skids during installation.

FINISHES Standard surface finishes for Calcium Silicate Masonry Products include:

- Sandblasted finish: a matte textured, relatively fine-grained uniform smooth surface.
- Rocked finish: a surface finish resulting from mechanical splitting and hand-chiseling of the masonry unit to a set depth to achieve a bold rustic appearance.
- Satin finish: a uniform fine-grained finish similar to Sandblasted.
- Smooth finish: a finish achieved by lightly honing the surface with a mechanical, fine abrasive head in a wide, circular motion.
- Split-faced finish: a surface finish resulting from mechanically splitting a manufactured masonry unit to achieve a rough, stone-like texture. Some split-faced units may have split fronts and backs.
- Tumbled finish: a finish resulting from splitting, and either tumbling or mechanically aging the pieces to create the rusticated look.
- Weathered finish: a rusticated and bruised finish.

Consultants should review samples prior to selecting a particular color and finish.

TECHNICAL DATA

APPLICABLE STANDARDS Required properties for Calcium Silicate Masonry Products are described in ASTM C73, Standard Specification for Calcium Silicate Face Brick (Sand-Lime Brick). This standard classifies calcium silicate products as either moderate-weathering or severe-weathering depending on the material's tested physical properties of compressive strength and 24-hour absorption. Calcium Silicate Masonry Products meet and exceed the requirements necessary to comply with the severe-weathering classification.

INSTALLATION

DELIVERY Calcium Silicate Masonry Products are delivered to the site in protective packaging.

HANDLING Lift skids with proper and sufficiently long slings or forks with protection to prevent damage to units. Protect edges and corners. Depending on weather conditions (lots of rain, humid weather), we suggest removing the plastic stretch wrap from the skids to allow air to flow around the product. If this is done, the unwrapped skid will be less stable and subsequent handling of the skid of units must be done with great care.

STORAGE Upon delivery, isolate masonry units from contact with the ground, vegetation and other material to prevent staining. Stack the masonry units on timbers or platforms at least 3" above ground. Place polyethylene or other plastic film between wood and other finished surfaces of unpackaged units when stored for an extended period of time. Cover stored material with a tarp if it will be exposed to weather for an extended period of time.

Do not use salt to thaw ice formed on the surfaces of units.

PREPARATORY WORK It may be advantageous under hot, dry weather or windy conditions to pre-dampen the units prior to placement in the wall. Damp units should be surface dry at the time of placement.

When constructing masonry in hot or cold weather refer to the

ARRISCRAFT•TECH bulletins titled Hot Weather Masonry Construction and Cold Weather Masonry Construction.

INSTALLATION Calcium Silicate Masonry Products must be installed using approved materials and techniques for each specific installation. Refer to the **ARRISCRAFT•CADD Library for applicable details.**

Construct masonry veneer with an adequate number of elastic movement joints, properly located to accommodate differential movement. Refer to **ARRISCRAFT•NOTE – Building Movement Joints** for further information. Construct masonry veneer in accordance with TMS 402, Building Code Requirements for Masonry Structures, and any local requirements stipulated by the authorities having jurisdiction.

Mortar joints between units in any direction should be 3/8" thick, with the exception of Citadel® Building Stone, Fresco Building Stone, Laurier Building stone, and Georgia Citadel® Building Stone which utilize a 1/2" thick mortar joint. Mortar for calcium silicate masonry units should be a Type N Portland cement-lime mix, proportioned to a 1:1:6 ratio. This ratio refers to:

- 1 part Portland cement (ASTM C150, Type I).
- 1 part hydrated lime (ASTM C207, Type S - Special).
- 6 parts masonry sand (ASTM C144).

When properly combined with the appropriate quantity of water, it will produce a general-purpose mortar, exhibiting good workability and board life in its plastic state, and good durability and flexibility in its hardened state; and conforming to ASTM C270, Standard Specification for Mortar for Unit Masonry. **For further information, refer to ARRISCRAFT•NOTE – Mortar for Masonry Veneer.**

Arriscraft recommends constructing masonry veneer with proper drainage mechanisms, including clear draining air spaces, through wall flashing **membranes and weep hole vents. The air spaces must be at least 1" wide, and kept clear of debris, protrusions, mortar fins and droppings. Weep hole vents should be installed at the same level as through wall flashing membranes and spaced not more than 24" on center horizontally. Refer to ARRISCRAFT•NOTE – Moisture Management** for further information.

Calcium Silicate Masonry Products must be connected to a structural substrate with an approved masonry connection system, designed by the **consultant for each specific installation. Refer to ARRISCRAFT•NOTE – Connectors – Part I, Masonry Ties.**



BOND PATTERNS Calcium Silicate Building Stone are each installed using different bonding patterns. These are typically described as a percentage ratio, from the smallest to the largest units, as follows:

Product	2-Unit	3-Unit	4-Unit
Citadel®		20:40:40	20:20:40:20
Citadel® (no CIT36)		25:50:25	
Edge Rock	75:25		
Fresco		25:50:25	
Laurier		20:50:30	10:40:30:20
Shadow Stone®	60:40	20:50:30	
Urban LedgeStone (Ashlar)		20:50:30	
Georgia Citadel®		25:50:25	20:20:40:20
Coastal		30:55:15	
Highfalls LedgeStone		25:50:25	
Matterhorn	75:25		
Old Country		40:40:20	

If Urban LedgeStone, or Midtown using all three sizes, are installed in a coursed bond pattern, the ratio is 22:33:45.

Refer to Arriscraft's **Mason's Instructions** sheets for illustrations of each recommended bond pattern.

Standard bond patterns may also be modified by changing the ratio of small to large units. Contact your local Arriscraft representative or dealer for specific information on custom bond patterns.

AVAILABILITY AND COST

AVAILABILITY Calcium Silicate Masonry Products are available worldwide. Delivery times for orders will vary based on the complexity of what is required. Arriscraft cannot be responsible for delays due to fire, acts of God, or any other cause beyond its control or which could not be reasonably foreseen. Contact Arriscraft for a list of dealers in your area.

COST Quoted on a project basis for job-specific manufacturing to project requirements.

WARRANTY

Arriscraft warrants its products against deterioration for the life of the building, provided the products have been erected and used according to accepted masonry standards, within the guidelines of local building codes and as recommended by the manufacturer.

Complete warranty information is outlined on the Arriscraft standard form of Product Warranty.

MAINTENANCE

Although masonry is largely considered to be maintenance-free relative to other building materials, proper post-construction maintenance and care is crucial for creating long lasting and aesthetically pleasing masonry buildings. Some of the more common maintenance items are addressed in the Arriscraft **Care, Cleaning, and Maintenance** document, such as cleaning, repointing mortar joints, replacing silicone joints, scuff or chippage repairs, wall protection, cutting material, water repellents, and sealers.

Clean Calcium Silicate Masonry Products in accordance with the cleaning guidelines in the **Care, Cleaning, and Maintenance** document. Various proprietary masonry cleaning detergents and acid-based cleaning systems

may alter the color of Calcium Silicate Masonry Products. Always pre-test cleaning agents and methods on the job-site mock-up panel or a small, inconspicuous area of the wall. The Consultant and/or Owner should approve the test area prior to the start of full-scale cleaning operations.

Arriscraft does not recommend the application of water repellent or graffiti-proofing sealers to Calcium Silicate Masonry Products in exterior applications; however, they may be used for interior applications. For more information refer to the **Care, Cleaning, and Maintenance** document.

TECHNICAL SERVICES

Arriscraft offers consultation services to assist with the preparation of details, specifications and with pricing. Enquiries are addressed promptly and without obligation.

Arriscraft distributes an integrated technical information system including:

- **ARRISCRAFT•CADD:** sample details which are available in .dwg, .dxf, and .pdf formats.
- **ARRISCRAFT•DATA:** product data sheets.
- **ARRISCRAFT•NOTE:** technical discussions with respect to building construction issues
- **ARRISCRAFT•SPEC:** master guide specification sections.

All of these technical resources are available to be downloaded from the Arriscraft web site at www.arriscraft.com.

Arriscraft also makes available samples for color and finish, coursing charts and copies of test reports upon request.



Product Data Sheet

AkzoNobel Powder Coatings

Interpon D2525 Matt

Product Description

Interpon D2525 Matt is a series of ultra-durable powder coatings specifically formulated without TGIC, intended for use on architectural aluminium and galvanized steel. Providing new levels of weathering resistance **Interpon D2525 Matt** surpasses the performance of leading architectural powders. It offers significantly higher gloss retention and resistance to colour change combined with maximum film integrity to ensure long term cosmetic and functional protection.

These powder coatings are classified in Family I – class 6c under standard NFT 36-005.

Interpon D2525 Matt meets the requirements of GSB Master, Qualicoat Class 2, EN 12206 (formerly BS6496), EN13438 (formerly BS6497:1984) and AAMA 2604.

Some colours may not be available in **Interpon D2525 Matt**.

Following RAL shades are excluded from the RAL families for Qualicoat class 2: Ral 1003, 1028, 1033, 2004, 2011, 3015, 3017, 3018, 4001.

Qualicoat Licence number: P-1210 (France), P-1212 (Italy), P-1201 (UK), P-1512 (Turkey), P-1673 (Czech Republic), P-1244 (Egypt), P-1844(Russia)

GSB Licence number: 183b (gloss 25)

Powder Properties

Chemical type	Polyester
Appearance	Smooth Matt
Gloss level	20 - 30 gloss units
Particle Size	Suitable for electrostatic spray
Specific gravity	1.2-1.9 g/cm ³ depening on colour.
Storage	Dry, cool conditions (open boxes must be resealed)
Shelf life	24 months below 30°C peak temperature 12 months below 35°C peak temperature
Curing schedule (at object temperature)	15-35 minutes at 180°C 12-25 minutes at 190°C 10-20 minutes at 200°C

Powder on Powder application:

1st phase: Melting and partial curing of the base coat suggested 110-120°C for 15-20 min. (object temp) otherwise refer to the instruction of the spraying equipment supplier

2nd phase: Application of the wood decorative powder according to the instruction of the spraying equipment supplier

3rd phase: Complete curing of the full package for 10-20 minutes at 200°C (object temperature)

Mechanical Tests	Flexibility	ISO 1519 (cylindrical Mandrel)	Pass Qualicoat class 2 requirements	
	Adhesion	ISO 2409 (2mm Crosshatch)	Pass Gt0	
	Erichsen cupping	ISO1520	Pass Qualicoat class 2 requirements	
	Impact resistance	ISO 6272-2	Pass Qualicoat class 2 requirements	
	Hardness	ISO 2815	> 80	
	Mar Resistance Martindale Test (for X-Pro series)	CEN/TS 16611:2016	80 runs(5 cycles) Gloss Retention: 50-75% (depending on color)	
	Environmental and Durability Tests	Acetic Acid Salt Spray	ISO 9227	<16 mm ² corrosion/10cm (1000 hrs)
Constant Humidity		ISO 6270-2	No blistering, creep <1mm (1000 hrs)	
Sulphur Dioxide		ISO22479	Pass 24 cycles– no blistering, loss of gloss or discoloration	
Permeability		Pressure Cooker EN12206-1 Par. 5.10	Pass 1 hour, no blistering	
Chemical Resistance			Generally good resistance to acid, alkalis and oils at normal temperatures.	
Mortar Resistance		EN12206-1	No effect after 24 hours	
Accelerated Weathering		ISO16474-2 (1000 hrs) ISO11507 QUV B 313 (600 hrs)	≥90% Gloss retention ≥50% Gloss retention	
Exterior Durability		ISO 2810	Meets qualicoat class 2 requirements after 3 years Florida Meets AAMA 2604 requirements after 5 years Florida	
Test Conditions		Testing has been determined under laboratory conditions using the following application properties and is for guidance only.		
		Substrate	Aluminum (0.5-0.8 mm Al Mg1)	
	Pretreatment	Chrome free Qualicoat/GSB approved pretreatment		
	Film thickness	60-80 microns (ISO 2360)		
	Cure schedule	10 minutes at 200° C (object temperature)		
Actual film performance will depend on the individual circumstances in which the product is used.				

Pre-treatment

For maximum protection it is essential to pretreat components prior to the application of **Interpon D2525 Matt**.

Aluminium components should receive a full multi-stage chromate conversion coating or suitable chrome-free pre-treatment or suitable pre-anodising to clean and condition the substrate. Detailed advice should be sought from the pre-treatment supplier.

	<p>Interpon D2525 Matt products may also be used on cast or mild steel. For outdoor use Interpon Redox PZ anti-corrosive primer over a correctly prepared substrate is recommended</p>
Application	<p>Interpon D2525 Matt powders can be applied by manual or automatic electrostatic spray equipment. For solid shades, unused powder can be reclaimed up to a maximum of 30% using suitable equipment and recycled through the system. Please consult AkzoNobel for further details as to the correct mixing ratio for virgin/reclaim powder.</p> <p>Interpon D2525 Matt powders should be applied at minimum 60µm.</p> <p>All powders can show small color differences from batch to batch, this is normal and unavoidable. While AkzoNobel take every precaution to minimize visible differences, this cannot be guaranteed. Applicators and fabricators are advised to use a single batch for parts that will be assembled together. Differences are more likely with special effect powders.</p> <p>Bonded products have better application properties than blended products (more stable) but attention should still be paid to line settings in order to avoid “marble effect” and changes in aspect after recycling. A constant ratio between virgin and recycled powders should be fixed by the coater in order to achieve a consistent effect. For more information, it is suggested to read the <i>Metallic Applications Guidelines</i>.</p> <p>Products with different codes should not be mixed even if same colour and gloss.</p>
Post Application	<p>For specific advice on the suitability of post coating processes such as bending or the use of sealants, adhesives, thermal break, cleaning etc. Please consult AkzoNobel.</p>
Maintenance	<p>For specific advice on Cleaning and Maintenance, please consult the <i>Interpon D series Cleaning and Maintenance Guidelines</i> available from AkzoNobel.</p>
Safety Precautions	<p>Text as per local regulations</p>
Disclaimer	<p>IMPORTANT NOTE: The information in this data sheet is not intended to be exhaustive and is based on the present state of our knowledge and on current laws: any person using the product for any purpose other than that specifically recommended in the technical data sheet without first obtaining written confirmation from us as to the suitability of the product for the intended purpose does so at his own risk. It is always the responsibility of the user to take all necessary steps to fulfil the demands set out in the local rules and legislation. Always read the Material Data Sheet and the Technical Data Sheet for this product if available. All advice we give or any statement made about the product by us (whether in this data sheet or otherwise) is correct to the best of our knowledge but we have no control over the quality or the condition of the substrate or the many factors affecting the use and application of the product.</p> <p>Therefore, unless we specifically agree in writing otherwise, we do not accept any liability whatsoever for the performance of the product or for any loss or damage arising out of the use of the product. All products supplied and technical advices given are subject to our standard terms and conditions of sale. You should request a copy of this document and review it carefully. The information contained in this data sheet is subject to modification from time to time in the light of experience and our policy of continuous development. It is the user's responsibility to verify that this data sheet is current prior to using the product.</p> <p>Brand names mentioned in this data sheet are trademarks of or are licensed to AkzoNobel</p>

<http://www.interpon.com/contact-us/>

PRODUCT DATA SHEET

SikaSet® Mortar

Rapid-setting, portland-cement-based patching compound

PRODUCT DESCRIPTION

SikaSet® Mortar is a rapid-setting, portland-cement-based patching compound.

USES

- When mixed with water it can be used to patch concrete, brick, and stucco
- Excellent for basements, sumps, elevator pits, pools, tunnels, and sewers
- Vertical and horizontal surfaces
- Interior and exterior applications

CHARACTERISTICS / ADVANTAGES

- Use on dry, damp, or wet surfaces.
- Extended workability for tooling.
- Non-toxic, non-corrosive, non-rusting.
- Excellent resistance to freeze/thaw cycling.
- Rapid strength gain.

PRODUCT INFORMATION

Packaging	5 gal (50 lb = 22.6 kg) pail
Appearance / Color	Gray powder
Shelf Life	12 months from date of production if stored properly in original, unopened and undamaged sealed packaging
Storage Conditions	Store dry at 40–95 °F (4–35 °C) Protect from moisture. If damp, discard material

TECHNICAL INFORMATION

Compressive Strength	1 day	2,600 psi (18.0 MPa)	(ASTM C-109) 73 °F (23 °C) 50 % R.H.
	7 days	6,600 psi (45.5 MPa)	
Tensile Strength	7 days	400 psi (2.8 MPa)	(ASTM C-496) 73 °F (23 °C) 50 % R.H.
	28 days	700 psi (4.8 MPa)	

APPLICATION INFORMATION

Coverage	725 in ³ (70 mL) per bag (Coverage figures do not include allowance for surface profile and porosity or material waste)
Product Temperature	65–75 °F (18–24 °C)
Ambient Air Temperature	> 40 °F (4 °C)
Substrate Temperature	> 40 °F (4 °C)
Final Set Time	15 min (ASTM C-266)

APPLICATION INSTRUCTIONS

SURFACE PREPARATION

- Chip away soft, deteriorated, unsound substrate.
- Clean cavity completely. Lightly dampen the substrate just prior to application.

PRIMING

- **Reinforcing steel:** Steel reinforcement should be thoroughly prepared by mechanical cleaning to remove all traces of rust. Where corrosion has occurred due to the presence of chlorides, the steel should be high pressure washed with clean water after mechanical cleaning. For priming of reinforcing steel use Sika® Armatec® 110 EpoCem (consult PDS).
- **Concrete Substrate:** Prime the prepared substrate with a brush or sprayed applied coat of Sika® Armatec® 110 EpoCem (consult PDS). Alternately, a scrub coat of SikaSet® Mortar can be applied prior to placement of the mortar. The repair mortar has to be applied into the wet scrub coat before it dries.

MIXING

- Mix with clean water to obtain desired consistency.
- Do not over-mix.
- Do not over-wet.
- Do not re-temper.

APPLICATION

- Trowel into place.
- Knead into honeycombs with rubber-gloved hand.

LIMITATIONS

- Use only potable water for mixing.
- As with all cement based materials, avoid contact with aluminum to prevent adverse chemical reaction and possible product failure. Insulate potential areas of contact by coating aluminum bars, rails, posts etc. with an appropriate epoxy such as Sikadur® Hi-Mod 32.

BASIS OF PRODUCT DATA

Results may differ based upon statistical variations depending upon mixing methods and equipment, temperature, application methods, test methods, actual site conditions and curing conditions.

OTHER RESTRICTIONS

See Legal Disclaimer.

ENVIRONMENTAL, HEALTH AND SAFETY

For further information and advice regarding transportation, handling, storage and disposal of chemical products, user should refer to the actual Safety Data Sheets containing physical, environmental, toxicological and other safety related data. User must read the current actual Safety Data Sheets before using any products. In case of an emergency, call CHEMTREC at 1-800-424-9300, International 703-527-3887.

DIRECTIVE 2004/42/CE - LIMITATION OF EMISSIONS OF VOC

0 g/l (EPA method 24)

LEGAL DISCLAIMER

- KEEP CONTAINER TIGHTLY CLOSED
- KEEP OUT OF REACH OF CHILDREN
- NOT FOR INTERNAL CONSUMPTION
- FOR INDUSTRIAL USE ONLY
- FOR PROFESSIONAL USE ONLY

Prior to each use of any product of Sika Corporation, its subsidiaries or affiliates ("SIKA"), the user must always read and follow the warnings and instructions on the product's most current product label, Product Data Sheet and Safety Data Sheet which are available at usa.sika.com or by calling SIKA's Technical Service Department at 1-800-933-7452. Nothing contained in any SIKA literature or materials relieves the user of the obligation to read and follow the warnings and instructions for each SIKA product as set forth in the current product label, Product Data Sheet and Safety

Data Sheet prior to use of the SIKA product.

SIKA warrants this product for one year from date of installation to be free from manufacturing defects and to meet the technical properties on the current Product Data Sheet if used as directed within the product's shelf life. User determines suitability of product for intended use and assumes all risks. User's and/or buyer's sole remedy shall be limited to the purchase price or replacement of this product exclusive of any labor costs.

NO OTHER WARRANTIES EXPRESS OR IMPLIED SHALL APPLY INCLUDING ANY WARRANTY OF MERCHANTABILITY OR FITNESS FOR A PARTICULAR PURPOSE. SIKA SHALL NOT BE LIABLE UNDER ANY LEGAL THEORY FOR SPECIAL OR CONSEQUENTIAL DAMAGES. SIKA SHALL NOT BE RESPONSIBLE FOR THE USE OF THIS PRODUCT IN A MANNER TO INFRINGE ON ANY PATENT OR ANY OTHER INTELLECTUAL PROPERTY RIGHTS HELD BY OTHERS.

Sale of SIKA products are subject to the Terms and Conditions of Sale which are available at <https://usa.sika.com/en/group/SikaCorp/termsandconditions.html> or by calling 1-800-933-7452.

Sika Corporation

201 Polito Avenue
Lyndhurst, NJ 07071
Phone: +1-800-933-7452
Fax: +1-201-933-6225
usa.sika.com

Sika Mexicana S.A. de C.V.

Carretera Libre Celaya Km. 8.5
Fracc. Industrial Balvanera
Corregidora, Queretaro
C.P. 76920
Phone: 52 442 2385800
Fax: 52 442 2250537



Product Data Sheet

SikaSet® Mortar
August 2018, Version 01.01
020302040030000010

SikaSetMortar-en-US-(08-2018)-1-1.pdf



SunGuard® Advanced Architectural Glass

Our comprehensive range of coatings, colors and design solutions allows architects to explore fully the aesthetic and functional possibilities of light while helping to meet complex energy and performance requirements. Drawing on the cumulative expertise of coating experts and production teams throughout the world, Guardian continually applies science and cutting-edge technology to the development of new SunGuard products that expand the limits of aesthetics and performance.

• **SNX 62/27**
• SNX 51/23

• SNE 50/25
• SNR 50

• SNR 43
• SNR 35

• SN 68
• SN 54

• Neutral 78/65
• IS 20

Demanding Performance

Whether your commercial glass project is located in a hot, sunny climate, a cold climate or somewhere in-between, Guardian Glass has a product to help meet the environmental demands. From spectrally-selective coatings with high visible light transmission to varying levels of reflectivity, SunGuard Advanced Architectural Glass delivers maximum energy savings that help meet or exceed energy code requirements.

Specifications and Resources

Design professionals in search of [3-part specifications](#), [BIM objects](#) and other design tools like our award-winning [Glass Analytics](#) can find resources on our web site. For direct help, call 1-886-482-7374.

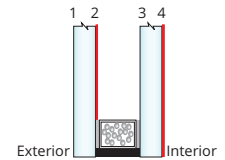

SunGuard – Insulating Glass Data with IS 20(#4)

Product	Substrate Outboard-Inboard	Appearance	Visible Light			UV Transmittance %	SHGC	U-Value	Light to Solar Gain	SHGC	U-Value	Light to Solar Gain	
			Transmittance %	Reflectance Out %	In %								Color Rendering Index
Coating #2 surface with IS 20 #4 surface													
SNX 62/27	Guardian UltraClear® Clear-Clear	Ultra Clear Clear	62	12	13	94.9	8	0.26	0.20	2.43	0.26	0.23	2.41
			60	12	13	92.9	6	0.25	0.20	2.37	0.26	0.23	2.33
SNX 51/23	Guardian UltraClear Clear-Clear	Neutral Blue	51	14	15	94.2	12	0.22	0.20	1.34	0.22	0.23	2.30
		Neutral Blue	49	14	14	91.9	10	0.22	0.20	2.27	0.22	0.23	2.22
SNE 50/25	Guardian UltraClear Clear-Clear	Blue-Silver	48	19	18	91.3	21	0.24	0.20	1.99	0.25	0.23	1.97
		Blue-Silver	47	19	18	88.9	16	0.24	0.20	1.96	0.24	0.23	1.93
SN 68	Guardian UltraClear Clear-Clear	Ultra Clear	69	12	13	97.8	37	0.38	0.20	1.81	0.38	0.24	1.80
		Clear	66	12	13	95.4	29	0.36	0.20	1.83	0.36	0.24	1.82
SN 54	Guardian UltraClear Clear-Clear	Ultra Clear	55	15	21	97.6	20	0.28	0.20	1.98	0.28	0.24	1.96
		Clear	53	15	20	96.2	15	0.27	0.20	1.96	0.27	0.24	1.93
SNR 50	Guardian UltraClear Clear-Clear	Light Silver	48	27	17	93.8	24	0.24	0.20	1.99	0.25	0.24	1.97
		Light Silver	47	26	17	91.3	18	0.24	0.20	1.97	0.24	0.24	1.94
SNR 43	Guardian UltraClear Clear-Clear	Light Silver	43	29	15	93.5	22	0.22	0.20	1.99	0.22	0.23	1.97
		Light Silver	42	28	15	91.1	17	0.21	0.20	1.96	0.22	0.23	1.92
SNR 35	Guardian UltraClear Clear-Clear	Light Silver	33	36	20	92.1	14	0.16	0.20	2.10	0.16	0.24	2.06
		Light Silver	32	35	19	89.7	11	0.16	0.20	2.02	0.16	0.24	1.97

Please see table notes on following page.

www.guardianglass.com

Phone: 1.866.482.7374

©2022 Guardian Glass, LLC
v.1.25.2022-sum

Guardian, SunGuard, SuperNeutral, CrystalGray, CrystalBlue and Guardian UltraClear are trademarks of Guardian Industries Corp.

 **GUARDIAN®
GLASS**
See what's possible™

The products in this publication are sold subject to Guardian's standard terms and conditions of sale and any applicable written warranties. It is the responsibility of the purchaser to confirm that the products are suitable for their intended application in compliance with the applicable laws and regulations. Please contact your local Guardian representative to obtain any applicable handling and fabrication guides and for the most current product information.

Guardian SunGuard® – Insulating Glass Data

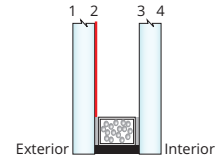

Product	Substrate Outboard-Inboard	Appearance	Visible Light				UV	SHGC	U-Value	Light to Solar Gain	SHGC	U-Value	Light to Solar Gain
			Transmittance %	Reflectance		Color Rendering Index	Transmittance %						
				Out %	In %		Argon			Air			
Coating #2 surface – except Neutral 78/65 on #3 surface													
	Guardian UltraClear®	Ultra Clear	64	11	13	95.0	8	0.26	0.24	2.44	0.27	0.29	2.40
	Clear-Clear	Clear	62	11	12	93.0	6	0.26	0.24	2.36	0.27	0.29	2.31
SNX 62/27	Green-Clear	Green	52	9	12	85.1	3	0.23	0.24	2.25	0.24	0.29	2.13
	CrystalGray-Clear	Light Gray	44	8	11	89.8	3	0.21	0.24	2.08	0.22	0.29	1.98
	Gray-Clear	Gray	31	6	11	90.7	3	0.17	0.24	1.83	0.18	0.29	1.71
	CrystalBlue-Clear	Blue	40	7	11	88.8	4	0.20	0.24	2.01	0.21	0.29	1.91
SNX 51/23	Guardian UltraClear	Neutral Blue	53	14	14	94.2	13	0.23	0.24	2.34	0.23	0.29	2.27
	Clear-Clear	Neutral Blue	51	14	14	91.9	10	0.23	0.24	2.26	0.23	0.29	2.18
	Green-Clear	Blue-Green	43	11	13	84.1	5	0.20	0.24	2.12	0.21	0.29	1.99
	CrystalGray-Clear	Light Gray	36	9	13	88.8	6	0.18	0.24	1.96	0.20	0.29	1.85
	Gray-Clear	Gray	26	7	13	89.8	5	0.15	0.24	1.70	0.16	0.29	1.57
	CrystalBlue-Clear	Blue	33	8	13	87.7	7	0.17	0.24	1.88	0.19	0.29	1.77
SNE 50/25	Guardian UltraClear	Blue-Silver	50	19	18	91.4	22	0.25	0.24	1.99	0.25	0.29	1.96
	Clear-Clear	Blue-Silver	48	19	18	88.9	17	0.25	0.24	1.95	0.25	0.29	1.90
	CrystalGray-Clear	Blue-Gray	34	12	17	86.0	9	0.20	0.24	1.71	0.21	0.29	1.62
	CrystalBlue-Clear	Light Blue	31	11	17	84.7	10	0.19	0.24	1.61	0.20	0.29	1.53
SN 68	Guardian UltraClear	Ultra Clear	71	11	13	97.9	40	0.39	.245	1.82	0.39	0.29	1.80
	Clear-Clear	Clear	68	11	12	95.4	30	0.37	.245	1.82	0.38	0.29	1.80
	Green-Clear	Green	57	9	12	86.9	13	0.29	.245	1.99	0.30	0.29	1.92
	CrystalGray-Clear	Light Gray	48	8	11	92.1	17	0.29	.245	1.69	0.30	0.29	1.64
	Gray-Clear	Gray	34	6	11	93.2	14	0.24	.245	1.43	0.25	0.29	1.37
	CrystalBlue-Clear	Blue	44	7	11	91.1	19	0.28	.245	1.56	0.29	0.29	1.51
SN 54	Guardian UltraClear	Ultra Clear	56	15	21	97.6	21	0.28	0.24	1.98	0.29	0.29	1.95
	Clear-Clear	Clear	54	14	20	96.3	16	0.28	0.24	1.95	0.28	0.29	1.91
	Green-Clear	Green	46	11	19	88.2	7	0.23	0.24	1.99	0.24	0.29	1.89
	CrystalGray-Clear	Light Gray	39	9	19	93.5	9	0.22	0.24	1.75	0.23	0.29	1.67
	Gray-Clear	Gray	27	7	19	94.3	7	0.18	0.24	1.49	0.20	0.29	1.40
	CrystalBlue-Clear	Blue	35	9	19	92.6	10	0.21	0.24	1.64	0.22	0.29	1.57
SNR 50	Guardian UltraClear	Light Silver	50	27	17	93.8	25	0.25	0.24	2.00	0.25	0.29	1.96
	Clear-Clear	Light Silver	48	26	17	91.3	19	0.25	0.24	1.96	0.25	0.29	1.91
	CrystalGray-Clear	Silver Gray	34	15	16	88.2	10	0.20	0.24	1.71	0.21	0.29	1.63
	CrystalBlue-Clear	Silver Blue	31	14	16	86.9	12	0.19	0.24	1.61	0.20	0.29	1.53
SNR 43	Guardian UltraClear	Light Silver	45	28	14	93.5	24	0.22	0.24	1.99	0.23	0.29	1.96
	Clear-Clear	Light Silver	43	28	14	91.1	17	0.22	0.24	1.94	0.23	0.29	1.89
	Green-Clear	Green	36	21	14	83.0	8	0.19	0.24	1.89	0.20	0.29	1.78
	CrystalGray-Clear	Silver Gray	31	16	14	87.9	9	0.18	0.24	1.68	0.19	0.29	1.59
	Gray-Clear	Silver Gray	22	11	13	89.2	8	0.15	0.24	1.41	0.17	0.29	1.31
	CrystalBlue-Clear	Silver Blue	28	14	13	86.7	11	0.18	0.24	1.58	0.19	0.29	1.50
SNR 35	Guardian UltraClear	Light Silver	34	36	20	92.1	15	0.16	0.24	2.09	0.17	0.29	2.03
	Clear-Clear	Light Silver	33	35	19	89.8	11	0.17	0.24	2.00	0.17	0.29	1.92
	Green-Clear	Green	28	26	19	81.9	10	0.15	0.24	1.80	0.17	0.28	1.67
	CrystalGray-Clear	Silver Gray	23	20	19	86.7	6	0.14	0.24	1.63	0.15	0.29	1.51
	CrystalBlue-Clear	Silver Blue	21	17	19	85.7	7	0.14	0.24	1.55	0.15	0.29	1.44
NU 78/65(#3)	Guardian UltraClear	Ultra Clear	81	13	13	99.5	54	0.73	0.27	1.12	0.72	0.31	1.12
	Clear-Clear	Clear	78	13	13	96.9	39	0.66	0.27	1.18	0.66	0.31	1.18

- All insulating glass configurations are 6 mm/12.7 mm spacer/6 mm:
 - Configurations with Guardian UltraClear® low-iron glass contain Guardian UltraClear outboard & inboard.
 - All other insulating glass configurations contain substrates as indicated.
- The performance values shown are nominal and subject to variations due to manufacturing tolerances.
- Guardian performance data are calculated for center-of-glass only in accordance with LBNL Window 7 program.
- SNR 35, SNR 43, SNR 50 and IS 20 require heat-treatment.
- U-value calculated is winter nighttime.
- A slight shift in visible light reflectance or transmission may be noticed after heat-treatment.
- Guardian reserves the right to change product performance characteristics without notice or obligation.





**GUARDIAN®
GLASS**

See what's possible™

SunGuard® eXtraSelective

SNX 62/27

More natural light, less heat gain, greater energy savings

Let natural light do what it does best with SunGuard SNX 62/27 coated glass. SNX 62/27 coated glass product offers the highest light-to-solar-gain ratio of all SunGuard coated glass. This triple silver coating is an excellent option for daylighting—making it easy to create more inviting spaces, increase occupant comfort and help achieve LEED® credits. Its neutral/green appearance stays true to your design vision while helping to gain the energy-saving performance you desire.



Product Information

Substrate	/	/	/
Base Glass/Thickness	/	/	/
Applications	Windows / Skylights / Facades / Curtain walls / Doors		
Manufacturing options	Heat Strengthened / Heat Soaked / Annealed / Tempered / Bent		
Recommended Coating Positions	Double glazed: #2 or #3 surface (restrictions apply) Triple Glazed: #2 surface		
Maximum Size	130"x240"		
Edge Deletion	Yes		
Glass type	Low E		
Glass functions	U-Value Benefit		
Fabrication options	Must be used in an Insulating Glass Units		
Appearance	Clear		



**GUARDIAN[®]
GLASS**

See what's possible™



Double Glazed

Transmittance Visible (τv %)	Visible Light		General Color Rendering Index (Ra)	Ultraviolet Trans UV(τuv %)	Solar Energy			Thermal Properties			Light to Solar Gain (LSG)		
	Reflectance pv % out	pv % in			Transmittance Solar (τe %)	Reflectance pe % out	pe % in	Absorptance Solar (αe %)	Solar Heat Gain Coefficient (SHGC)	Shading Coefficient (sc)		Winter Night (Btu/hr-ft ² -F)	U-Value Summer Day (Btu/hr-ft ² -F)
Double Glazed: 6-12, 7-6 SunGuard® eXtraSelective SNX 62/27 on #2, , 90% Argon Fill													
62	11	12	93.0	6	23	39	42	38	0.26	0.30	0.238	0.209	2.36
Double Glazed: 6-12, 7-6 SunGuard® eXtraSelective SNX 62/27 on Guardian CrystalGray #2, Clear Float, 90% Argon Fill													
44	8	11	89.8	3	16	19	42	64	0.21	0.24	0.238	0.209	2.08
Double Glazed: 6-12, 7-6 SunGuard® eXtraSelective SNX 62/27 on Green #2, Clear Float, 90% Argon Fill													
52	9	12	85.1	3	18	10	42	72	0.23	0.26	0.238	0.209	2.25
Double Glazed: 6-12, 7-6 SunGuard® eXtraSelective SNX 62/27 on Clear Float #2, Clear Float, 90% Argon Fill													
31	6	11	90.7	3	12	19	42	69	0.17	0.19	0.238	0.209	1.83
Double Glazed: 6-12, 7-6 SunGuard® eXtraSelective SNX 62/27 on Gray #2, Clear Float, 90% Argon Fill													
63	11	12	94.0	7	24	51	42	26	0.26	0.30	0.238	0.209	2.41



**GUARDIAN[®]
GLASS**

See what's possible™



Triple Glazed

Visible Light			Ultraviolet		Solar Energy				Thermal Properties			Light to Solar Gain (LSG)	
Transmittance Visible (τv %)	Reflectance		General Color Rendering Index (Ra)	Trans UV(τuv %)	Transmittance Solar (τe %)	Reflectance		Absorptance Solar (αe %)	Solar Heat Gain Coefficient (SHGC)	Shading Coefficient (sc)	U-Value		
	pv % out	pv % in				pe % out	pe % in				Winter Night (Btu/hr-ft ² -F)	Summer Day (Btu/hr-ft ² -F)	
Triple Glazed: 6-12.7-6-12.7-6 SunGuard@eXtraSelective SNX 62/27 on Clear Float #2, Clear Float, 90% Argon Fill													
56	14	18	91.6	5	21	40	35	39	0.24	0.27	0.179	0.173	2.33
Triple Glazed: 6-12.7-6-12.7-6 SunGuard@eXtraSelective SNX 62/27 on Guardian CrystalGray #2, Clear Float, Clear Float, 90% Argon Fill													
40	10	17	88.5	3	15	20	35	66	0.19	0.22	0.179	0.173	2.08
Triple Glazed: 6-12.7-6-12.7-6 SunGuard@eXtraSelective SNX 62/27 on Green #2, Clear Float, Clear Float, 90% Argon Fill													
47	11	18	83.8	2	16	11	35	73	0.21	0.24	0.179	0.173	2.25
Triple Glazed: 6-12.7-6-12.7-6 SunGuard@eXtraSelective SNX 62/27 on Clear Float #2, Clear Float, Clear Float, 90% Argon Fill													
28	7	17	89.4	2	11	19	34	70	0.15	0.17	0.179	0.173	1.84
Triple Glazed: 6-12.7-6-12.7-6 SunGuard@eXtraSelective SNX 62/27 on Gray #2, Clear Float, Clear Float, 90% Argon Fill													
57	15	18	92.7	6	21	52	35	27	0.24	0.27	0.179	0.173	2.37

The performance values shown are nominal and subject to variations due to manufacturing tolerances. Spectra-photometric values according to NFRC2010 / US Standard.

www.guardianglass.com

All trademarks noted are owned by, licensed to or used with permission by Guardian Glass.
©2021 Guardian Glass, LLC

1-855-58-GLASS (452777)
2300 Harmon Road, Auburn Hills, Michigan 48326

Published Date: 01 - May - 2023

The products in this publication are sold subject to Guardian's standard terms and conditions of sale and any applicable written warranties (available at www.guardianglass.com or from your local Guardian representative upon request). It is the responsibility of the purchaser to confirm that the products are suitable for their intended application in compliance with the applicable laws and regulations. Please contact your local Guardian representative to obtain any applicable handling and fabrication guides and for the most current product information.

ALUMINUM PICKET RAILING SYSTEMS



Regular Picket

Wide Picket

- ✔ **Picture Frame**
The same rails and post design creates a consistent frame around your infill of choice (regular picket, wide picket, framed glass, cable).
- ✔ **Ease of Installation**
Factory attached brackets mean a quick and simple assembly.
- ✔ **No Secondary Handrail Required**
Creates a better looking project because VISTA stair railing meets the graspable and continuous requirement.
- ✔ **VISTA Planner Project Software**
Simplifies estimating and installation process.
- ✔ **Safety Assured**
Tested in accordance with national building codes.

AVAILABLE AT:

vistarailings.com

ALUMINUM PICKET RAILING SYSTEMS

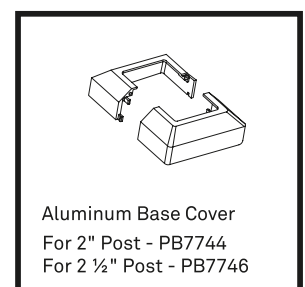
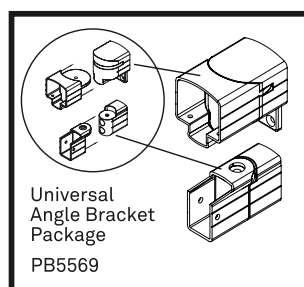
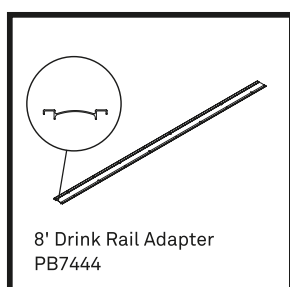
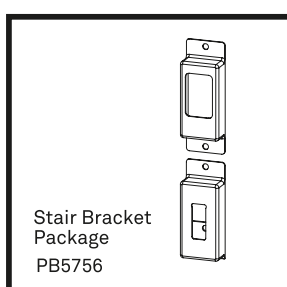
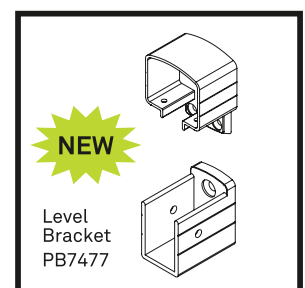
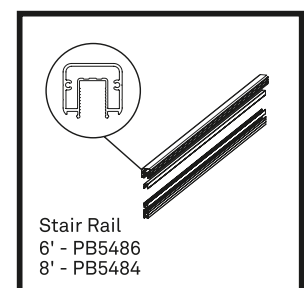
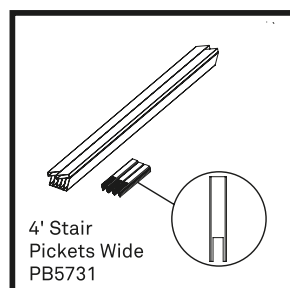
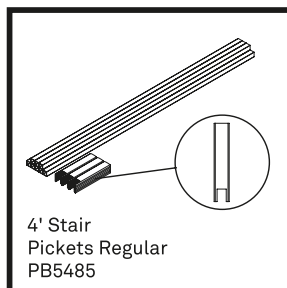
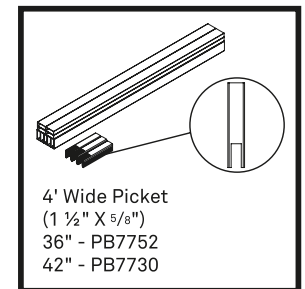
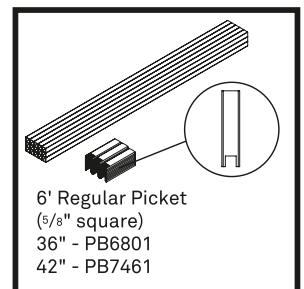
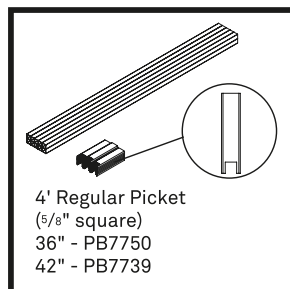
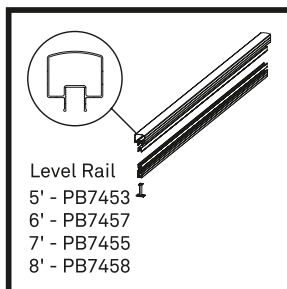
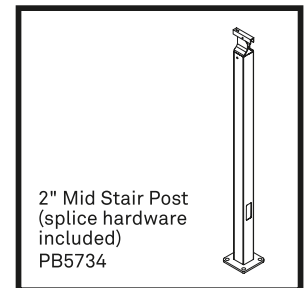
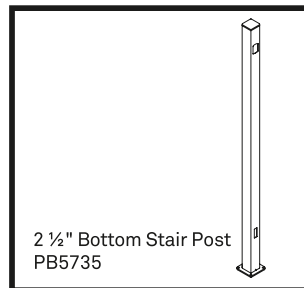
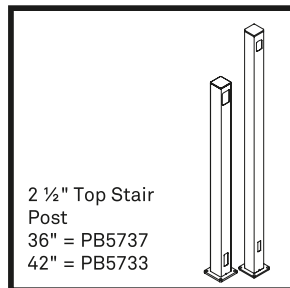
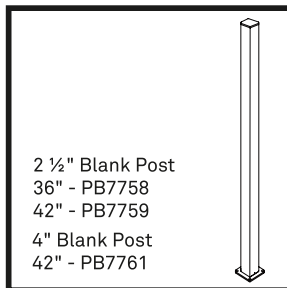
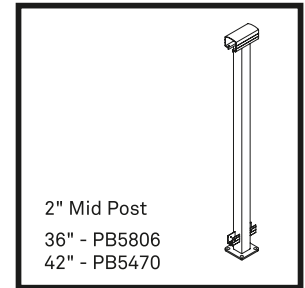
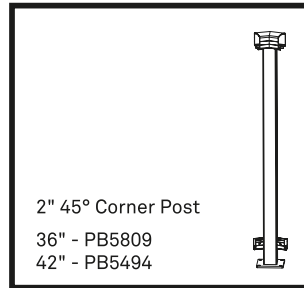
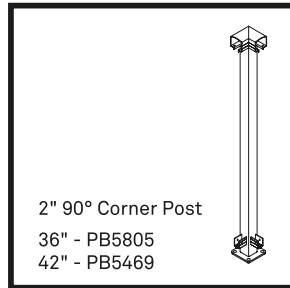
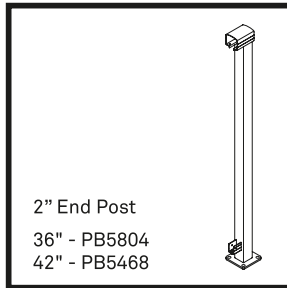

Note: Check with your local building inspection department as local building codes and bylaws may apply prior to installation.

Available Colors:

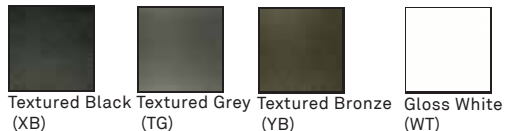



**GUARDIAN®
GLASS**

See what's possible™

Guardian UltraClear®

Guardian UltraClear

Guardian UltraClear® Low-Iron Glass

Guardian UltraClear® low-iron glass can help bring the wow factor to your next architectural project. It's noticeably clearer than standard glass — so what people see is completely up to you. True transparency. Breathtaking views. No distractions.



Product Information

Substrate Base Glass/Thickness	Guardian UltraClear/2.3 mm. (3/32") - 12 mm. (1/2")
Applications	Furniture / Facades / Fittings
Manufacturing options	Heat Strengthened / Heat Soaked / Annealed / Tempered / Laminated
Recommended Coating Positions	N/A
Maximum Size	<130"x240" (3302x6096mm)
Edge Deletion	No
Glass type	Low Iron Content
Appearance	Neutral

A7a

The products in this publication are sold subject to Guardian's standard terms and conditions of sale and any applicable written warranties (available at www.guardianglass.com or from your local Guardian representative upon request). It is the responsibility of the purchaser to confirm that the products are suitable for their intended application in compliance with the applicable laws and regulations. Please contact your local Guardian representative to obtain any applicable handling and fabrication guides and for the most current product information.

CRL Frameless Base Shoe System

- Great for Glass Windbreaks, Pool Enclosures, Perimeter Fencing, Sound Barriers, and Balconies
- Unique Designs That Allow Completely Unobstructed Views
- Designed and Engineered to Meet the Strictest Codes
- Custom Fabrication is Also Available to Meet Your Specifications

CRL Base Shoe Profiles

- Drilled and Counter Bored Base Shoes for Monolithic and Laminated Tempered Glazing
- Typically Used as the Base Channel for Glass Windscreen or Railing Systems
- Six Architectural Finishes Available

CRL Aluminum Base Shoes

- Choices Available for Various Glass Thicknesses



8B Base Shoe Windscreen in Brushed Stainless

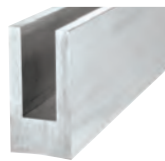

Series W5B
3/8" (10 mm) Monolithic



Series B5A
1/2" (12 mm) Monolithic



Series 8B10
1/2" (12 mm) Monolithic

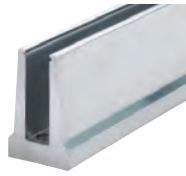

Series B5T
1/2" (12 mm) Monolithic



Series 9BL68
11/16" (15mm) Laminated

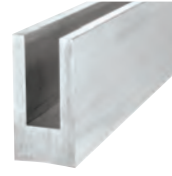

Series W7B
3/4" (19 mm) Monolithic

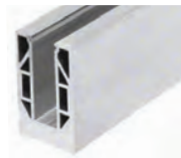

Series 8B34
3/4" (19 mm)
Monolithic

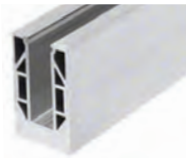

Series 9BL56
9/16" (14.3 mm)
Laminated

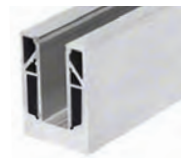

Series 9BL21
27/32" (21.52 mm)
Laminated



Series L25S
1-1/16" (25.52 mm)
Laminated

Aluminum Base Shoes are used as the base channel for glass railing systems and frameless glass windscreen systems. There are ten distinct series to accommodate monolithic tempered and laminated glass in various thicknesses from 3/8" to 1-1/16".

In typical glass pool surrounds monolithic is the glass of choice. But in situations where the glass panels are elevated above pedestrian areas, such as in shopping plazas or on balconies, the use of laminated glass is recommended to prevent broken pieces from falling to lower levels.

Base Shoes support both dry glazed and wet glazed installation methods, CRL offers all of the tools and supplies required to make a safe and successful installation.

Stock Base Shoes are available pre-drilled and counter bored, or in un-drilled lengths that can be custom fabricated to your exact job requirements. Accessory cladding is available in six beautiful architectural finishes, or you can specify custom powder-coated paint in hundreds of colors.

Available Base Shoe Accessories



Base Shoe Cladding



Mitered Corner Cladding



Base Shoe End Caps



Roll In Vinyl

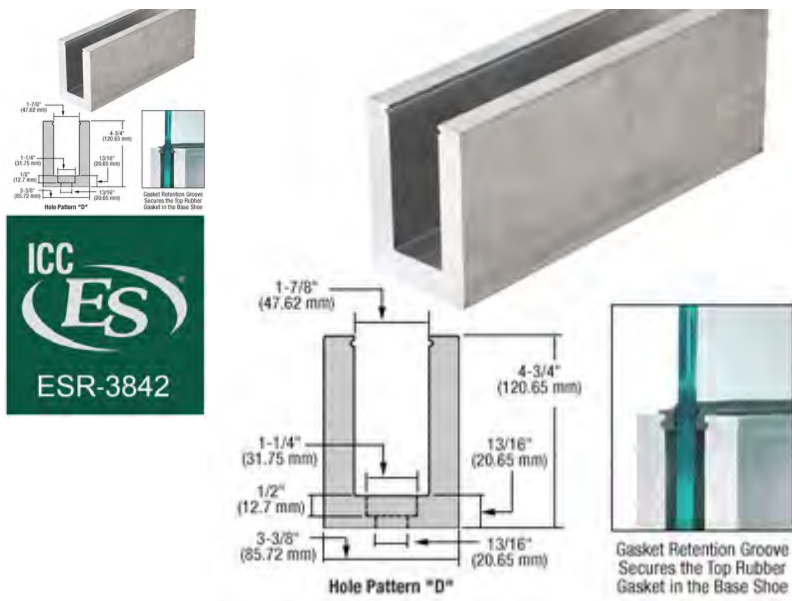

Click Image To Enlarge

Share Print

CRL L25S Series Mill Aluminum 118-1/8" Square Base Shoe Drilled for 1-1/16" Glass

Finish/Color: Mill



Item #: L25S10D

Where to buy

View Technical References, CAD Drawings & Quote Request Forms

Shipping Weight : 102.83 Pounds

Shipping Limitations : No UPS - Common Carrier Only

Compliance and Restrictions

Warning Reproductive Harm - www.p65warnings.ca.gov

Related Products



CRL TAPER-LOC® Taper Sets for 21.52 and 25.52 mm Laminated Tempered Glass

Item # : LTL10X



CRL TAPER-LOC® Extraction Tool

Item # : TLEX1



CRL TAPER-LOC® Installation/Removal Tool Kit for Glass Railing and Windscreen Systems

Item # : TLK12



CRL 1973 Ammoniated Aerosol Glass Cleaner

Item # : 1973

Product Details

Drilling Center To Center (Inches)	11-13/16	Height (Inches)	4-3/4
Finish/Color:	Mill	Length (Inches)	118-1/8
Glazing Thickness (Inches)	1-1/16	Material	Aluminum
Glazing Type	Laminated	Width (Inches)	3-3/8

Product Overview

For 1-1/16" (25.52 mm) Laminated Tempered Glass (12 x 1.52 x 12 mm)

Drilled and Counter Bored 11-13/16" (300 mm) Center-to-Center, or We Will Custom Drill to Your Specifications
Typically Used as the Base Channel for Glass Railing Systems or Windscreens
Works with LTL10X TAPER-LOC® Taper Sets
Engineering Reports Available
CRL Recommends Consulting with the Glass Fabricator Prior to Wet Setting Laminated Tempered Glass
CRL Glass Railing Systems Meets NBC Load Requirements When Installed in Accordance to **ICC-3842**

The **CRL L25S Series Laminated Square Base Shoe** is used as the base channel for glass railing systems. It can be clad in four choices of architectural finishes. The most critical component in a railing system is the proper attachment of the Base Shoe to the substrate. CRL has engineered a variety of attachment methods, and has developed an acceptable combination of drilling patterns and fasteners. A printed brochure with instructions, installation hints, cleaning, and refinishing techniques is available.

GLASS SPECIFICATIONS:

For use with 1-1/16" (25.52 mm) Laminated Tempered Glass 1/2" x .060 x 1/2" (12 mm x 1.52 mm x 12 mm)
Thickness Range: 0.960" to 1.060" (24.40 to 26.92 mm) Will work with ASTM 1" (25.4 mm) Monolithic Tempered Glass Will not accommodate the full ASTM thickness range for 1-1/16" (27 mm) glass

Product Warning:

CRL does not recommend direct powder coating of this base shoe extrusion. Powder coated cladding applied over the base shoe is the recommended method.

All pre-drilled CRL Base Shoes have a +1/8 (3mm) / -1/16 (1.5mm) tolerance between each hole drilled in the base. Before drilling installation holes in the concrete or steel substrate it is recommended that the installer place the base shoe into the planned final position, then mark the position of the holes to be drilled into the substrate.

Most shipping weights are approximate and have not been verified. If the exact weight is needed in order to determine shipping costs, and shipping costs are required in order for you to complete your order, please request this prior to submitting your order by contacting CRL Customer Service. Product images shown are of the actual product or a close representation. Colors can vary depending on your computer's video card and on how your monitor's color is adjusted.

Technical References & CAD Drawings

Brochures & Literature		Quote Request Forms	
Windscreen and Pool Fencing Systems Product Information		GRS Base Shoe Quote Request Form	
		GRS Cap Railing System Quote Request Form	
Specifications		CAD Drawings - pdf	
GRS Taper-Loc System Laminated Glass Base Shoe Specifications		GRS Laminated Taper-Loc 02-08-2016 CAD Drawings.pdf	
		L25S10 Detailed CAD Drawings.pdf	
CAD Drawings - dwg		Engineering & Test Reports	
GRS Laminated Taper-Loc 02-08-2016 CAD Drawings.dwg		ESR-3842 ICC-ES Evaluation Report April 2023	
L25S10 Detailed CAD Drawings.dwg		GRS Glass Railing Systems 25.52 mm 1 inch U.S. Official Test Report 06-22-2010	
		GRS Taper-Loc Dry Glaze System 1-1-16 inch 25.5 mm Laminated Glass Engineering Report 11-08-2021	

HIGH PERFORMANCE LINE

EXTREME[®] 1024 HIGH PERFORMANCE DOOR A8

Models EPD1024 & EPI1024 (insulated)



1 MILLION CYCLES FOR HIGH USE OPENINGS

CONTINUOUS-DUTY DESIGN

The Extreme 1024 High Performance Door delivers reliable security, no maintenance (outside of routine checks) and an exceptional cycle life. It also offers extreme durability backed by a five year warranty.

SPEED YOU CAN COUNT ON

Tested to perform for more than a million cycles at an opening speed of up to 24" per second, 1024 doors operate **three times faster** than standard coiling overhead sectional doors.

PREFERRED APPLICATIONS

This door is a superior choice for high-security needs and high-use applications (distribution, government, manufacturing, parking, transportation, etc.), and accepts virtually all activation systems.

PROVEN RETURN ON INVESTMENT

1024 Doors provide the lowest lifetime cost and lowest cost-per-cycle versus other high-performance slatted products. Plus, their cost-per-cycle savings increase dramatically when compared to standard coiling doors often used incorrectly in high-cycle openings.

ENERGY EFFICIENCY

This door can maximize energy savings by quickly sealing your building during inclement weather to minimize air exchange. The insulated model features the patented Thermiser Max perimeter sealing system – which meets ASHRAE[®] 90.1², 2015 IECC[®] and California's Title 24 air infiltration requirements with an independently tested³ value of less than 0.3 CFM/FT².

800.233.8366 | cornelliron.com

CornellCookson, LLC. is an ISO 9001:2015 registered company
3.2022

EXTREME SERIES

CORNELL
Innovative door solutions[™]

HIGH PERFORMANCE LINE **EXTREME® 1024 HIGH PERFORMANCE DOOR**

Models EPD1024 & EPI1024 (insulated)

STANDARD COMPONENT MATERIALS AND FINISHES

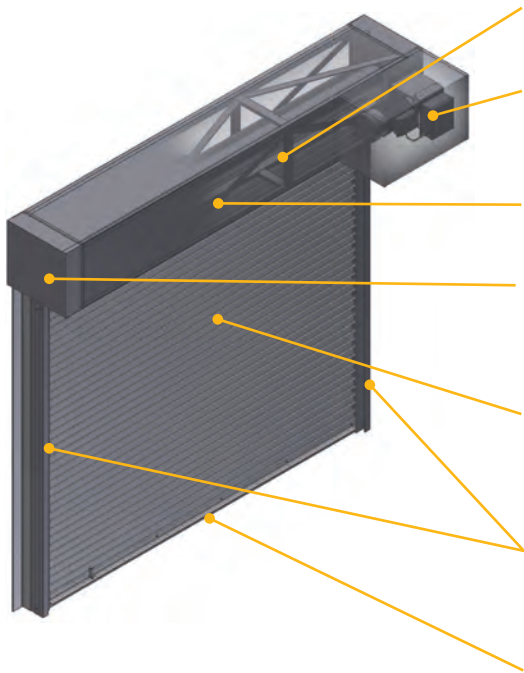

HOOD (optional) - Galvanized steel with powder coat finish to match curtain. Encloses the curtain and provides weather resistance at the head of the door.

MOTOR - UL listed, SEW Eurodrive TEFC NEMA 4 variable-speed motor and patented, high-performance brake prevents curtain from free falling in the unlikely event of operator component failure.

SPRINGLESS SHAFT - Steel. Design reduces maintenance requirements and facilitates cycle capacity.

BRACKETS/COIL BOX ASSEMBLY - Steel plate brackets are part of the unitized coil box assembly with the curtain and barrel. Access hatch for ease of servicing. Drive and tension brackets both furnished with precision ball bearings.

CURTAIN - Galvanized steel with rust inhibiting CycleShield™ powder coat finish in Gray, Tan, or White. Interlocking roll-formed slats with end locks riveted to ends of alternate slats to maintain slat alignment and prevent wear. Model EPI1024 features a foamed in place insulated curtain

GUIDES - Steel angles with powder coat finish to match curtain. Self-lubricating UHMW anti-wear strips greatly reduce friction and curtain wear. Perimeter-sealing, double brush weather strip.

BOTTOM BAR - Two back-to-back structural steel angles with powder coat finish in Gray, Tan or White.

OPERATION AND STRUCTURAL REQUIREMENTS

Motor operation required.

This product is supported by a guide assembly attached to the jamb construction. No additional header supports are mandated by a larger opening width.

- ▶ **Static up to 50 PSF design wind-load**
- ▶ **Operational up to 10 PSF maximum wind-load**

OPTIONAL MATERIALS AND FINISHES

- ▶ Stainless steel - Type 304 in #4 finish
- ▶ SpectraShield® Powder Coating in more than 180 colors
- ▶ Zinc-enriched, corrosion-resistant powder coating in Gray

UNIQUE FEATURES

1024 DRIVE AND CONTROL SYSTEM - Control panel features wall-mounted starter. PLC controller with variable-frequency drive featuring soft-start and soft-stop at both ends of limit travel. NEMA4 rated for harsh weather environments.

MONITORED PROTECTION, EVEN AT HIGH SPEEDS - The factory-mounted UL 325-2010 (NEMA 4C) compliant photo eye sensors allow for momentary contact operation, useful in parking garages and other high-use openings. Interruption of the photo eye beam before the door fully closes causes the door to immediately halt downward travel and reverse direction to return to the open position.

SAFETYGARD LIGHT CURTAIN TECHNOLOGY - The factory-mounted light curtain attaches easily to the guide assembly and extends approximately 6' high from the finished floor on both sides. If the door is cycling and an object passes through the curtain beams, the door will immediately halt downward travel and reverse direction to return to the open position.

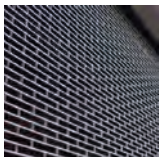

CUSTOM-DESIGNED SOLUTIONS

Contact our experienced Architectural Design Support Team for help in customizing our products to fit your specific application.

 www.architectdoorhelp.com

800.233.8366 | cornelliron.com

CornellCookson, LLC. is an ISO 9001:2015 registered company

3.2022

CORNELL
Innovative door solutions.™

Schüco ASS 50

Aluminium Schiebe- und Hebeschiebesystem
Aluminium sliding and lift-and-slide system

A9a



Schüco Schiebesystem ASS 50
Schüco Sliding System ASS 50

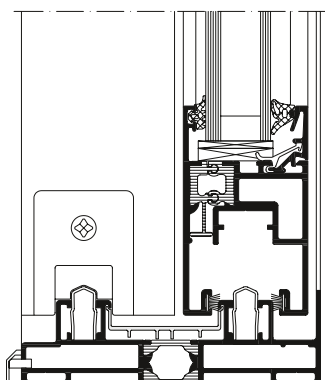

Schüco Schiebesystem ASS 50,
Maßstab 1:3
Schüco Sliding System ASS 50,
scale 1:3

Schüco ASS 50

Produktvorteile

- Schlagregendichtheit bis Klasse 9A nach DIN EN 12208
- Große Typenvielfalt auf Basis 1-, 2-, und 3-spüriger Blendrahmen
- Schalldämmung gemäß DIN EN ISO 140-3 und DIN EN ISO 717-1, $R_w \leq 40$ dB
- Glasstärken von 8-32 mm einsetzbar
- Flaches Blendrahmenprofil als umlaufender Rahmen
- Große Farbvielfalt, außen andersfarbig als innen

Product benefits

- Watertightness up to class 9A in accordance with DIN EN 12208
- Wide choice due to single, double and triple track outer frames
- Sound insulation in accordance with DIN EN ISO 140-3 und DIN EN ISO 717-1, $R_w \leq 40$ dB
- Glazing thickness 8-32 mm
- Flat outer frame profile as continuous frame
- Wide choice of colours – different inside and outside



Verarbeitungsvorteile

- Hohe Flexibilität im Objektgeschäft durch Profil-Eigenverbund
- Kombinierbar mit Oberlichtern, Seitenteilen oder Brüstungsfeldern der Serie Schüco Fenster AWS 50, AWS 60 oder AWS 65

Fabrication benefits

- High degree of flexibility due to customers being able to roll their own profiles together
- Can be combined with toplights, side sections or spandrel panels from the Schüco window series AWS 50, AWS 60 or AWS 65

Technische Daten Technical data

	Wert Value
Wärmedämmung Thermal insulation	U_w ab 1,9 W/(m ² K) U_w from 1,9 W/(m ² K)
Flügelrahmen-Bautiefe Basic depth of vent frame	50 mm
Flügelmaße (BxH) Vent size (WxH)	max. 3.000 x 3.000 mm
Flügelgewicht Vent weight	max. 400 kg
Widerstandsklasse Security class	RC2 (WK2)
Anzahl der Laufschienen Number of tracks	1 – 3

Schüco International KG
www.schueco.com

SCHÜCO

Schüco ADS 75 HD.HI

Aluminium Door System
Aluminium-Türsystem

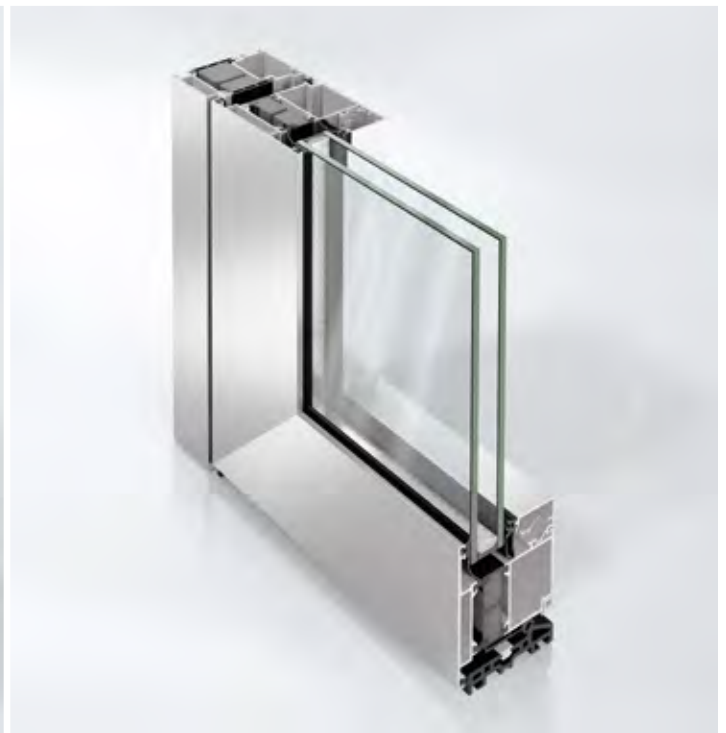

Busy buildings require particularly robust door systems. Their value is enhanced by the specially reinforced construction and the large opening width of the Schüco ADS 75 HD.HI (Heavy Duty, High Insulation) door. Not only is it a striking feature of the façade, it is also suitable for use in almost every type of project with a basic depth of 75 mm and clearance heights of up to 3,000 mm. The degree of creative freedom is particularly high. Suitable for use with all Schüco façade and window systems, the benefits of the classic and timeless design are self-evident.

Hochfrequentierte Gebäude benötigen besonders stabile Türsysteme. Ihr Nutzwert steigt durch die speziell verstärkte Konstruktion und die große Öffnungsweite der Schüco Tür ADS 75 HD.HI (Heavy Duty, High Insulation). Die Tür setzt nicht nur markante Blickpunkte in der Fassade, sondern ist bei einer Bautiefe von 75 mm und Durchgangshöhen von bis zu 3.000 mm für nahezu jeden Einsatzbereich geeignet. Der Freiheitsgrad in der Gestaltung ist besonders groß. Passend zu allen Schüco Fassaden- und Fenstersystemen zeigen sich die Vorteile des klassischen und zeitlosen Designs.

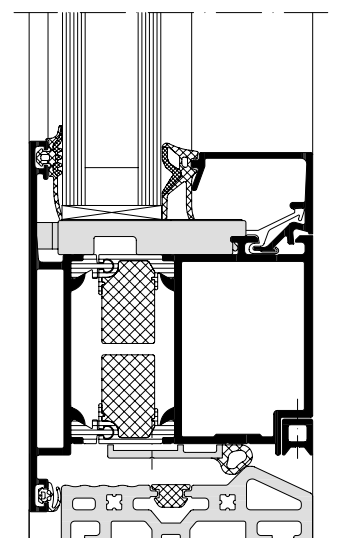

Schüco door system ADS 75 HD.HI,
Sill, scale 1:2
Schüco Türsystem ADS 75 HD.HI,
Fußpunkt, Maßstab 1:2

Schüco Tür ADS 75 HD.HI

Aluminium Door System

Aluminium-Türsystem



Schüco Aluminium door system
ADS 75 HD.HI
Schüco Aluminium-Türsystem
ADS 75 HD.HI



Schüco door system ADS 75 HD.HI
Schüco Türsystem ADS 75 HD.HI

Schüco ADS 75 HD.HI

Product benefits

- Burglar-resistant up to RC3 (WK3)
- Opening width up to 2,800 mm (double-leaf)
- Generous clearance heights of up to 3,000 mm
- Max. leaf weight 200 kg
- Barrel hinge with reinforced design
- Choice of sill rail profile or continuous leaf profile

Produktvorteile

- Einbruchhemmend bis RC3 (WK3)
- Öffnungsweite bis 2.800 mm (2-flügelig)
- Komfortable Durchgangshöhen bis 3.000 mm
- Max. Flügelgewicht 200 kg
- Rollentürband in verstärkter Ausführung
- Wahlweise Sockel- oder umlaufendes Flügelprofil

Fabrication benefits

- Automatic door seal
- Easy-access solutions
- Concealed hinges
- Leaf-enclosing infill
- Door hinges tested in 1,000,000 cycles for continuous loading in accordance with DIN EN 12400
- Emergency fittings
- Emergency exit switch
- Double-leaf full panic door in RC2 (WK2) with Schüco InterLock automatic locking

Verarbeitungsvorteile

- Automatische Türabdichtung
- Barrierefreie Lösungen
- Verdeckt liegende Bänder
- Flügelüberdeckende Füllung
- Türbänder mit 1.000.000 Zyklen auf Dauerbelastung geprüft nach DIN EN 12400
- Panikbeschläge
- Fluchttürsicherung
- 2-flügelige Vollpaniktür in RC2 (WK2) mit Automatikverriegelung Schüco InterLock

Technical data Technische Daten

Test Prüfung	Standard Norm	Value Wert
Thermal insulation Wärmedämmung	DIN EN ISO 1077-2	Value U _f -Wert in W/(m ² K) maximally maximal 2,0
Burglar resistance Einbruchhemmung	DIN EN 1627	RC3 (WK3)
Air permeability Luftdurchlässigkeit	DIN EN 12207	Class Klasse 2
Watertightness Schlagregendichtheit	DIN EN 12208	to Class bis Klasse 5A
Wind resistance Windlastwiderstand	DIN EN 12210 ¹	to Class bis Klasse C3
Mechanical loading Mechanische Beanspruchung	DIN EN 13115	to Class bis Klasse 3

¹ The amount of deflection will depend on the profile Durchbiegungsverhalten profilabhängig.

SCHÜCO

Distributor Australia

CAPRAL

ALUMINIUM

Contact details:

Phone: 1800 ALUMINIUM 258 646

www.capral.com.au

www.schueco.com.au



A10a

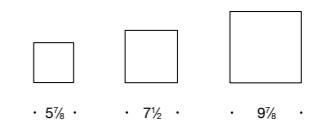

Recessed wall luminaires Asymmetric light distribution

For decades, BEGA has set the standard for recessed wall luminaires worldwide. Newly redesigned with a refined look, broader range of delivered lumens, and contractor friendly enhancements for ease of installation and quality assurance, BEGA's unwavering commitment to quality above all permeates everything about this new approach to recessed wall luminaires.

Recessed wall luminaires with asymmetrical directed light distribution available in multiple sizes. The asymmetrical distribution provides light in a forward orientation and is suitable for lighting ground surfaces, building entrances, and stairways. Separate installation housing allows for seamless coordination into construction and easy maintenance.

Die-cast aluminum housing with die-cast aluminum faceplate · Composite installation housing
Safety glass with optical texture

LED color temperatures: 2700K, 3000K, 3500K, 4000K

BEGA luminaires offer a minimum service life of 60,000 hours, with suitable LED replacement modules guaranteed for up to 20 years after date of purchase. Further LED technical data including luminous flux, CRI, dimming and electrical characteristics are provided on the individual luminaire specification sheets, available at www.bega-us.com

All BEGA standard finishes are matte, textured powder coat with minimum 3 mil thickness. BEGA Unidure® finish, a fluoropolymer technology, provides superior fade protection in Black, Bronze, and Silver. BEGA standard White, as well as optionally available RAL and custom colors, are a polyester powder.

NRTL listed to North American standards · Suitable for wet locations · Protection class IP 65

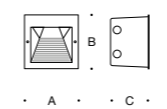

Asymmetric				
	LED	A	B	C
24 210	2.9 W	5 7/8	5 7/8	5 1/4
24 211	4.8 W	7 1/2	7 1/2	5 1/4
24 212	11.6 W	9 7/8	9 7/8	5 1/4



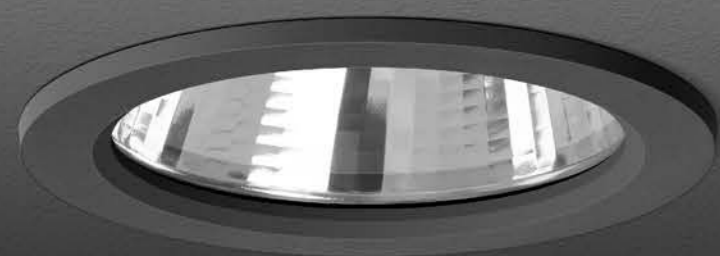

A10b

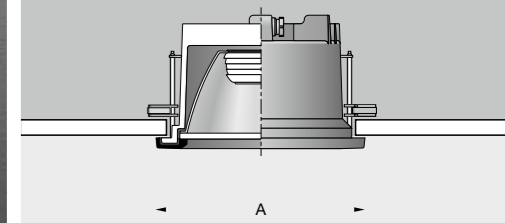

Downlights
Symmetric light distribution

Electronic driver location	ceiling pan
Delivered lumens	1200 · 5015 lm
Luminaire size	Ø 5 ¼ · 6 ¾ · 8 ½
Glass	clear safety glass

Downlights
with symmetric light distribution

A series of compact downlights featuring BEGA Hybrid Optics®, available in a variety of light distributions and light outputs. These luminaires are designed for down lighting atriums, canopies, passages and other interior and exterior locations.

Die-cast aluminum housing and trim ring · Clear safety glass
Reflector surface made of pure anodized aluminum
Molded silicone optical lens · BEGA Hybrid Optics®

LED color temperatures: 2700K, 3000K, 3500K, 4000K

BEGA luminaires offer a minimum service life of 60,000 hours, with suitable LED replacement modules guaranteed for up to 20 years after date of purchase. Further LED technical data including luminous flux, CRI, dimming and electrical characteristics are provided on the individual luminaire specification sheets, available at www.bega-us.com

All BEGA standard finishes are matte, textured powder coat with minimum 3 mil thickness. BEGA Unidure® finish, a fluoropolymer technology, provides superior fade protection in Black, Bronze, and Silver. BEGA standard White, as well as optionally available RAL and custom colors, are a polyester powder.

NRTL listed to North American standards · Suitable for wet locations
Protection class IP 65

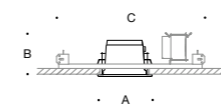

Downlights · narrow beam

	LED	β	A	B	C
24 817	8.3 W	21°	5 ¼	5	18
24 820	16.8 W	21°	5 ¼	5	18
24 818	11.5 W	15°	6 ¾	5	18
24 821	24.5 W	15°	6 ¾	5	18
24 819	17.3 W	19°	8 ½	5	18
24 822	36.0 W	19°	8 ½	5	18

Downlights · wide beam

	LED	β	A	B	C
24 823	8.3 W	38°	5 ¼	5	18
24 826	16.8 W	38°	5 ¼	5	18
24 824	11.5 W	29°	6 ¾	5	18
24 827	24.5 W	30°	6 ¾	5	18
24 825	17.3 W	31°	8 ½	5	18
24 828	36.0 W	32°	8 ½	5	18

Downlights · very wide beam

	LED	β	A	B	C
24 829	8.3 W	59°	5 ¼	5	18
24 832	16.8 W	61°	5 ¼	5	18
24 830	11.5 W	56°	6 ¾	5	18
24 833	24.5 W	57°	6 ¾	5	18
24 831	17.3 W	56°	8 ½	5	18
24 834	36.0 W	56°	8 ½	5	18

β = Beam angle

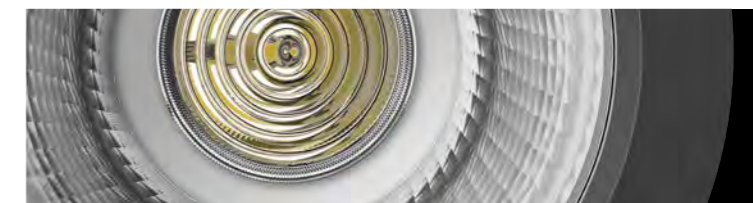



L1

PINE HALL BRICK

BUILD YOUR DREAMS.

2701 Shorefair Drive, Winston-Salem, NC 27105 | pinehallbrick.com | 1-800-334-8689

Product Features & Specifications

Square-Edge Series Product Features & Colors

Features: square edge brick pavers available in 4"X 8" and Modular Size

Colors: 4x8" available in Red, Full Range, Beale St., Autumn, Cocoa, Rose, Dark Accent, Buff, Grey and Ironspot from Madison, NC Plant. Modular available in Red, Full Range and Cocoa from Madison, NC Plant.

Square-Edge Series 2.25" Product Specifications

Unit clay paver shall conform to the requirements of ASTM C902, Class SX, Type 1, Application PX and C67 for Freeze and Thaw. Units shall be standard 4" x 8" (or standard modular) size having dimensions of 2 1/4" x 4" x 8" (or 2 1/4" x 3 5/8" x 7 5/8"), square-edge on both sides, 8,000 psi minimum compressive strength and below 8% cold water absorption. Paver shall conform to Pathway [color] as manufactured by Pine Hall Brick Co., Inc., Winston-Salem, North Carolina and distributed by [party responsible for specification].

Square-Edge Heavy Vehicular 2.75" Product Specifications

Unit clay paver shall conform to the requirements of ASTM C1272, Application PA and C67 for Freeze and Thaw. Units shall be standard 4" x 8" size having dimensions of 2 3/4" x 4" x 8", 10,000 psi minimum compressive strength, minimum breaking load of 475 lb/in and below 6% cold water absorption. Paver shall conform to Pathway Series as manufactured by Pine Hall Brick Co., Inc., Winston-Salem, North Carolina and distributed by [party responsible for specification]. *(Note: Designer needs to emphasize proper paver spacing of 1/16" min to 3/16" max in written specs when specifying this paver in a heavy vehicular paving application. Expect chippage regardless.)*

Jan 2021

STONE LOOK

SKY



Available size



24" x 24"
± 0.8"

Color shading



V2

DESERT



Available size



24" x 24"
± 0.8"

Color shading



V2

ABSOLUTE



Available size



24" x 24"
± 0.8"

Color shading



V2



COSMOS

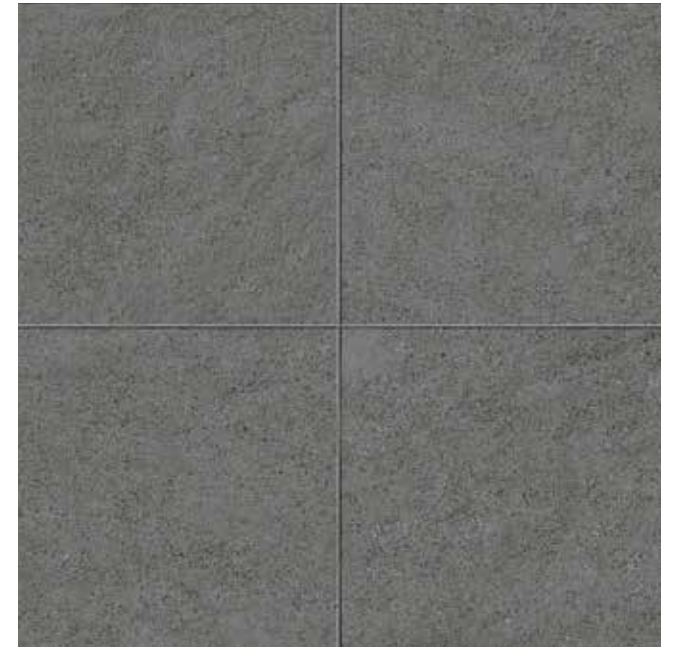

Available size



24" x 24"
± 0.8"

Color shading



V2



The color of pavers printed in this catalog may differ from actual pavers. Paver color reproductions in this catalog are representative only. Slight tone and shade variations are inherent in porcelain pavers. Before selecting a color, we recommend that you contact your local representative, who will provide you with a sample piece of the requested paver.

This porcelain paver product is manufactured with a V2 shade variation. Remember that the amount of color as well as the texture of each piece may vary from paver to paver. Inspect the product immediately upon delivery and select pavers from many boxes during installation to minimize and blend any possible color difference.

Color Shading

