

**FRAME TOP**

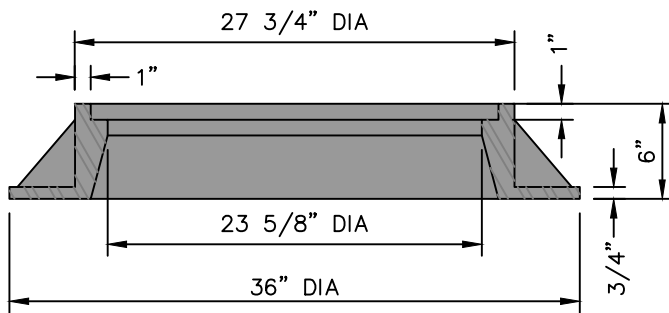

**COVER FACE**



**FRAME SECTION A-A**

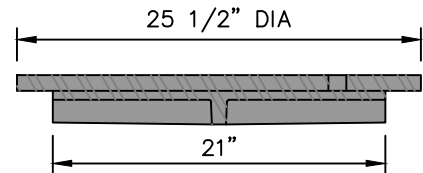

**COVER SECTION B-B**

SPECIFICATIONS	APPROVED MODELS	
	EAST JORDAN IRON WORKS, INC. 1930	CAPITOL FOUNDRY MH-210-CR
COVER WEIGHT	TOTAL	160 Lbs.
FRAME WEIGHT	477 Lbs.	275 Lbs.
LOAD RATING	HEAVY DUTY	HEAVY DUTY
MATERIAL	ASTM A 48 CLASS 35B	ASTM A 48 CLASS 35B
FINISH	UNCOATED	UNCOATED

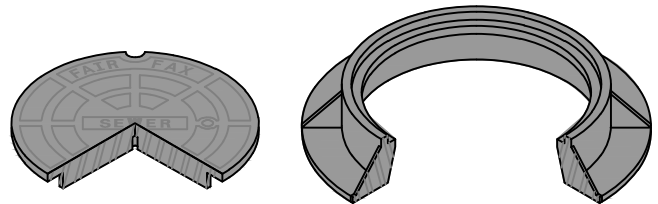

**ISOMETRICS**

**NOTES:**

1. Manhole frames and covers shall be roadway type with deep socket Covers. Machine frames and covers to prevent rattling. Castings shall be gray iron meeting requirements of ASTM A48, class 35B.



Department of Public Works  
10455 Armstrong Street  
Fairfax, VA 22030-3630

**CITY of FAIRFAX**  
USE WITH THE FAIRFAX STANDARD SPECIFICATIONS ONLY

Voice (703) 385-7810  
FAX (703) 591-5727  
www.fairfaxva.gov

**STANDARD SEWER MANHOLE  
FRAME and COVER**

SCALE:  
Not To Scale

DETAIL #  
4.09

REVISION DATE:  
February 2017

SHEET #:  
1 of 1