

FRAME TOP

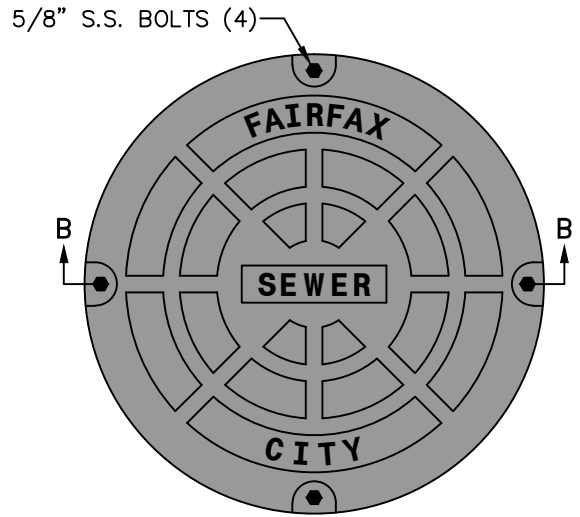

COVER FACE

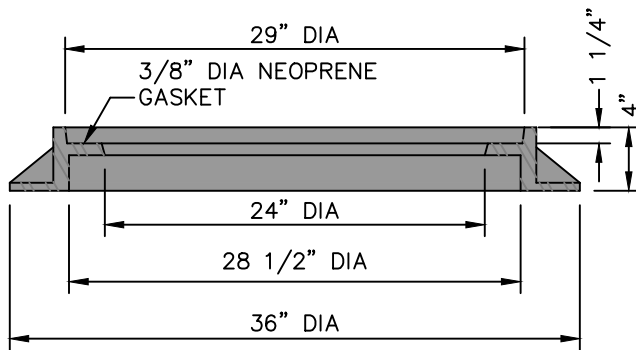

FRAME SECTION A-A

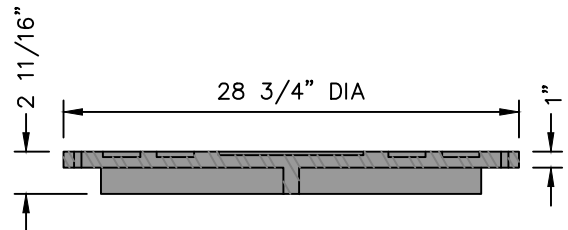

COVER SECTION B-B

SPECIFICATIONS	APPROVED MODELS	
	EAST JORDAN IRON WORKS, INC. 1940	CAPITOL FOUNDRY MH-214-CR
COVER WEIGHT	TOTAL	165 Lbs.
FRAME WEIGHT	384 Lbs.	285 Lbs.
LOAD RATING	HEAVY DUTY	
MATERIAL	ASTM A 48 CLASS 35B	
FINISH	UNCOATED	

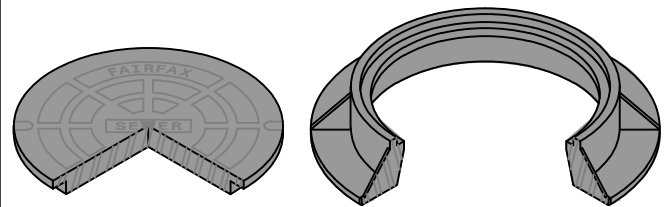

ISOMETRICS

NOTES:

1. Manhole frames and covers shall be roadway type with deep socket covers. Machine frames and covers to prevent rattling. Castings shall be gray iron meeting requirements of ASTM A48, class 35B.



Department of Public Works
10455 Armstrong Street
Fairfax, VA 22030-3630

CITY of FAIRFAX
USE WITH THE FAIRFAX STANDARD SPECIFICATIONS ONLY

Voice (703) 385-7810
FAX (703) 591-5727
www.fairfaxva.gov

**STANDARD SEWER WATER-TIGHT
MANHOLE FRAME and COVER**

SCALE:
Not To Scale

DETAIL #
4.11

REVISION DATE:
February 2017

SHEET #:
1 of 1